



# **ECODENSE BOILER INSTALLATION, OPERATION AND MAINTENANCE INSTRUCTIONS**



**ECODENSE BOILER 500L**  
**ECODENSE BOILER 800L**  
**ECODENSE BOILER 1000L**  
**ECODENSE BOILER 1500L**  
**ECODENSE BOILER 2000L**  
**ECODENSE BOILER 2500L**  
**ECODENSE BOILER 3000L**

**DEAR CUSTOMER,**

ECODENSE BOILER 500L, ECODENSE BOILER 800L, ECODENSE BOILER 1000L, ECODENSE BOILER 1500L, ECODENSE BOILER 2000L, ECODENSE BOILER 2500L, and ECODENSE BOILER 3000L products are designed and manufactured in accordance with the latest technological innovations and safety standards. In this context, ease of use has also been carefully considered.

In order to ensure the device is used with maximum safety, efficiency, and environmental awareness, we strongly recommend that you follow the safety instructions and the user manual.

If you encounter any issue that is not explained in this manual or is unclear, please contact our after-sales service department.

Thank you for choosing the ECODENSE brand.





This user manual is an integral part of the device. It should be kept in a plastic folder and hung in a visible location near the device.

## TABLE OF CONTENTS

1.	WARNINGS.....	3
1.1.	Warning Symbols and Descriptions.....	3
1.2.	General Safety Rules.....	4
2.	WARRANTY CONDITIONS.....	5
2.1.	Conditions Excluded from the Scope of Warranty .....	5
3.	GENERAL FEATURES OF BOILER PRODUCTS .....	6
4.	DIMENSION TABLE .....	8
5.	TECHNICAL DATA.....	16
6.	CLOSED SYSTEM CIRCUIT COMPONENTS .....	20
6.1.	Expansion Tank.....	20
6.2.	Pressure Gauge.....	20
6.3.	Dirt Separator.....	20
6.4.	Air Separator .....	20
6.5.	Check Valve.....	20
6.6.	Pump .....	20
6.7.	Thermometer.....	20
6.8.	Pressure Reducing Valve .....	20
7.	CIRCUIT DIAGRAMS .....	22
8.	EQUIPMENT PLACEMENT AND INSTALLATION REQUIREMENTS.....	26
9.	COMMISSIONING.....	27
10.	EXPANSION TANK APPLICATION.....	27
11.	ECODENSE BOILER PRE-COMMISSIONING CHECK INSTRUCTIONS.....	28
12.	MAINTENANCE .....	29
13.	THINGS TO DO BEFORE CALLING THE AUTHORIZED SERVICE.....	30
14.	AFTER-SALES SERVICES.....	31
15.	NOTES.....	33

## 1. WARNINGS

### 1.1. Warning Symbols and Descriptions

Symbols	Symbol Meanings
	<p>Important information or useful tips related to use</p>
	<p>Warning against hazardous situations that may pose a risk to life and property</p>
	<p>Warning against electrical voltage</p>
	<p>Product handling information</p>
	<p>Keep upright. Fragile. Protect from water.</p>

## 1.2. General Safety Rules

- Installation, disassembly, commissioning, operation, inspection, maintenance, and repair must only be carried out by trained and authorized personnel who have read and fully understood this manual.
- No modifications that may compromise the safety of the device shall be made by individuals and/or organizations.
- All maintenance, commissioning, and installation work must be performed with the device turned off and the power supply disconnected. Failure to comply with these rules may result in electric shock, accidents caused by hot water, and consequently severe injuries or even death.
- Repairs related to safety components must only be performed by the manufacturer.
- The device must never be used by persons with mental disabilities, children, or individuals lacking experience and knowledge.
- Children must be supervised to ensure they do not play with the device.
- Flammable and explosive materials must not be kept near the device.

## 2. WARRANTY CONDITIONS

ECODENSE BOILER 500L, ECODENSE BOILER 800L, ECODENSE BOILER 1000L, ECODENSE BOILER 1500L, ECODENSE BOILER 2000L, ECODENSE BOILER 2500L, ECODENSE BOILER 3000L, and single and double coil boiler products, including the main and auxiliary materials used, are under the warranty of **TERMO ISI SİSTEMLERİ A.Ş.** for a period of **2 (two) years** from the date of commissioning, under the maintenance, adjustment, and operating conditions specified by us, and under the relevant mechanical, chemical, and thermal effects.



This warranty condition is valid only if the device(s) are commissioned and maintained by our authorized service centers.



Our company reserves the right to make changes to the product and all related instructions for the purpose of improvement.

### 2.1. Conditions Excluded from the Scope of Warranty

- Malfunctions arising from failure to fulfill the customer responsibilities specified in the installation, commissioning, operation, and maintenance instructions,
- Malfunctions occurring if commissioning, repair, or maintenance is carried out by unauthorized service personnel,
- Damage to the product during transportation and storage,
- Failure to keep the product in its original packaging until the installation stage,
- Errors arising from incorrect equipment selection,
- Devices damaged due to natural disasters,
- Devices for which the warranty certificate is not presented,
- Devices whose warranty certificate does not bear the stamp and signature of an authorized dealer or service company,
- Devices with tampered warranty certificates or without an original serial number on the product are not covered by the warranty.
- The risks during transportation of the device under the customer's responsibility belong to the customer.
- In case of malfunctions, whether there is user error is determined by a report issued by authorized service stations; if no authorized service station is available, by our authorized dealer, distributor, representative office, or factory.
- Consumers may apply to the relevant Consumer Arbitration Committee with a request for expert examination regarding this report.

### **3. GENERAL FEATURES OF BOILER PRODUCTS**

- High efficiency with 80 mm insulation thickness made of soft polyurethane (foam) with a density of 18 kg/m<sup>3</sup>,
- Titanium-enhanced enamel with WRAS (drinking water approved) certification,
- Fast and high performance thanks to increased coil surface area in the boiler tank,
- Easy and hygienic maintenance advantage with a cleaning flange integrated into the tank
- Integrated design with thermometer,
- Continuous hot water supply with optional electric heater,
- Cathodic protection with magnesium anode rod,
- 7 different large capacity options: 500, 800, 1000, 1500, 2000, 2500, and 3000 liters,
- Suitable for use with heating systems such as condensing boilers, conventional burners, and heat pumps,
- Suitable for use in any environment thanks to its compact design,
- Operating temperature up to a maximum of 95°C,
- 10 bar operating pressure / 13 bar test pressure.

ECODENSE boiler products are available in single-coil models with capacities of 500 / 800 / 1000 / 1500 / 2000 / 2500 / 3000 liters, and double-coil models with capacities of 500 / 800 / 1000 / 1500 / 2000 / 2500 / 3000 liters. The device is manufactured in compliance with TS EN 12897 and TS 736 standards.

The inner surface of the device is enamel-coated in accordance with TS EN 12499 standards, and full protection against corrosion is ensured by means of the anode installed in the device. Since enamel coating means that the internal surfaces are lined with glass, it also provides a high level of hygiene. Depending on the model of the device, there are two thermowells available to which a thermostat sensing element can be connected in order to control the temperature of the water inside the boiler.

The thermal insulation of the boiler's outer shell is provided by 80 mm thick high-density polyurethane. This environmentally friendly polyurethane offers excellent insulation, does not contain HCFC, and does not harm the ozone layer.

In addition, the outer surface of the boiler, as well as its top and bottom covers, are made of ABS (Acrylonitrile Butadiene Styrene) material. Besides providing an aesthetic appearance, ABS material eliminates corrosion and rust issues in humid environments.

Thanks to the thermometer located on the control panel of the boiler, the temperature of the water inside the tank can be easily monitored by the user.

In models equipped with an electric heater, the system is designed to maintain a constant water temperature inside the tank with a thermostat adjustable between 30°C and 65°C, and safety against overheating is ensured by a 95°C safety thermostat.

The outer surface of the boiler is covered with polyurethane insulation with a density of  $42 \pm 2$  kg/m<sup>3</sup> in order to minimize heat losses.

For single and double coil models ranging from 800 liters to 3000 liters, removable foam insulation is used. As the capacity increases, the dimensions of the boiler products also increase; therefore, removable foam insulation is the most ideal solution to prevent difficulties during transportation and when passing through narrow doorways at the installation site. The insulation complies with the EN 15332 Energy Efficiency Standard;

500 L: 42 kg/m<sup>3</sup> water-based rigid PU (HCFC-free) foam (Standard)

800 L – 3000 L: 18 kg/m<sup>3</sup> soft PU (Standard)

Outer casing coating:

500 L: Electrostatic powder-coated steel sheet (Standard)

800 L – 3000 L: Vinlex synthetic leather

Cathodic Protection Element: Magnesium anode in accordance with DIN 4753-3 standard values (Standard)

#### 4. DIMENSION TABLE

##### a. Single Coil Boiler Dimension Table

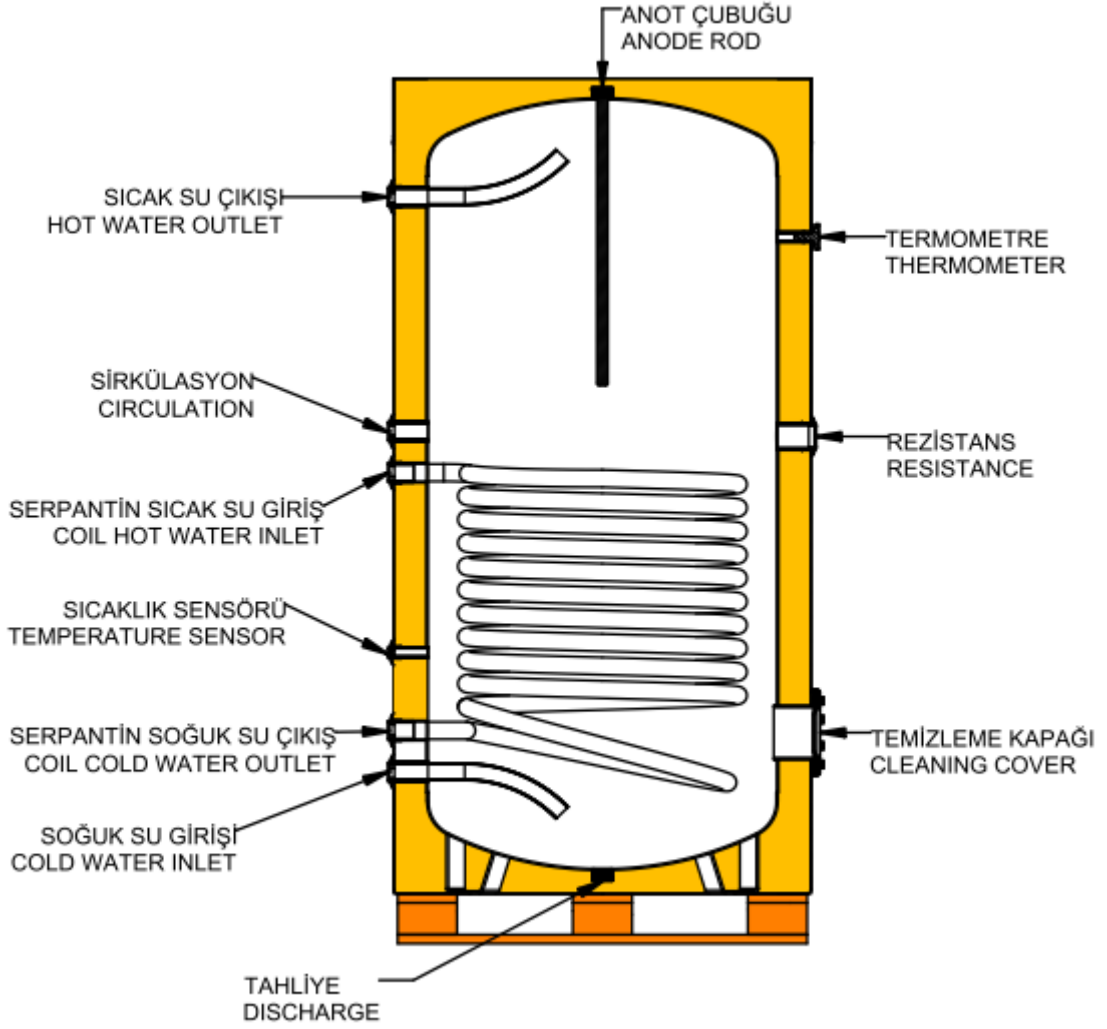

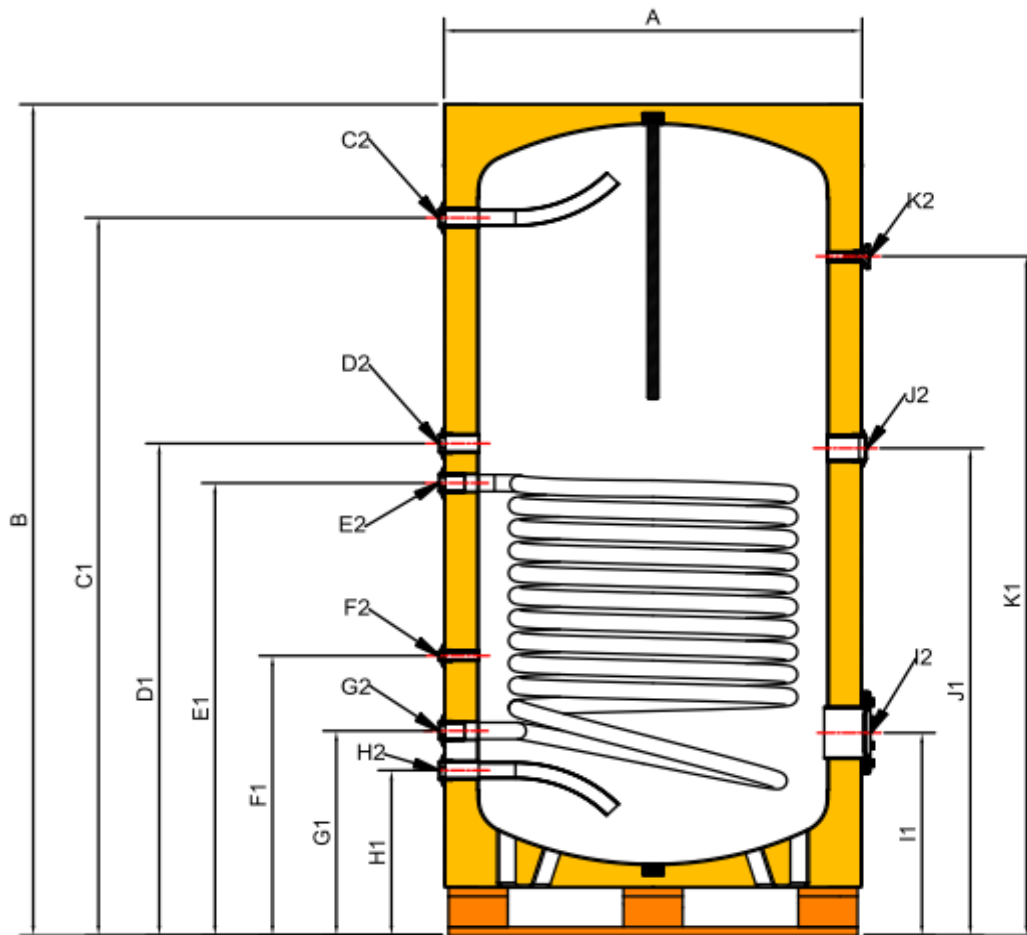

SINGLE COIL BOILER SIZE TABLE

DIMENSION	DESCRIPTION		CAPACITY						
			500	800	1000	1500	2000	2500	3000
A	BOILER DIAMETER (INCLUDING INSULATION)	mm	800	1010	1010	1120	1260	1360	1440
B	HEIGHT	mm	1750	1810	2120	2532	2542	2666	2781
C1	HOT WATER OUTLET HEIGHT	mm	1490	1522	1835	2208	2210	2315	2415
C2	HOT WATER OUTLET DIAMETER	inc	1"	1 1/4"	1 1/4"	1 1/4"	1 1/4"	1 1/4"	1 1/4"
D1	CIRCULATION HEIGHT	mm	845	1093	1264	1414	1364	1555	1570
D2	CIRCULATION DIAMETER	inc	1 1/4"	1 1/4"	1 1/4"	1 1/4"	1 1/4"	1 1/4"	1 1/4"
E1	COIL HOT WATER INLET HEIGHT	mm	1018	993	1164	1314	1264	1455	1470
E2	COIL HOT WATER INLET DIAMETER	inc	1 1/4"	1 1/4"	1 1/4"	1 1/4"	1 1/4"	1 1/4"	1 1/4"
F1	TEMPERATURE SENSOR HEIGHT	mm	695	727	727	763	770	790	805
F2	TEMPERATURE SENSOR DIAMETER	inc	1/2"	1/2"	1/2"	1/2"	1/2"	1/2"	1/2"
G1	COIL COLD WATER OUTLET HEIGHT	mm	505	537	537	573	580	600	615
G2	COIL COLD WATER OUTLET DIAMETER	inc	1 1/4"	1 1/4"	1 1/4"	1 1/4"	1 1/4"	1 1/4"	1 1/4"
H1	COLD WATER INLET HEIGHT	mm	405	437	437	473	480	500	515
H2	COLD WATER INLET DIAMETER	inc	1"	1 1/4"	1 1/4"	1 1/4"	1 1/4"	1 1/4"	1 1/4"
I1	CLEANING COVER	mm	505	533	532	568	575	595	610
I2	CLEANING COVER DIAMETER		DN125	DN125	DN125	DN125	DN125	DN125	DN125
J1	HEATING ELEMENT HEIGHT	mm	1100	1093	1252	1414	1365	1555	1570
J2	HEATING ELEMENT DIAMETER	inc	1 1/4"	2"	2"	2"	2"	2"	2"
K1	THERMOMETER HEIGHT	mm	1390	1367	1737	2026	2023	2100	2158
K2	THERMOMETER DIAMETER	inc	1/2"	1/2"	1/2"	1/2"	1/2"	1/2"	1/2"

b. Double Coil Boiler Dimension Table

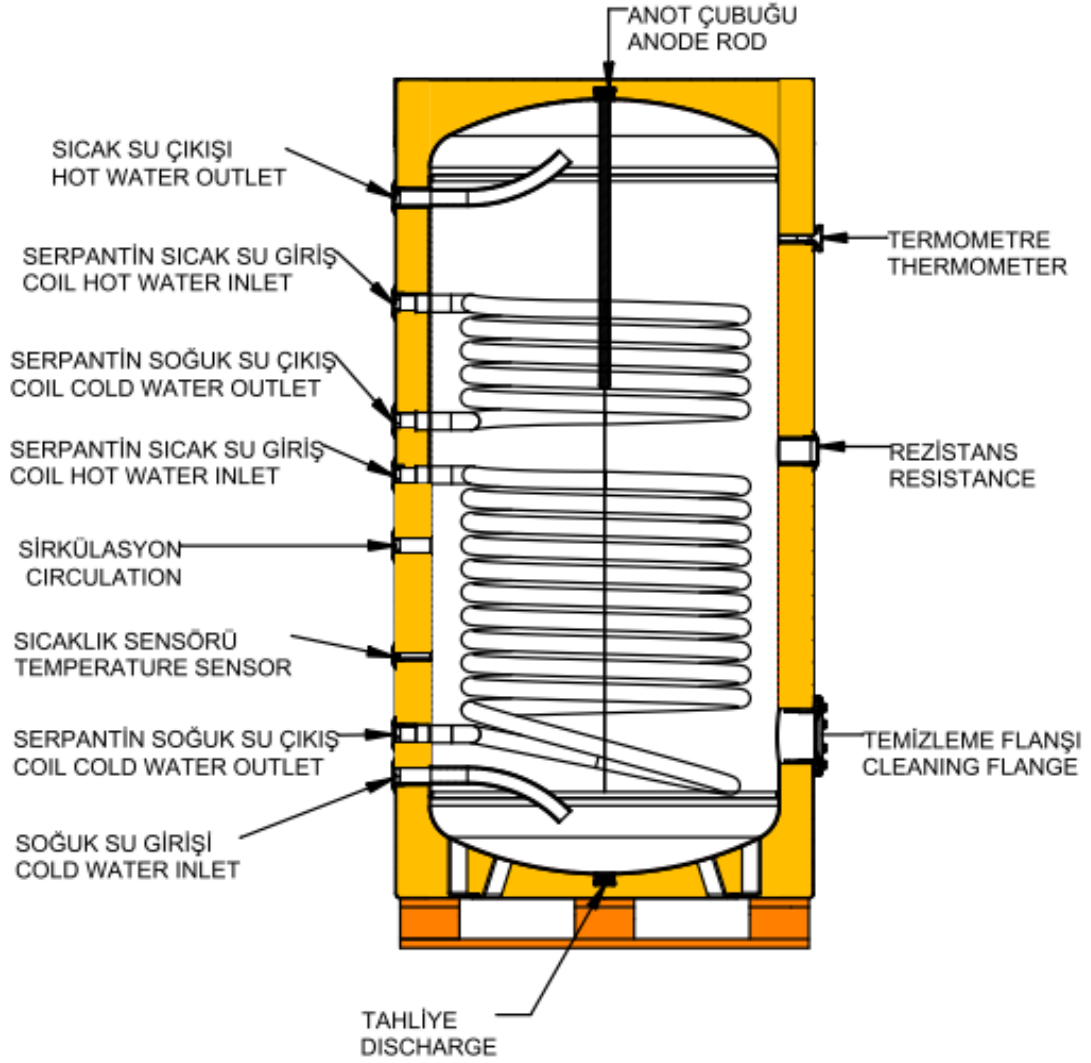

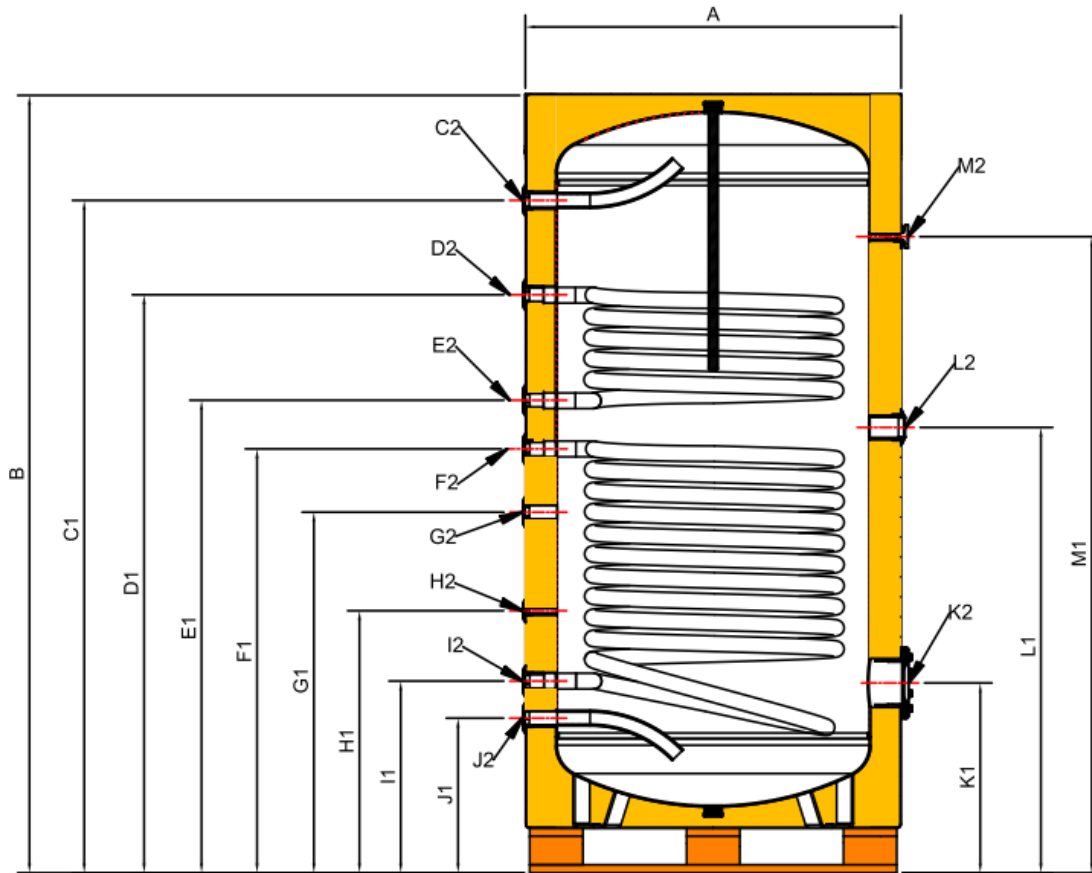

**DOUBLE COIL BOILER DIMENSION TABLE**

DIMENSION	DESCRIPTION		CAPACITY						
			500LT	800LT	1000LT	1500LT	2000LT	2500LT	3000LT
A	BOILER DIAMETER (INCLUDING INSULATION)	mm	800	1010	1010	1120	1260	1360	1440
B	HEIGHT	mm	1750	1810	2120	2532	2542	2666	2781
C1	HOT WATER OUTLET HEIGHT	mm	1490	1522	1835	2208	2210	2315	2415
C2	HOT WATER OUTLET DIAMETER	inc	1"	1 1/4"	1 1/4"	1 1/4"	1 1/4"	1 1/4"	1 1/4"
D1	COIL HOT WATER INLET HEIGHT	mm	1398	1377	1580	1855	1806	2054	2175
D2	COIL HOT WATER INLET DIAMETER	inc	1 1/4"	1 1/4"	1 1/4"	1 1/4"	1 1/4"	1 1/4"	1 1/4"
E1	COIL COLD WATER OUTLET HEIGHT	mm	1113	1092	1295	1514	1464	1655	1720
E2	COIL COLD WATER OUTLET DIAMETER	inc	1 1/4"	1 1/4"	1 1/4"	1 1/4"	1 1/4"	1 1/4"	1 1/4"
F1	COIL HOT WATER INLET HEIGHT	mm	1112	992	1164	1314	1264	1455	1470
F2	COIL HOT WATER INLET DIAMETER	inc	1 1/4"	1 1/4"	1 1/4"	1 1/4"	1 1/4"	1 1/4"	1 1/4"
G1	CIRCULATION HEIGHT	mm	846	862	993	963	960	1090	1105
G2	CIRCULATION DIAMETER	inc	1"	1 1/4"	1 1/4"	1 1/4"	1 1/4"	1 1/4"	1 1/4"
H1	TEMPERATURE SENSOR HEIGHT	mm	696	727	727	763	770	790	805
H2	TEMPERATURE SENSOR DIAMETER	inc	1/2"	1/2"	1/2"	1/2"	1/2"	1/2"	1/2"
I1	COIL COLD WATER OUTLET HEIGHT	mm	505	536	536	573	580	600	615
I2	COIL COLD WATER OUTLET DIAMETER	inc	1 1/4"	1 1/4"	1 1/4"	1 1/4"	1 1/4"	1 1/4"	1 1/4"
J1	COLD WATER INLET HEIGHT	mm	406	437	437	473	480	500	515
J2	COLD WATER INLET DIAMETER	inc	1 1/4"	1 1/4"	1 1/4"	1 1/4"	1 1/4"	1 1/4"	1 1/4"
K1	CLEANING COVER HEIGHT	mm	504	533	533	568	575	595	610
K2	CLEANING COVER DIAMETER		DN125	DN125	DN125	DN125	DN125	DN125	DN125
L1	HEATING ELEMENT HEIGHT	mm	1074	1042	1222	1414	1365	1555	1570
L2	HEATING ELEMENT DIAMETER	inc	1 1/4"	2"	2"	2"	2"	2"	2"
M1	THERMOMETER HEIGHT	mm	1442	1366	1737	2026	2023	2100	2160
M2	THERMOMETER DIAMETER	inc	1/2"	1/2"	1/2"	1/2"	1/2"	1/2"	1/2"

c. Accumulation Tank Dimension Table

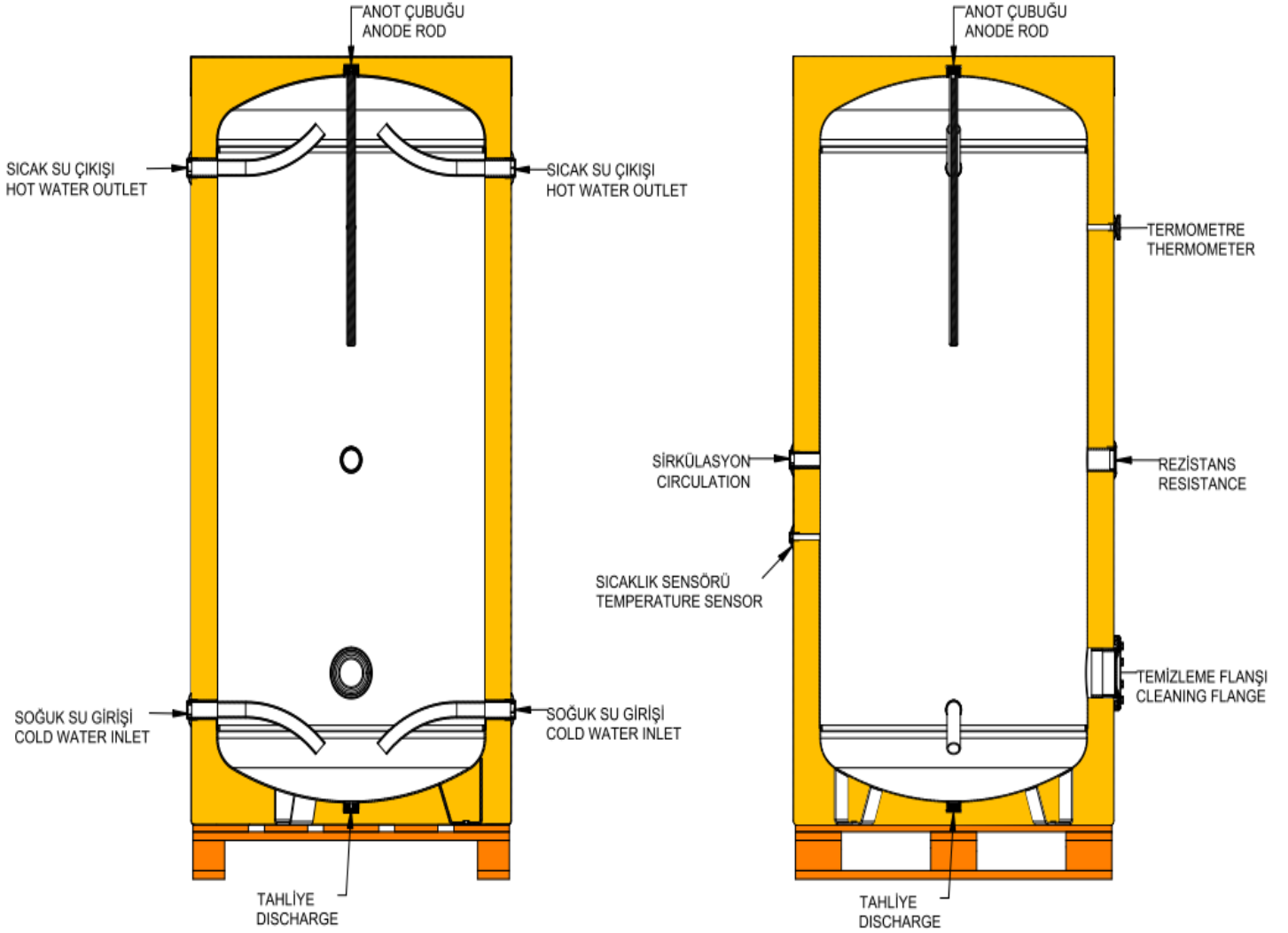

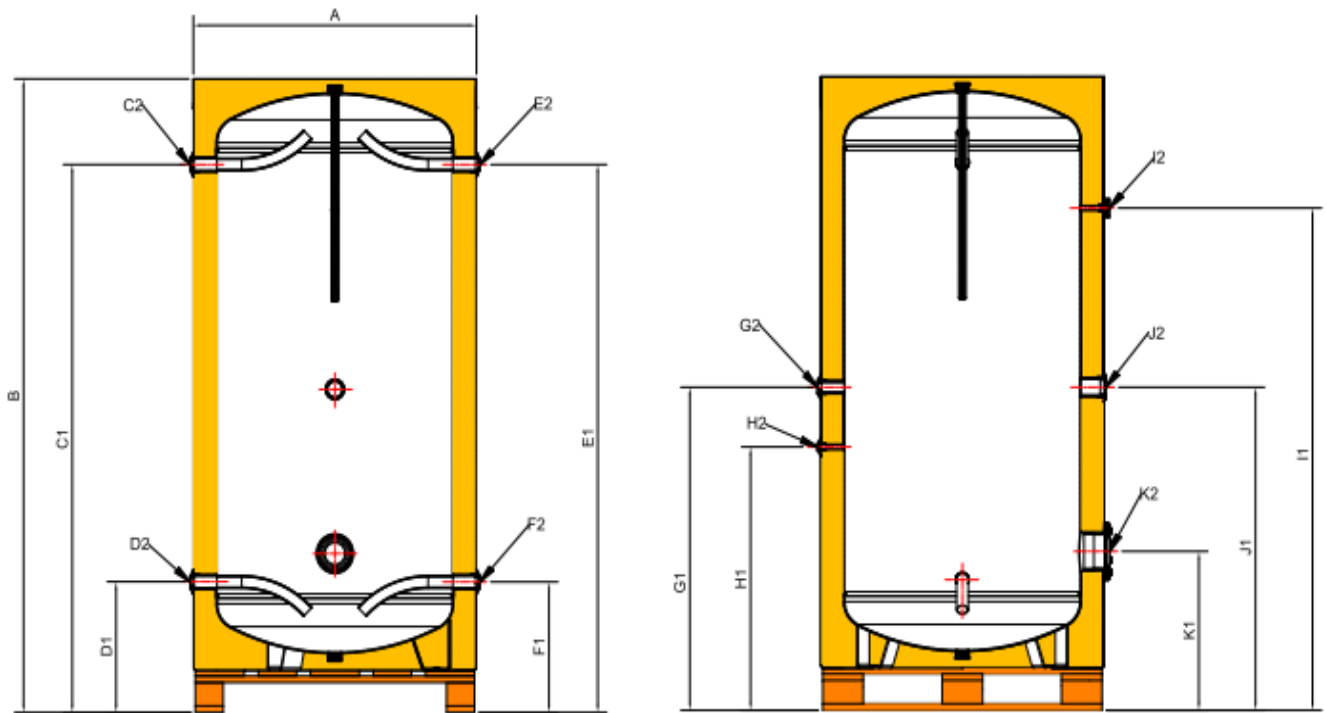

ACCUMULATION TANK DIMENSION TABLE

DIMENSION	DESCRIPTION		CAPACITY						
			500LT	800LT	1000LT	1500LT	2000	2500	3000
A	BOILER DIAMETER (INCLUDING INSULATION)	mm	800	1010	1010	1120	1260	1360	1440
B	HEIGHT	mm	1750	1810	2120	2532	2542	2666	2781
C1	HOT WATER OUTLET HEIGHT	mm	1470	1522	1835	2208	2210	2315	2415
C2	HOT WATER OUTLET DIAMETER	inc	1"	1 1/4"	1 1/4"	1 1/4"	1 1/4"	1 1/4"	1 1/4"
D1	COLD WATER INLET HEIGHT	mm	387	437	437	473	480	500	515
D2	COLD WATER INLET DIAMETER	inc	1"	1 1/4"	1 1/4"	1 1/4"	1 1/4"	1 1/4"	1 1/4"
E1	HOT WATER OUTLET HEIGHT	mm	1470	1522	1835	2208	2210	2315	2415
E2	HOT WATER OUTLET DIAMETER	inc	1"	1 1/4"	1 1/4"	1 1/4"	1 1/4"	1 1/4"	1 1/4"
F1	COLD WATER INLET HEIGHT	mm	387	437	437	473	480	500	515
F2	COLD WATER INLET DIAMETER	inc	1"	1 1/4"	1 1/4"	1 1/4"	1 1/4"	1 1/4"	1 1/4"
G1	CIRCULATION HEIGHT	mm	837	915	1082	1300	1250	1500	1460
G2	CIRCULATION DIAMETER	inc	1"	1 1/4"	1 1/4"	1 1/4"	1 1/4"	1 1/4"	1 1/4"
H1	TEMPERATURE SENSOR HEIGHT	mm	587	765	882	1100	1050	1250	1210
H2	TEMPERATURE SENSOR DIAMETER	inc	1/2"	1/2"	1/2"	1/2"	1/2"	1/2"	1/2"
I1	THERMOMETER HEIGHT	mm	1370	1366	1682	2026	2023	2043	2058
I2	THERMOMETER DIAMETER	inc	1/2"	1/2"	1/2"	1/2"	1/2"	1/2"	1/2"
J1	HEATING ELEMENT HEIGHT	mm	984	915	1082	1300	1250	1500	1460
J2	HEATING ELEMENT DIAMETER	inc	1 1/4"	2"	2"	2"	2"	2"	2"
K1	CLEANING COVER HEIGHT	mm	484	534	534	568	575	595	610
K2	CLEANING COVER DIAMETER		DN125	DN125	DN125	DN125	DN125	DN125	DN125

d. Electric Boiler Dimension Table

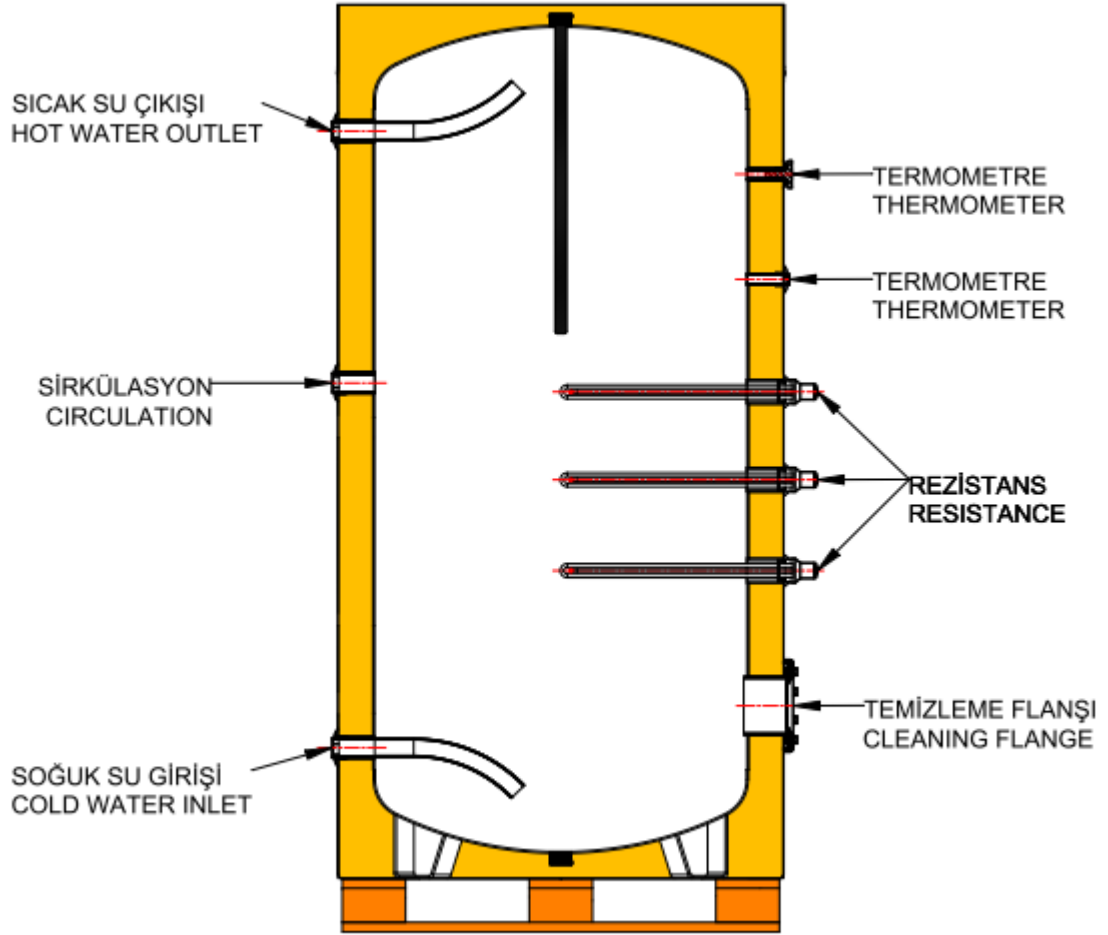

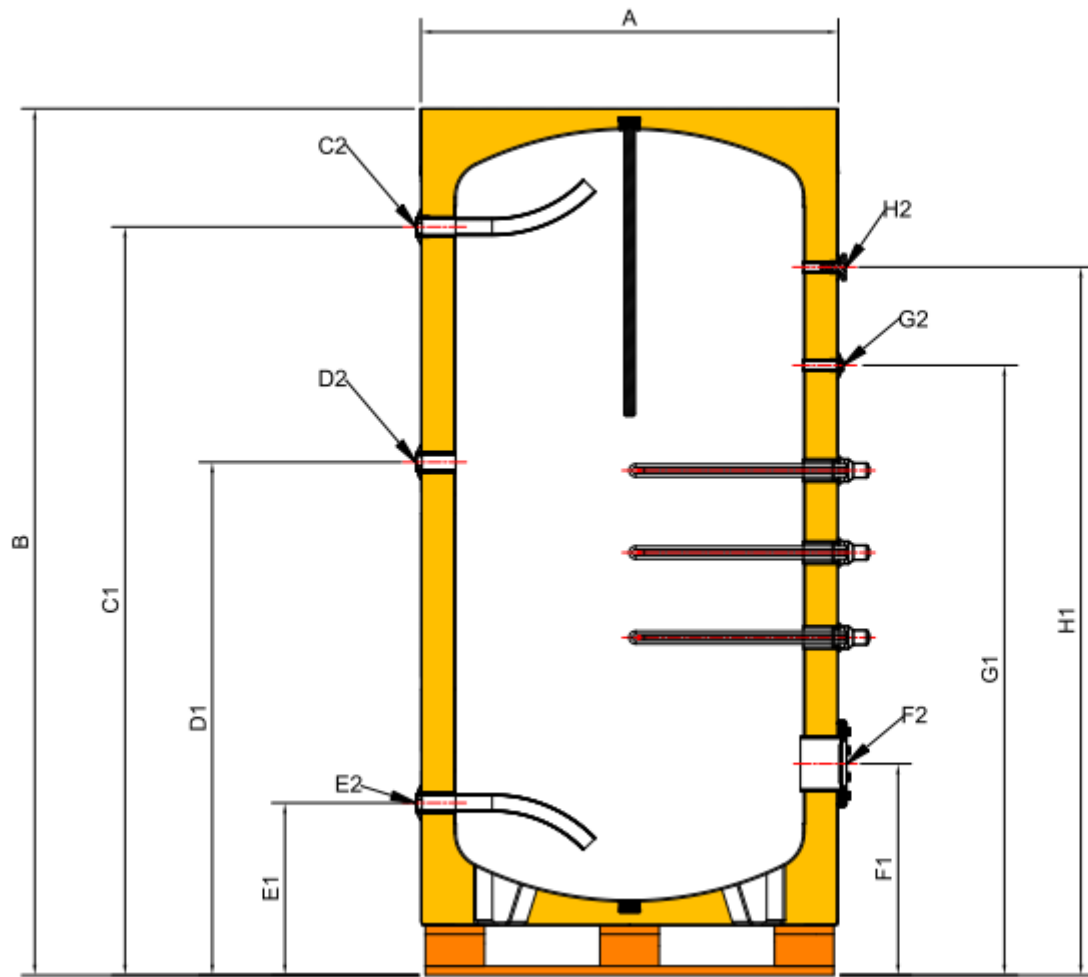

**ELECTRIC BOILER DIMENSION TABLE**

DIMENSION	DESCRIPTION		CAPACITY						
			500LT	800LT	1000LT	1500LT	2000LT	2500LT	3000LT
A	BOILER DIAMETER (INCLUDING INSULATION)	mm	800	1010	1010	1120	1260	1360	1440
B	HEIGHT	mm	1750	1810	2120	2532	2542	2666	2781
C1	HOT WATER OUTLET HEIGHT	mm	1470	1522	1835	2208	2210	2315	2415
C2	HOT WATER OUTLET DIAMETER	inc	1"	1 1/4"	1 1/4"	1 1/4"	1 1/4"	1 1/4"	1 1/4"
D1	CIRCULATION HEIGHT	mm	837	915	1082	1300	1250	1500	1460
D2	CIRCULATION DIAMETER	inc	1"	1 1/4"	1 1/4"	1 1/4"	1 1/4"	1 1/4"	1 1/4"
E1	COLD WATER INLET HEIGHT	mm	387	437	437	473	480	500	515
E2	COLD WATER INLET DIAMETER	inc	1"	1 1/4"	1 1/4"	1 1/4"	1 1/4"	1 1/4"	1 1/4"
F1	CLEANING COVER HEIGHT	mm	484	534	534	568	575	595	610
F2	CLEANING COVER DIAMETER		DN125	DN125	DN125	DN125	DN125	DN125	DN125
G1	TEMPERATURE SENSOR HEIGHT	mm	1284	1280	1600	1940	1940	1960	1970
G2	TEMPERATURE SENSOR DIAMETER	inc	1/2"	1/2"	1/2"	1/2"	1/2"	1/2"	1/2"
H1	THERMOMETER HEIGHT	mm	1370	1366	1682	2026	2023	2043	2058
H2	THERMOMETER DIAMETER	inc	1/2"	1/2"	1/2"	1/2"	1/2"	1/2"	1/2"

## 5. TECHNICAL DATA

### a. Single Coil

TECHNICAL SPECIFICATIONS	500	800	1000	1500	2000	2500	3000
Body Sheet Type	ST37	ST37	ST37	ST37	ST37	ST37	ST37
Operating Pressure	Max. 10bar	Max. 10bar	Max. 10bar	Max. 10bar	Max. 10bar	Max. 10bar	Max. 10bar
Test Pressure	Max. 13bar	Max. 13bar	Max. 13bar	Max. 13bar	Max. 13bar	Max. 13bar	Max. 13bar
Water Temperature	Max. 95°C	Max. 95°C	Max. 95°C	Max. 95°C	Max. 95°C	Max. 95°C	Max. 95°C
Inner Surface Coating	TS EN 12499 Titanium Enamel	TS EN 12499 Titanium Enamel	TS EN 12499 Titanium Enamel	TS EN 12499 Titanium Enamel	TS EN 12499 Titanium Enamel	TS EN 12499 Titanium Enamel	TS EN 12499 Titanium Enamel
Enamel Coating Thickness	250-450 Microns	250-450 Microns	250-450 Microns	250-450 Microns	250-450 Microns	250-450 Microns	250-450 Microns
Cathodic Protection Element	TS EN 12499 Standard Magnesium Anode	TS EN 12499 Standard Magnesium Anode	TS EN 12499 Standard Magnesium Anode	TS EN 12499 Standard Magnesium Anode	TS EN 12499 Standard Magnesium Anode	TS EN 12499 Standard Magnesium Anode	TS EN 12499 Standard Magnesium Anode
Insulation Thickness	50mm	80mm	80mm	80mm	80mm	80mm	80mm
Insulation Density	18 kg/m <sup>3</sup>	18kg/m <sup>3</sup>	18kg/m <sup>3</sup>	18kg/m <sup>3</sup>	18kg/m <sup>3</sup>	kg/m <sup>3</sup>	kg/m <sup>3</sup>
Thermal Conductivity Coefficient of Insulation	0,040 W/(m·K)	0,040 W/(m·K)	0,040 W/(m·K)	0,040 W/(m·K)	0,040 W/(m·K)	0,040 W/(m·K)	0,040 W/(m·K)
Insulation Type	Soft Polyurethane	Soft Polyurethane	Soft Polyurethane	Soft Polyurethane	Soft Polyurethane	Soft Polyurethane	Soft Polyurethane
Anode Connection	1 1/4 inch	1 1/4 inch	1 1/4 inch	1 1/4 inch	1 1/4 inch	1 1/4 inch	1 1/4 inch
Coil Inlet-Outlet Connection	1 1/4 inch	1 1/4 inch	1 1/4 inch	1 1/4 inch	1 1/4 inch	1 1/4 inch	1 1/4 inch
Thermometer Connection	1/2 inch	1/2 inch	1/2 inch	1/2 inch	1/2 inch	1/2 inch	1/2 inch
Cleaning Flange	5 inch	5 inch	5 inch	5 inch	5 inch	5 inch	5 inch
Recirculation Connection	1 inch	1 1/4 inch	1 1/4 inch	1 1/4 inch	1 1/4 inch	1 1/4 inch	1 1/4 inch
Heating Element Connection	1 1/4 inch	2 inch	2 inch	2 inch	2 inch	2 inch	2 inch
Cold-Hot Water Connection	1 inch	1 1/4 inch	1 1/4 inch	1 1/4 inch	1 1/4 inch	1 1/4 inch	1 1/4 inch
Coil Surface Area	2m <sup>2</sup>	2,9m <sup>2</sup>	3,2m <sup>2</sup>	4,4m <sup>2</sup>	5,1m <sup>2</sup>	6,4 m <sup>2</sup>	6,8m <sup>2</sup>
Coil Tube Diameter	42,4mm	42,4mm	42,4 mm	42,4mm	42,4 mm	42,4 mm	42,4 mm
Coil Length	15 Meters	22 Meters	24 Meters	33 Meters	38 Meters	48 Meters	51 Meters
Product Dimensions	Ø800x1750 mm	Ø1010x1810 mm	Ø1010x2120 mm	Ø1120x2530 mm	Ø1260x2540 mm	Ø1360x2665 mm	Ø1440x2780 mm

## b. Double Coil

TECHNICAL SPECIFICATIONS	500	800	1000	1500	2000	2500	3000
Product Inner Diameter	700mm	850mm	850mm	960mm	1100mm	1200mm	1280mm
Product Outer Diameter	800mm	1010mm	1010mm	1120mm	1260mm	1360mm	1440mm
Height	1750mm	1810mm	2120mm	2530mm	2540mm	2665mm	2780mm
Body Sheet Type	ST37	ST37	ST37	ST37	ST37	ST37	ST37
Body Sheet Thickness	4mm	4mm	4mm	5mm	5mm	6mm	6mm
Dished Head Sheet Thickness	4mm	4mm	4mm	5mm	5mm	6mm	6mm
Operating Pressure	Max. 10bar	Max. 10bar	Max. 10bar	Max. 10bar	Max. 10bar	Max. 10bar	Max. 10bar
Test Pressure	Max. 13bar	Max. 13bar	Max. 13bar	Max. 13bar	Max. 13bar	Max. 13bar	Max. 13bar
Water Temperature	Max. 95°C	Max. 95°C	Max. 95°C	Max. 95°C	Max. 95°C	Max. 95°C	Max. 95°C
Inner Surface Coating	TS EN 12499 Titanium Enamel	TS EN 12499 Titanium Enamel	TS EN 12499 Titanium Enamel	TS EN 12499 Titanium Enamel	TS EN 12499 Titanium Enamel	TS EN 12499 Titanium Enamel	TS EN 12499 Titanium Enamel
Enamel Coating Thickness	250-450 Microns	250-450 Microns	250-450 Microns	250-450 Microns	250-450 Microns	250-450 Microns	250-450 Microns
Cathodic Protection Element	TS EN 12499 Standard Magnesium Anode	TS EN 12499 Standard Magnesium Anode	TS EN 12499 Standard Magnesium Anode	TS EN 12499 Standard Magnesium Anode	TS EN 12499 Standard Magnesium Anode	TS EN 12499 Standard Magnesium Anode	TS EN 12499 Standard Magnesium Anode
Insulation Thickness	50mm	80mm	80mm	80mm	80mm	80mm	80mm
Insulation Density	18kg/m <sup>3</sup>	18kg/m <sup>3</sup>	18kg/m <sup>3</sup>	18kg/m <sup>3</sup>	18kg/m <sup>3</sup>	18kg/m <sup>3</sup>	18kg/m <sup>3</sup>
Thermal Conductivity Coefficient of Insulation	0,040 W/(m·K)	0,040 W/(m·K)	0,040 W/(m·K)	0,040 W/(m·K)	0,040 W/(m·K)	0,040 W/(m·K)	0,040 W/(m·K)
Insulation Type	Soft Polyurethane	Soft Polyurethane	Soft Polyurethane	Soft Polyurethane	Soft Polyurethane	Soft Polyurethane	Soft Polyurethane
Anode Connection	1 1/4 inch	1 1/4 inch	1 1/4 inch	1 1/4 inch	1 1/4 inch	1 1/4 inch	1 1/4 inch
Upper Coil Inlet-Outlet Connection	1 1/4 inch	1 1/4 inch	1 1/4 inch	1 1/4 inch	1 1/4 inch	1 1/4 inch	1 1/4 inch
Thermometer Connection	1/2 inch	1/2 inch	1/2 inch	1/2 inch	1/2 inch	1/2 inch	1/2 inch
Cleaning Flange	5 inch	5 inch	5 inch	5 inch	5 inch	5 inch	5 inch
Recirculation Connection	1 inch	1 1/4 inch	1 1/4 inch	1 1/4 inch	1 1/4 inch	1 1/4 inch	1 1/4 inch
Heating Element Connection	1 1/4 inch	2 inch	2 inch	2 inch	2 inch	2 inch	2 inch
Cold-Hot Water Connection	1 inch	1 1/4 inch	1 1/4 inch	1 1/4 inch	1 1/4 inch	1 1/4 inch	1 1/4 inch
Upper Coil Surface Area	1,7m <sup>2</sup>	1,3 m <sup>2</sup>	1,4m <sup>2</sup>	1,55m <sup>2</sup>	2,2 m <sup>2</sup>	2,8 m <sup>2</sup>	3,1m <sup>2</sup>
Upper Coil Tube Diameter	42,4 mm	42,4mm	42,4 mm	42,4mm	42,4mm	42,4 mm	42,4 mm
Upper Coil Length	9 Meters	10 Meters	11 Meters	12 Meters	16,3 Meters	21,3 Meters	24 Meters
Lower Coil Surface Area	2m <sup>2</sup>	2,9m <sup>2</sup>	3,2m <sup>2</sup>	4,4m <sup>2</sup>	5,1 m <sup>2</sup>	6,4 m <sup>2</sup>	6,8m <sup>2</sup>
Lower Coil Tube Diameter	42,4 mm	42,4mm	42,4 mm	42,4mm	42,4mm	42,4 mm	42,4 mm
Lower Coil Length	15 Meters	22 Meters	24 Meters	33 Meters	38 Meters	48 Meters	51 Meters
Lower Coil Inlet-Outlet Connection	1 1/4 inch	1 1/4 inch	1 1/4 inch	1 1/4 inch	1 1/4 inch	1 1/4 inch	1 1/4 inch
Product Dimensions	Ø800x1750 mm	Ø1010x1810 mm	Ø1010x2120 mm	Ø1120x2530 mm	Ø1260x2540 mm	Ø1360x2665 mm	Ø1440x2780 mm

### c. Accumulation Tank

TECHNICAL SPECIFICATIONS	500	800	1000	1500	2000	2500	3000
Product Inner Diameter	700mm	850mm	850mm	960mm	1100mm	1200mm	1280mm
Product Outer Diameter	800mm	1010mm	1010mm	1120mm	1260mm	1360mm	1440mm
Height	1750mm	1810mm	2120mm	2530mm	2540mm	2665mm	2780mm
Body Sheet Metal Type	ST37	ST37	ST37	ST37	ST37	ST37	ST37
Body Sheet Metal Thickness	4mm	4mm	4mm	5mm	5mm	6mm	6mm
Dished End Sheet Thickness	4mm	4mm	4mm	5mm	5mm	6mm	6mm
Working Pressure	Max. 10bar	Max. 10bar	Max. 10bar	Max. 10bar	Max. 10bar	Max. 10bar	Max. 10bar
Test Pressure	Max. 13bar	Max. 13bar	Max. 13bar	Max. 13bar	Max. 13bar	Max. 13bar	Max. 13bar
Water Temperature	Max. 95°C	Max. 95°C	Max. 95°C	Max. 95°C	Max. 95°C	Max. 95°C	Max. 95°C
Internal Surface Coating	TS EN 12499 Titanium Enamel	TS EN 12499 Titanium Enamel	TS EN 12499 Titanium Enamel	TS EN 12499 Titanium Enamel	TS EN 12499 Titanium Enamel	TS EN 12499 Titanium Enamel	TS EN 12499 Titanium Enamel
Enamel Coating Thickness	250-450 Microns	250-450 Microns	250-450 Microns	250-450 Microns	250-450 Microns	250-450 Microns	250-450 Microns
Cathodic Protection Element	TS EN 12499 Standard Magnesium Anode	TS EN 12499 Standard Magnesium Anode	TS EN 12499 Standard Magnesium Anode	TS EN 12499 Standard Magnesium Anode	TS EN 12499 Standard Magnesium Anode	TS EN 12499 Standard Magnesium Anode	TS EN 12499 Standard Magnesium Anode
Insulation Thickness	50mm	80mm	80mm	80mm	80mm	80mm	80mm
Insulation Density	18kg/m <sup>3</sup>	18kg/m <sup>3</sup>	18kg/m <sup>3</sup>	18kg/m <sup>3</sup>	18kg/m <sup>3</sup>	18kg/m <sup>3</sup>	18kg/m <sup>3</sup>
Thermal Conductivity Coefficient of Insulation	0,040 W/(m·K)	0,040 W/(m·K)	0,040 W/(m·K)	0,040 W/(m·K)	0,040 W/(m·K)	0,040 W/(m·K)	0,040 W/(m·K)
Type of Insulation	Soft Polyurethane	Soft Polyurethane	Soft Polyurethane	Soft Polyurethane	Soft Polyurethane	Soft Polyurethane	Soft Polyurethane
Anode Connection	1 1/4 inch	1 1/4 inch	1 1/4 inch	1 1/4 inch	1 1/4 inch	1 1/4 inch	1 1/4 inch
Thermometer Connection	1/2 inch	1/2 inch	1/2 inch	1/2 inch	1/2 inch	1/2 inch	1/2 inch
Cleaning Flange	5 inch	5 inch	5 inch	5 inch	5 inch	5 inch	5 inch
Recirculation Connection	1 inch	1 1/4 inch	1 1/4 inch	1 1/4 inch	1 1/4 inch	1 1/4 inch	1 1/4 inch
Cold and Hot Water Connection	1 inch	1 1/4 inch	1 1/4 inch	1 1/4 inch	1 1/4 inch	1 1/4 inch	1 1/4 inch
Heating Element Connection	1 1/4 inch	2 inch	2 inch	2 inch	2 inch	2 inch	2 inch
Product Dimensions	Ø800x1750 mm	Ø1010x1810 mm	Ø1010x2120 mm	Ø1120x2530 mm	Ø1260x2540 mm	Ø1360x2665 mm	Ø1440x2780 mm

#### d. Electric Boiler

TECHNICAL SPECIFICATIONS	500	800	1000	1500	2000	2500	3000
Product Inner Diameter	700mm	850mm	850mm	960mm	1100mm	1200mm	1280mm
Product Outer Diameter	800mm	1010mm	1010mm	1120mm	1260mm	1360mm	1440mm
Height	1750mm	1810mm	2120mm	2530mm	2540mm	2665mm	2780mm
Body Sheet Type	ST37	ST37	ST37	ST37	ST37	ST37	ST37
Body Sheet Thickness	4mm	4mm	4mm	5mm	5mm	6mm	6mm
Dished End Plate Thickness	4mm	4mm	4mm	5mm	5mm	6mm	6mm
Operating Pressure	Max. 10bar	Max. 10bar	Max. 10bar	Max. 10bar	Max. 10bar	Max. 10bar	Max. 10bar
Test Pressure	Max. 13bar	Max. 13bar	Max. 13bar	Max. 13bar	Max. 13bar	Max. 13bar	Max. 13bar
Water Temperature	Max. 95°C	Max. 95°C	Max. 95°C	Max. 95°C	Max. 95°C	Max. 95°C	Max. 95°C
Internal Surface Coating	TS EN 12499 Titanium Enamel	TS EN 12499 Titanium Enamel	TS EN 12499 Titanium Enamel	TS EN 12499 Titanium Enamel	TS EN 12499 Titanium Enamel	TS EN 12499 Titanium Enamel	TS EN 12499 Titanium Enamel
Enamel Coating Thickness	250-450 Microns	250-450 Microns	250-450 Microns	250-450 Microns	250-450 Microns	250-450 Microns	250-450 Microns
Cathodic Protection Element	TS EN 12499 Standard Magnesium Anode	TS EN 12499 Standard Magnesium Anode	TS EN 12499 Standard Magnesium Anode	TS EN 12499 Standard Magnesium Anode	TS EN 12499 Standard Magnesium Anode	TS EN 12499 Standard Magnesium Anode	TS EN 12499 Standard Magnesium Anode
Insulation Thickness	50mm	80mm	80mm	80mm	80mm	80mm	80mm
Insulation Density	18kg/m <sup>3</sup>	18kg/m <sup>3</sup>	18kg/m <sup>3</sup>	18kg/m <sup>3</sup>	18kg/m <sup>3</sup>	18kg/m <sup>3</sup>	18kg/m <sup>3</sup>
Thermal Conductivity Coefficient of Insulation	0,040 W/(m·K)	0,040 W/(m·K)	0,040 W/(m·K)	0,040 W/(m·K)	0,040 W/(m·K)	0,040 W/(m·K)	0,040 W/(m·K)
Type of Insulation	Soft Polyurethane	Soft Polyurethane	Soft Polyurethane	Soft Polyurethane	Soft Polyurethane	Soft Polyurethane	Soft Polyurethane
Anode Connection	1 1/4 inch	1 1/4 inch	1 1/4 inch	1 1/4 inch	1 1/4 inch	1 1/4 inch	1 1/4 inch
Thermometer Connection	1/2 inch	1/2 inch	1/2 inch	1/2 inch	1/2 inch	1/2 inch	1/2 inch
Cleaning Flange	5 inch	5 inch	5 inch	5 inch	5 inch	5 inch	5 inch
Recirculation Connection	1 inch	1 1/4 inch	1 1/4 inch	1 1/4 inch	1 1/4 inch	1 1/4 inch	1 1/4 inch
Heating Element Connection	1 1/2 inch	1 1/2 inch	1 1/2 inch	1 1/2 inch	1 1/2 inch	1 1/2 inch	1 1/2 inch
Cold and Hot Water Connection	1 inch	1 1/4 inch	1 1/4 inch	1 1/4 inch	1 1/4 inch	1 1/4 inch	1 1/4 inch
Product Dimensions	Ø800x1750 mm	Ø1010x1810 mm	Ø1010x2120 mm	Ø1120x2530 mm	Ø1260x2540 mm	Ø1360x2665 mm	Ø1440x2780 mm
Heating Power	2x10 kW	2x15 kW	3x15 kW	4x15 kW	5x15 kW	7x 15 kW	7x15kW
Hot Water Capacity (L/H) at 10°C – 45°C	489	730	1050	1472	1850	2100	2100

## **6. CLOSED SYSTEM CIRCUIT COMPONENTS**

### **6.1. Expansion Tank**

The expansion tank pre-charge pressures must be adjusted in accordance with the system requirements. The expansion tank should be installed in parallel with the system return line.

### **6.2. Pressure Gauge**

It is used to indicate the pressure value within the system.

### **6.3. Dirt Separator**

Impurities such as dirt, sludge, and sediment contained in the system water may cause malfunctions in the boiler and installation components, increased stress on heat transfer surfaces, and reduced efficiency. To prevent this, a dirt separator is added to the system.

### **6.4. Air Separator**

Air contained within the system piping dissolves and circulates in the system in gaseous form as the temperature increases. This air in the installation may cause cavitation, reduced efficiency, and noise. By using an air separator, the air present in the system is removed from the installation.

### **6.5. Check Valve**

It allows the fluid flowing within the system to move in the desired direction and prevents reverse flow of the fluid.

### **6.6. Pump**

It is used to ensure the circulation of the fluid used in the system within the installation.

### **6.7. Thermometer**

It is used to monitor the temperature of the fluid within the system.

### **6.8. Pressure Reducing Valve**

If the water pressure in the line exceeds the device's permitted optimal pressure, a pressure reducing valve must be installed on the connection line.



To ensure the system operates smoothly and that deficiencies in the installation do not cause efficiency losses, the hydraulic piping design must comply with the circuit diagrams specified in the hydraulic system design manual. The hydraulic system must be equipped with a buffer tank, sludge separator, air separator, and expansion tank appropriate to the system's capacity and characteristics.



It is beneficial to integrate a water softening system into the installation to balance the pH level.

## 7. CIRCUIT DIAGRAMS

### a. Single Coil Boiler Circuit Diagram

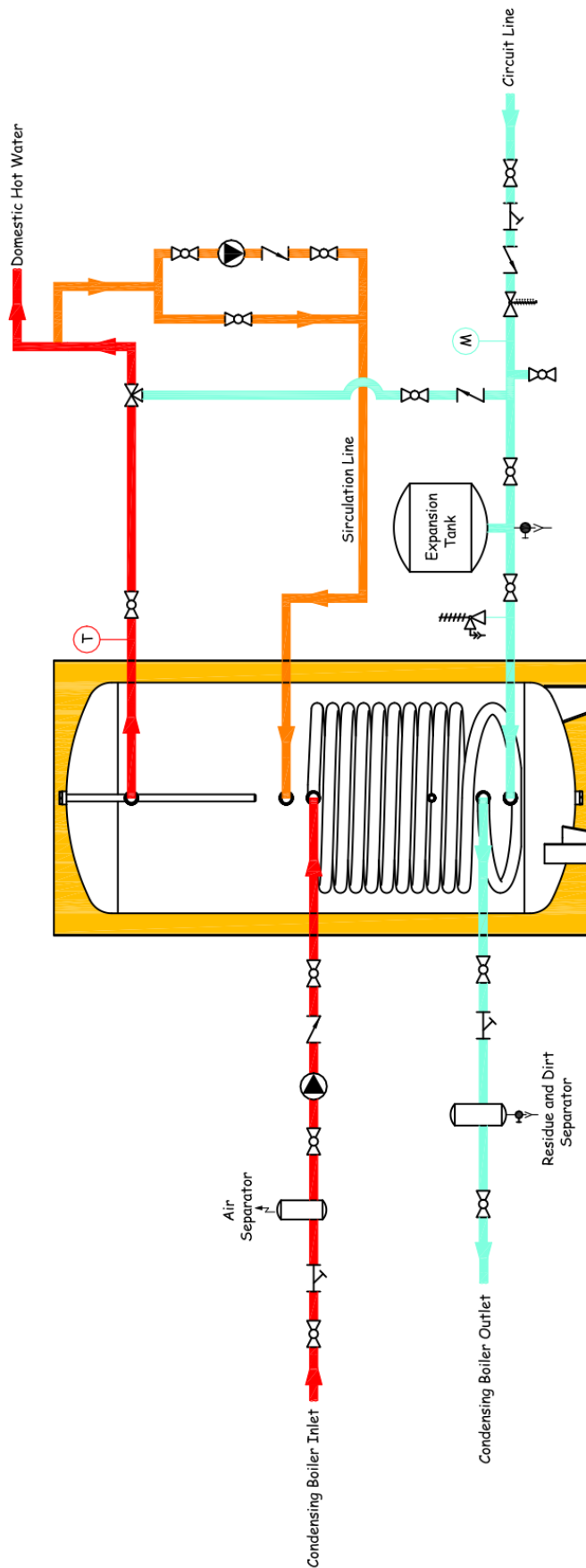

b. Double Coil Boiler Circuit Diagram

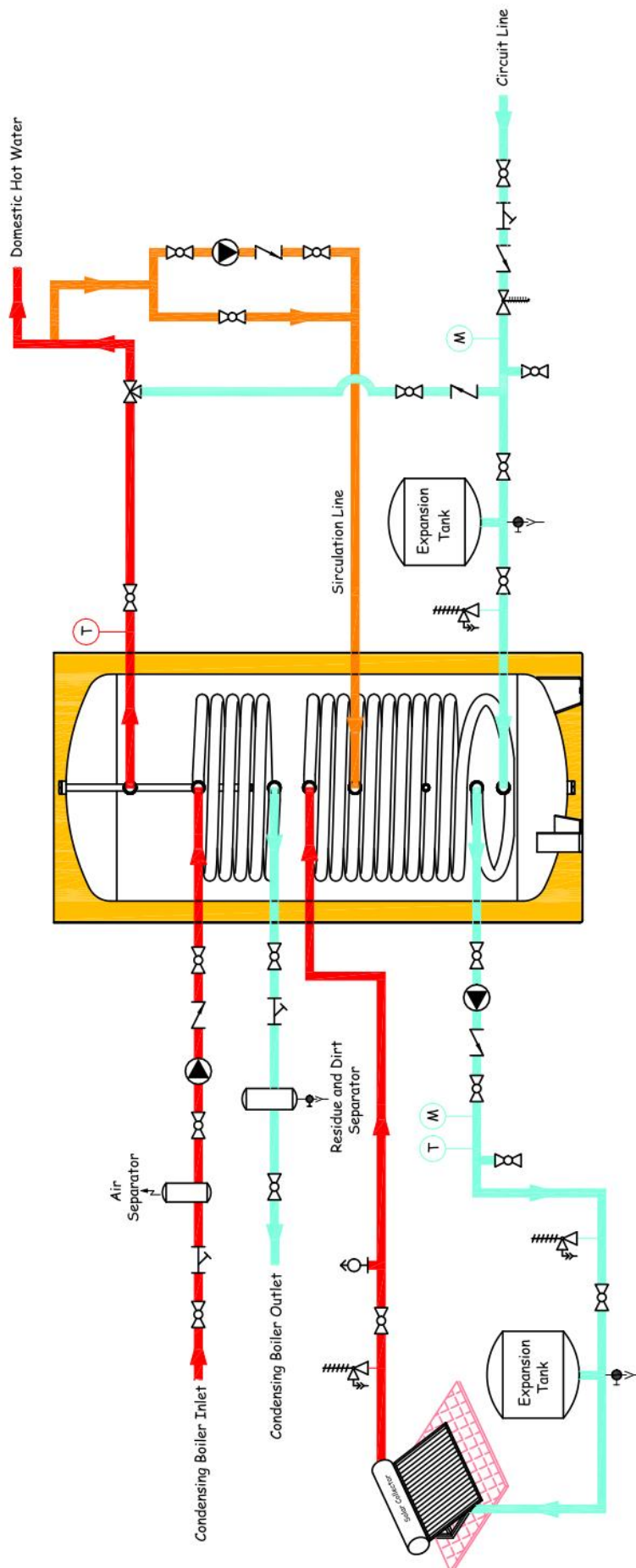

c. Accumulation Tank Circuit Diagram

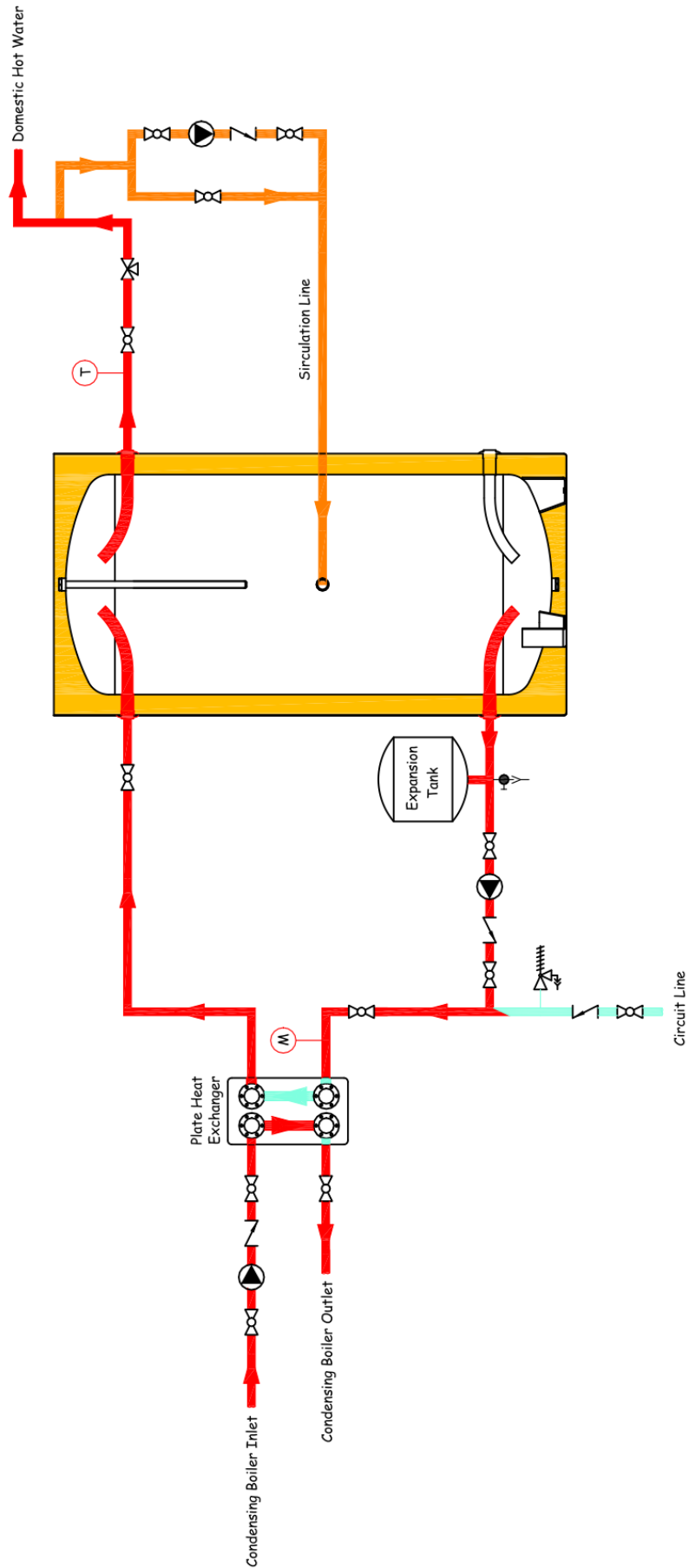

d. Electric Boiler Circuit Diagram

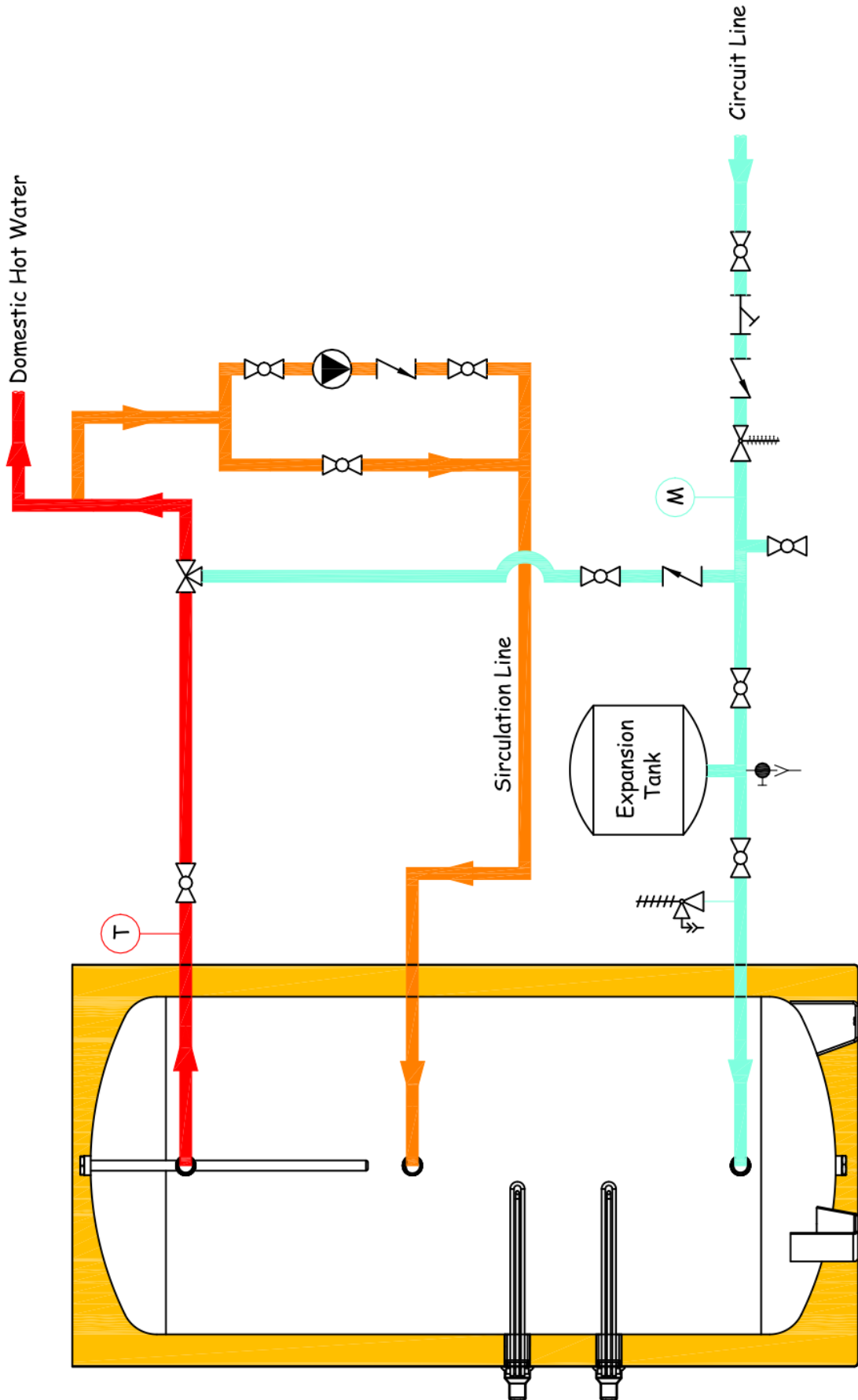

## 8. EQUIPMENT PLACEMENT AND INSTALLATION REQUIREMENTS

- The products are shipped on wooden pallets for transportation purposes. The pallet must be removed before installation.
- Install your device according to the connection diagram appropriate for the product model.
- For placing the device, a base must be constructed on a solid and level surface capable of supporting the weight of the boiler.
- The installation location must be determined by leaving sufficient space for maintenance, repair, or replacement operations in case of malfunction.
- Your device must be installed in an enclosed area or a place where there is no risk of freezing.
- For your device to operate efficiently, the installation system must be completed exactly as shown in the diagram, and the capacity of the heat sources must be selected according to the hot water demand.
- The product is not covered by warranty in case of inefficient operation or physical damage caused by installation errors.
- The device will not be covered by warranty if an automatic safety valve is not installed, is defective, or is not connected properly.
- Precautions against fire and flooding must be taken in the area where the device is installed. Our company is not responsible for any situations or expenses arising from equipment failure or other adverse conditions.



Failures caused by not using the installation components (such as safety valve, check valve, valve, etc.) specified in the installation connection diagram and/or by not installing them in the correct sequence as shown in the diagram are **NOT COVERED BY THE WARRANTY**.



The device must be transported in its original packaging!



**THE MOST IMPORTANT POINT TO CONSIDER DURING BOILER INSTALLATION IS CONNECTING A SAFETY VALVE TO THE SYSTEM.**

Water expands as it is heated. For example, with a temperature increase of 50 °C, the volume of water increases by 1.19%. This excess water must be discharged.

Water is not like air; it is incompressible. If the expanding water is not discharged from the boiler, it exerts pressure on the body and may cause the boiler to rupture at its weakest point.

## **9. COMMISSIONING**

The water to be used in your device must be conditioned in accordance with Drinking and Domestic Water Standards.

If the water used in the device does not comply with these standards, the product will be excluded from the warranty.

Check the mechanical and electrical connections of the product.

Check all connections and pipes for leaks.

Optionally, boilers with electric heating elements must be grounded. When working on the device's connection systems, the power supply circuits must be disconnected. If PPRC pipes are used, the boiler must also be grounded.

## **10. EXPANSION TANK APPLICATION**

The volume of the closed expansion tank to be installed on the cold water inlet side of the device must be selected to be at least 10% of the device volume. The expansion tank can operate at a maximum pressure of 10 bar, and its pre-charge pressure must be set to 10% below the operating pressure..

The most important point to consider regarding the device equipment is the connection of an automatic safety valve and an expansion tank to the system. Always install the expansion tank and safety valve between the device and the valve.

The pre-charge pressure of the expansion tank must be checked at least twice a year.

## 11. ECONDENSE BOILER PRE-COMMISSIONING CHECK INSTRUCTIONS

Do not operate your device without ensuring that it is completely filled with water and that the cold water inlet is open.

After completely filling your device with water, open the hot water tap to remove the air inside the product.

When starting to use the boiler, first activate the cold water side and then the hot water side. When draining, start with the hot water side and then proceed with the cold water side.

During first use, leave the hot water tap open for a while to clean the hot water circuit, allowing any possible deposits in the coils to be flushed out and trapped air to be discharged. Then start filling the boiler tank from the cold water inlet. While filling continues, use the air release valves (bleeders), which are mandatory in the system, to remove any air remaining in the installation.

Have the electrical connections of electric products carried out by a qualified electrician.

For electric products, check the required cable cross-section, voltage, and grounding line, and adjust the safety thermostat inside the panel.

Do not operate the heating element (resistance) in electric products before the unit is filled with water.

After final checks, your device is ready to produce hot water. The water temperature inside the boiler tank can be monitored via the thermometer on the control panel.



Pay attention to ensuring that all air in the system is completely removed via air vents (bleeders) during filling of the boiler, and that the discharge water from the safety valve installed on the inlet water line is properly connected to a drain.

## 12. MAINTENANCE

- To ensure that your device always performs at the desired level, it is recommended that limescale, dirt, and sediment that may form inside the heating element and boiler due to mains water hardness be periodically cleaned by opening the cleaning flange and cleaning the interior of the product.
- If your device operates with an electric heater, disconnect the electrical supply to the device.
- The gaskets on the product are single-use. If any components containing gaskets are disassembled for any reason, do not reuse the gasket. Contact the supplier.
- Ensure that system components such as valves, check valves, strainers, safety valves, expansion tanks, and thermometers are in good working condition.
- Clean the strainer filter by removing it at regular intervals.
- The magnesium anode installed in the unit should be inspected every six months. Following the initial inspection, the inspection interval should be determined based on the degree of anode wear.
- If the diameter of the magnesium anode drops below 12 mm, it must be replaced. (The original thickness of the magnesium anode in the product is 26 mm.)
- The magnesium anode is not covered under warranty.
- When the device is taken out of operation, precautions must be taken to prevent freezing, and the boiler must be drained.
- When cleaning the interior of the product, do not damage the enamel under any circumstances.
- After cleaning the product, ensure the watertight sealing of the cleaning flange and thermowell thermostat connection points.
- If depleted magnesium anodes and/or anodes thinner than 12 mm are not replaced, the product will be excluded from warranty coverage.

### **13. THINGS TO DO BEFORE CALLING THE AUTHORIZED SERVICE**

#### **A. If the unit's heating element (optional) is not working;**

There may be a power outage,

The circuit breaker may be switched off,

The main building fuse may have tripped.

#### **B. If hot water is not coming from the tap;**

The water supply may be cut off,

The unit's hot/cold water valve may be closed,

The strainer (filter) may be clogged .

#### **C. If water is flowing from the tap but not hot:**

The heating system or solar collector may not be operating,

The heating system may be running but the circulation pump may not be working.

#### **D. If sufficient hot water cannot be obtained from the boiler;**

The unit capacity may not have been selected according to demand,

Hot water may be flowing back into the supply line due to the absence of a check valve on the cold water inlet,

There may be a problem in the automation/control system.

#### **E. If the safety valve on the unit is discharging water;**

The supply pressure may be equal to or higher than 7 bar,

Debris may have entered the sealing surface of the safety valve.

## 14. AFTER-SALES SERVICES

Dear Customer,

We believe that providing good service is just as important as providing good products. For this reason, we continue to offer our informed consumers a wide range of services.

For your suggestions, complaints, and service requests:  
**Çağla Plaza, Atakent, Mithatpaşa Cd. No:116, 34760**  
**Ümraniye/İSTANBUL/TÜRKİYE**  
**Tel: 444 8 326**  
**Fax: +90 216 370 45 03**

Factory Contact Information:  
**Türkgücü OSB**  
**Bülent Ecevit Bulvarı No:11**  
**ÇORLU/TEKİRDAĞ/TÜRKİYE**  
**Tel: +90 282 685 44 80-81**  
**Fax: +90 282 685 42 09**

You can also reach us via **www.ecodense.com** by filling out the service request form, or by sending an e-mail to **servis@ecodense.com**



We kindly request that you follow the recommendations below.

- Use your product in accordance with the instructions in the manual.
- If you have a service request regarding your product, you may contact our Service Center using the phone numbers above.
- When you purchase the product, ensure that the Warranty Certificate is approved during installation.

ecodense  
CONDENSING BOILER



ecodense  
CONDENSING BOILER

Scan the QR Code  
to Reach Our  
Authorized Services



For detailed information, please contact our call center  
at **444 8 326**

