

MONOBLOCK HP GAS BURNERS INSTALLATION, OPERATING AND MAINTENANCE MANUAL

ONE-STAGE, TWO STAGE AND MODULATING OPERATION

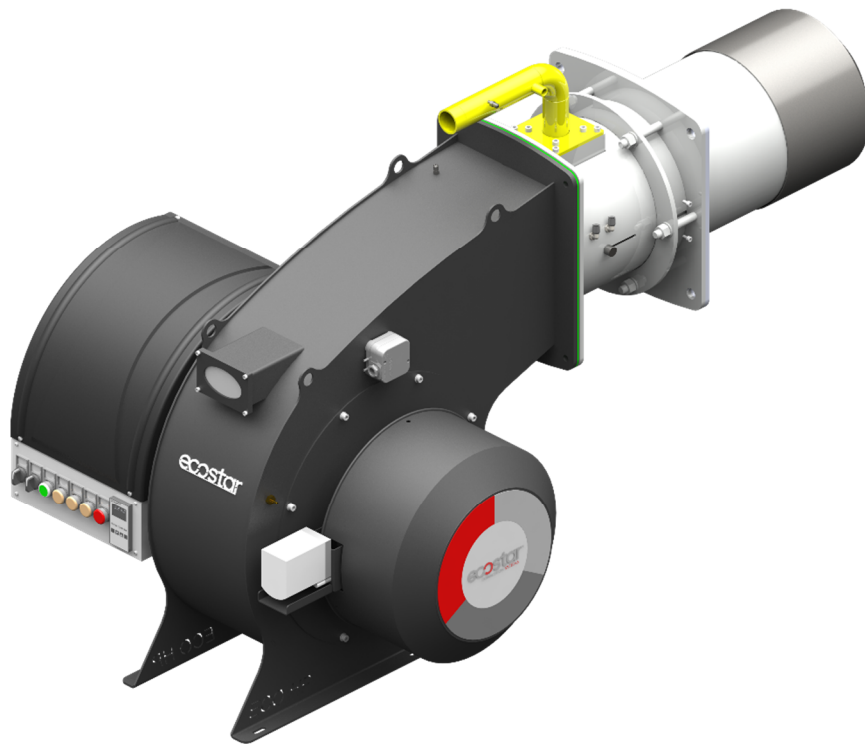

ECO 50 HP
ECO 100 HP
ECO 200 HP
ECO 350 HP
ECO 450 HP
ECO 700 HP
ECO 1100 HP
ECO 1500 HP
ECO 2000 HP
ECO 3000 HP
ECO 4500 HP



DEAR USER,

ECOSTAR ECO 50 HP, ECO 100 HP, ECO 200 HP, ECO 350 HP, ECO 450 HP, ECO 700 HP, ECO 1100 HP, ECO 1500 HP, ECO 2000 HP, ECO 3000 HP, ECO 4500 HP, Gas burners are prepared and manufactured according to the latest technical developments and safety rules. It is easy to use for our customers.

We recommend that you read this manual and safety warnings thoroughly before the use of the device in order to ensure safe, cost effective and environmental-friendly use.

If you encounter any issue that is not explained clearly in this manual or you could not understand, please contact with our service department.

We thank you for choosing ECOSTAR brand.

Ecostar Gas Burners are manufactured in accordance with TS EN 676 +A2 standards.







This Operating Manual is an integral part of the burner and must be maintained in a plastic dossier and hung at a clearly visible place in the burner room.

CONTENTS

1.	WARNINGS	3
1.1.	Warning Symbols and Descriptions	3
1.2.	General Safety Rules	4
2.	TERMS OF WARRANTY	6
2.1.	Out of Warranty Conditions	6
3.	BURNER'S GENERAL FEATURES	7
3.1.	Purpose of Use and Work Limits of Burners	7
3.2.	Code Key	7
3.3.	Burner Components	8
4.	GAS, FLUE GAS AND HEATING WATER SCHEMA	30
5.	TECHNICAL DATA	31
5.1.	Capacity Table	31
5.2.	Back Pressure and Gas Line Selection Table	34
5.3.	Gas Valve Outlet Pressure	42
5.4.	Burner Dimensions	46
5.5.	Flame Length and Diameter	48
5.6.	Noise Level	48
6.	BURNER HANDLING INFORMATION	48
7.	INSTALLATION	49
7.1.	Burner Installation Picture	49
8.	COMMISSIONING	51
8.1.	Before Commissioning	51
8.1.1.	Ignition and Ionizasyon System	51
8.2.	General Controls	51
8.3.	Combustion Adjustment	53
8.3.1.	Gas Adjustment	53
8.3.1.1.	VGD 20 4011 - 5011 Series Gas Valve	53
8.3.1.2.	MB DLE Series Monoblock Gas Valve	54
8.3.1.3.	MB ZRD(LE) 415 – 420 Series Gas Valve	56
8.4.	Air Pressure Switch Adjustment	57
8.5.	Servomotor Adjustment	57
8.6.	Emission Measurement	58
8.7.	Capacity Adjustment	58
8.8.	Burner Control System	59
8.8.1.	Inputs and Outputs / Internal Connection Diagram	60
8.8.2.	Error code list with operation via internal led	61
8.8.3.	Operating Control and Displays (Optional Usage)	62
8.9.	Gas Pass Equipment Required in Gas Line	65
9.	MAINTENANCE	66
9.1.	Monthly Maintenance	66
9.2.	Seasonal Maintenance	66
10.	TROUBLESHOOTING	67
11.	PERIODICAL FLUE GAS MEASUREMENT REPORT	68
12.	AFTER-SALES SERVICES	69
13.	NOTES	70

1. WARNINGS

1.1.Warning Symbols and Descriptions

Symbols	Symbol Descriptions
	Important information and useful hints.
	Warning of danger to life or property.
	Warning of electrical voltage.
	Product handling information.
P_F	Impulse connection detecting combustion chamber pressure
P_L	Impulse connection detecting combustion air pressure
P_{BR}	Impulse connection detecting burner gas head
 CLEAN THE GAS BURNER. CLEAN GAS LINE. ЧИСТАЯ ЛИНИЯ ГАЗ.	"Clean the gas line" warning on gas line.
	Electric motor direction of rotation
	Carry in an upright position. Fragile Item. Protect against water.

1.2. General Safety Rules

- All personnel engaged in installation, disassembly, commissioning, operation, control, maintenance and repair should have received the necessary training, qualified and fully read and understood this manual.
- No changes that might damage the safety of the burner unit must be made by persons and/or organizations on the burner unit.
- All operation, commissioning and installation works (except for burning adjustment) should be carried out when the burner is not operating and after disconnecting the power supply. Noncompliance with these rules may lead to serious bodily injuries and even death by electrical shocks or uncontrolled flame formation.
- Repairs concerned with safety elements should be carried out only by the manufacturing company.
- The device should never be used by children, mentally handicapped and inexperienced persons.
- Children must not be allowed to play with the device.
- Keep the device away from explosive and flammable materials.
- Device must intake air, ventilation and air discharge holes must not be closed.



If you sense gas leakage;

- Shut down valves of all gas devices.
- Open all doors and windows.
- Do not turn on electric devices or do not turn them off if they are working.
- Do not use burner derived tools such as match and lighter.
- Inform the gas company.



Do not store any inflammable materials in boiler room.



Wear hearing protectors if there is noise in boiler room.



In case of fire or other emergency;

- Switch off the main switch
- Close the main fuel shut-off valve outside the plant.
- Take appropriate actions



The burner installation must be carried out in accordance with the instructions. Vibration can damage the burner and its components.



Keep boiler doors closed while starting burner and during burner operation.



Check combustion values to be correct by using flue gas analyzer at the whole adjustment range between minimum, full load, and ignition load.



Use lifting device or belt for lifting fan motor, if necessary



During the first commissioning of the burner or in case of any revision carried out in the electrical system or motor cables by any reason, direction of the fan rotation must certainly be checked by the authorized technical service.



For products that have not been commissioned or started more than 6 months, before activating the servomotor;

In gas and air dampers, servomotor and air damper connections must be checked to ensure that they are free running in spite of immobility and oil freezing.



BURNER ROOM

Install the burner in a suitable room/floor with minimum external air openings and sufficient to ensure perfect combustion, in compliance with current regulations.

Never obstruct air openings of the burner room, burner fan intake vents or air ducts in order to prevent:

- a. The build up of toxic / explosive gas mixtures in the burner room,
- b. Combustion with insufficient air, resulting in hazardous, anti-economical and polluting operation.

The burner must be always protected from rain, snow and frost to prevent corrosion and paint deformations.

Keep the burner room clean and free of solid volatile substances, which could be sucked into the fan and clog the internal burner or combustion head air ducts.

2. TERMS OF WARRANTY

Main and auxiliary equipment and all components used in Ecostar gas burners are guaranteed for 1 year by TERMO ISI SİST. A.Ş starting from the date of commissioning under the maintenance, adjustment, operating conditions and relevant mechanic, chemical and thermal effects explained herein.



Please note that this warranty is only valid if the device(s) is commissioned and maintained by our authorized services.



Our company reserves the right to make any modifications on the product and all instructions thereof for improvement purposes.

2.1.Out of Warranty Conditions

- Any damage arising out of or in relation to customers' non-compliance to their responsibilities with regards to installation, commissioning, operation and maintenance,
- Any damage arising out of or in relation to commissioning, repairs and maintenance carried out by unauthorized services,
- Any damage that may occur during transportation or storage of the product,
- Not preserving the product in its original packaging until the installation stage,
- Incorrect and poor electrical connections, Failures due to incorrect voltage applications, frequent repetition of voltage fluctuations,
- Any damage that may occur as a result of incorrect fuel usage or, foreign substances in the fuel used or using of the product without any fuel,
- Any damage that may occur due to foreign particles entered into the product during installation and operation,
- Failures due to incorrect device selection,
- Any damage to unit due to natural disasters,
- Devices without any warranty certificates,
- Warranty Certificates without the stamp and signature of the authorized dealer or service,
- Devices with any falsification on the warranty certificate or without an original serial number.
- The risks during transportation of device under the responsibility of customer belong to the customer.
- Presence of misuse faults are indicated in the reports issued by authorized service stations or our authorized agent, dealer, representative or our factory in case of unavailability of authorized service stations.
- Customers may apply consumer protection arbitrator committee with regards to this report and request for an expert report.

3. BURNER'S GENERAL FEATURES

ECOSTAR gas burners are manufactured such that they operate in gas pressure of min. 20 mbar and max. 300 mbar., at 15%...+10% of nominal voltage, between the ambient temperature range of -15°C...+60°C and declared capacity and boiler pressure ranges with Natural Gas and Liquid Petrol Gas.

3.1.Purpose of Use and Work Limits of Burners

- This product works at any load value equivalent to its max. capacity or covered by its capacity range;
 - In hot water and steam boilers,
 - In direct and indirect hot air generators,
 - Industrial appliances operating at temperature below 600 °C,
 - -15 °C...+60 °C ambient temperature range,
 - 1N 230 VAC/3N 380VAC /50 Hz feed voltage (-%15...+%10) values,
 - Max. 95% relative humidity,
 - In well-ventilated open and closed spaces compatible with protection class IP 40.
 - Operation with Natural gas and LPG.



This device must never be operated with open flame!

3.2.Code Key

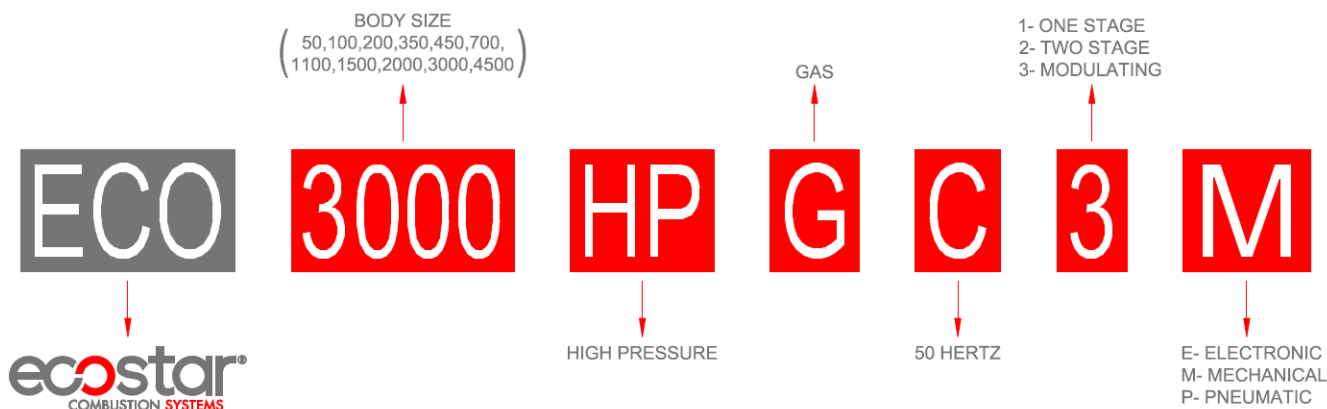

3.3. Burner Components

ECO 50 HP G

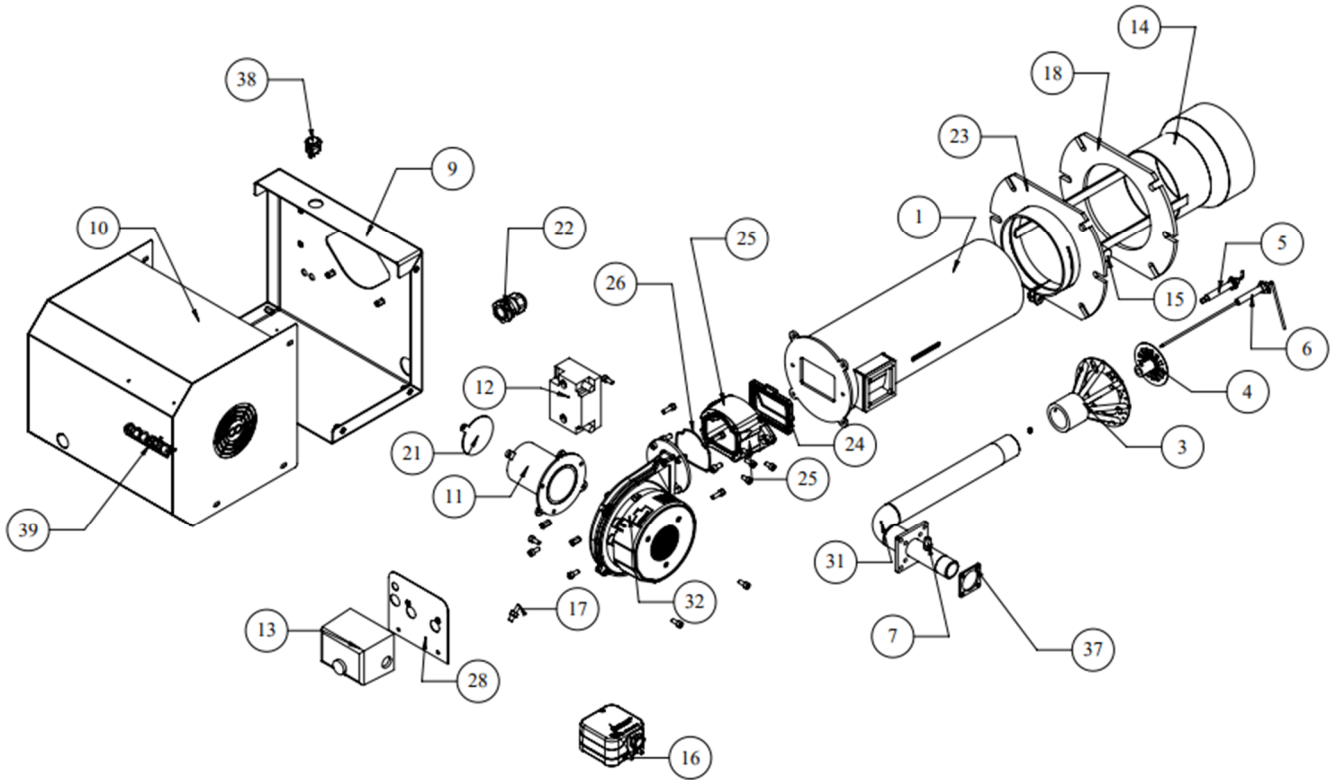

NO.	PART NUMBER	TANIM	DESCRIPTION	PIECES
1	5001360210080	ALEV BORUSU	FLAME PIPE	1
2	5000380210018	GAZ GİRİŞ BORUSU	GAS INLET PIPE	1
3	200135020004	GAZ KAFASI	GAS HEAD	1
4	1 135 020 0001	TURBULATOR	TURBULATOR	1
5	200133010020	ELEKT.ATEŞ.	ELECTRODE IGNITION	1
6	200133010032	ELEKT.İYON.	ELECTRODE IONIZATION	1
7	200058010001	PURJÖR	PURGER	1
9	5001530210035	ÖN KAPAK SACI	FRONT COVER SHEET	1
10	5001530210032	ARKA KAPAK	BACK COVER	1
11	5000440210004	KLAPE BORUSU	CLAMP PIPE	1
12	2 022 075 0001	ATEŞLEME TRAFOSU	IGNITION TRANSFORMER	1
13	2 021 062 0010	ROLE	RELAY	1
14	5001360210081	A.BORU UZATMASI	FLAME PIPE EXTENSION	1
15	200064010031	CIVATA	BOLT	2
16	200023010013	PRESOSTAT	AIR SWITCH	1
17	2 058 491 0001	PRESOSTAT PURJÖRÜ	AIR SWITCH PURGER	1
18	200056010138	CONTA	GASKET	1
21	5000440200034	KLAPE SACI	CLAMP SHEET	1
22	2 092 281 0001	RAKOR	RAKOR	1
23	5001060210004	BAĞLANTI FLANŞI	CONNECTION FLANGE	1
24	5000440100047	GERİ TEPME KLAPESİ	RECYCLE CLAMP	1
25	5 106 127 0001	KLAPE ARA PARÇA	CLAMP SPACER	1
26	200056010528	ORING Ø62 * 2 MM	ORING Ø62 * 2 MM	1
28	5001530210036	RÖLE BAĞ. SACI	RELAY CONNECTION SHEET	1
31	5000380200009	GAZ GİRİŞ BORUSU	GAS INLET PIPE	1
32	200095010071	FAN	FAN	1
33	200119010242	GAZ VENTİLİ	GAS VALVE	2
34	200069010002	NİPEL 3/4 SİYAH K.	NİPEL 3/4 BLACK K.	1
35	200070010010	NİPEL 1/2" -3/4"ODZN	NİPEL 1/2" -3/4"ODZN	1
36	200026010204	GAZ REGULATOR	GAS REGULATOR	1
37	200056020008	GAZ BORUSU CONTASI	GAS PIPE GASKET	1
38	200085010107	ANAHTAR TEKLİ	SINGLE SWITCH	1
39	5000570500002	ETİKET	LABEL	1

ECO 100 HP G

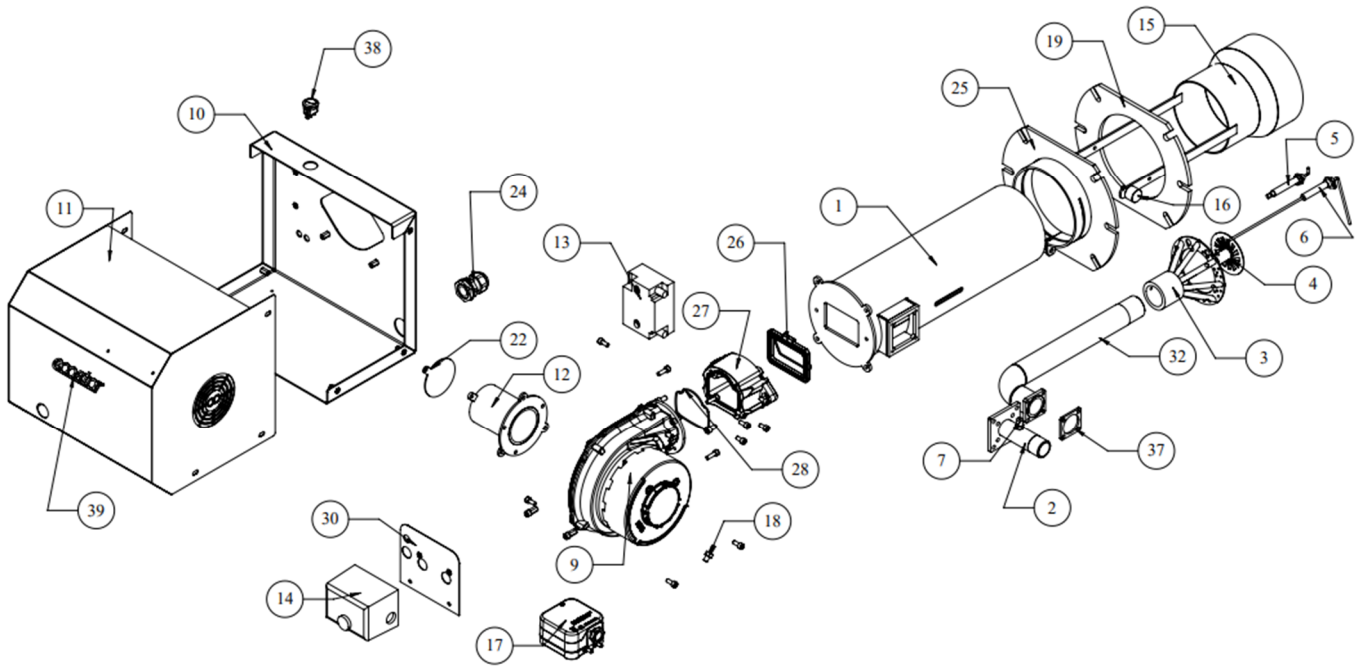

NO.	PART NUMBER	TANIM	DESCRIPTION	PIECES
1	5001360210080	ALEV BORUSU	FLAME PIPE	1
2	5000380210018	GAZ GİRİŞ BORUSU	GAS INLET PIPE	1
3	200135020004	GAZ KAFASI	GAS HEAD	1
4	1 135 020 0001	TURBULATOR	TURBULATOR	1
5	200133010020	ELEKTROT ATEŞLEME	ELECTRODE IGNITION	1
6	200133010032	ELEKT.İYON.	ELECTRODE IONIZATION	1
7	200058010001	PURJÖR	PURGER	1
9	200095010074	FAN	FAN	1
10	5001530210035	ÖN KAPAK SACI	FRONT COVER SHEET	1
11	5001530210032	ARKA KAPAK	BACK COVER	1
12	5000440210004	KLAPE BORUSU	CLAMP PIPE	1
13	2 022 075 0001	ATEŞLEME TRAFOSU	IGNITION TRANSFORMER	1
14	2 021 062 0010	ROLE	RELAY	1
15	5001360210081	A.BORU UZATMASI	FLAME PIPE EXTENSION	1
16	200064010031	CIVATA	BOLT	2
17	200023010013	PRESOSTAT	AIR SWITCH	1
18	2 058 491 0001	PRESOSTAT PURJÖRÜ	AIR SWITCH PURGER	1
19	200056010138	CONTA	GASKET	1
22	5000440200034	KLAPE SACI	CLAMP SHEET	1
24	2 092 281 0001	RAKOR	RAKOR	1
25	5001060210004	KAZAN BAĞ. FLANŞI	BOILER CONNECTION FLANGE	1
26	5000440100047	GERİ TEPME KLAPESİ	RECYCLE CLAMP	1
27	5 106 127 0001	KLAPE ARA PARÇA	CLAMP SPACER	1
28	200056010528	ORING Ø62 * 2 MM	ORING Ø62 * 2 MM	1
30	5001530210036	RÖLE BAĞ. SACI	RELAY CONNECTION SHEET	1
32	5000380200009	GAZ GİRİŞ BORUSU	GAS INLET PIPE	1
33	200119010242	GAZ VENTİLİ	GAS VALVE	2
34	200069010002	NİPEL 3/4 SİYAH K.	NIPPEL 3/4 BLACK K.	1
35	200070010010	NİPEL 1/2" -3/4"ODZN	NİPEL 1/2" -3/4"ODZN	1
36	200026010204	GAZ REGULATOR	GAS REGULATOR	1
37	200056020008	GAZ BORUSU CONTASI	GAS PIPE GASKET	1
38	200085010107	ANAHTAR TEKLİ	SINGLE SWITCH	1
39	5000570500002	ETİKET	LABEL	1

ECO 200 HP G

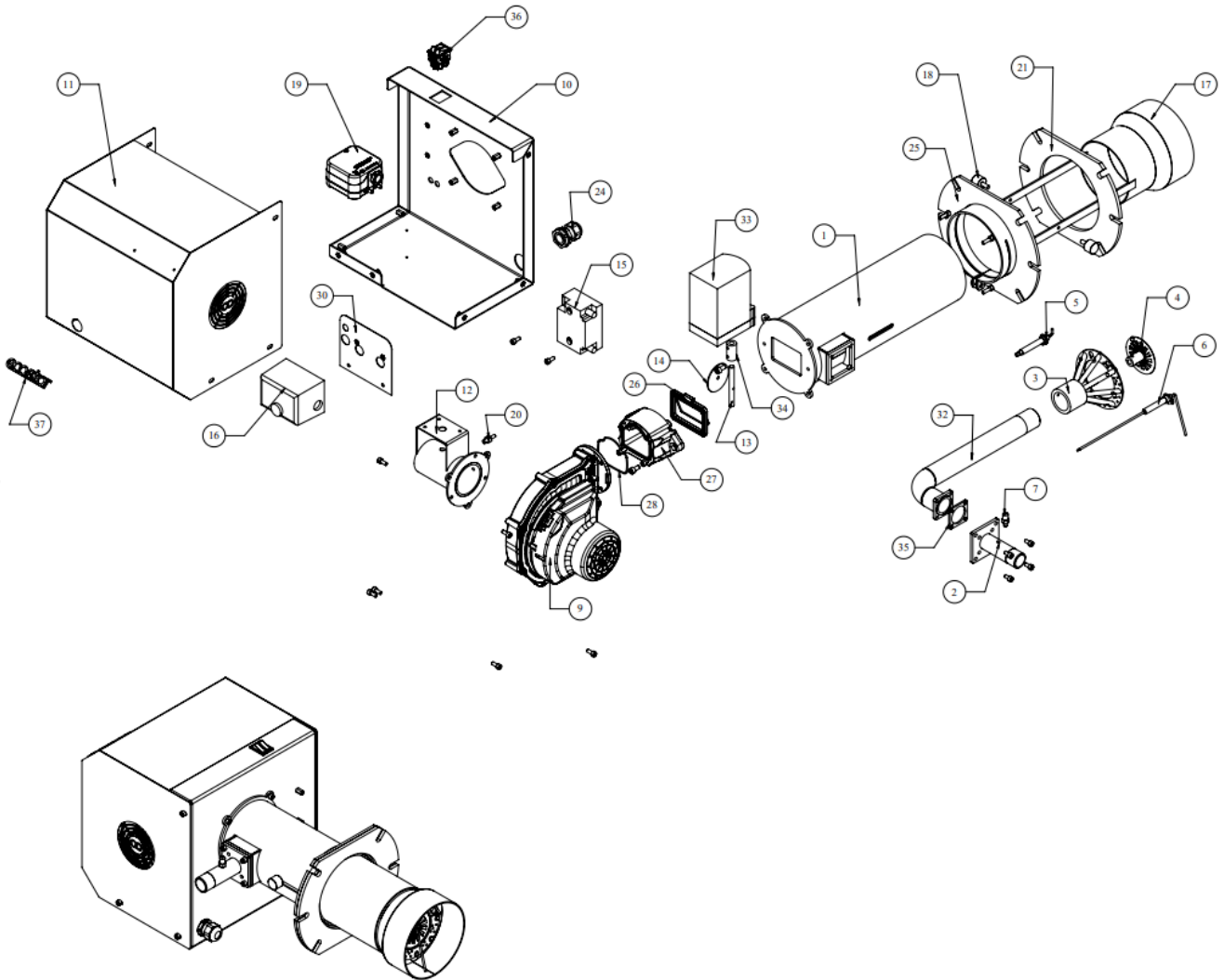

NO.	PART NUMBER	TANIM	DESCRIPTION	PIECES
1	5001360210080	ALEV BORUSU	FLAME PIPE	1
2	5000380210018	GAZ GİRİŞ BORUSU	GAS INLET PIPE	1
3	200135020004	GAZ KAFASI	GAS HEAD	1
4	1 135 020 0001	TURBULATOR	TURBULATOR	1
5	200133010020	ELEKTROT ATEŞLEME	ELECTRODE IGNITION	1
6	200133010032	ELEKT.İYON	ELECTRODE IONIZATION	1
7	200058010001	PURJÖR	PURGER	1
9	200095010120	FAN	FAN	1
10	5001530210039	ÖN KAPAK SACI	FRONT COVER SHEET	1
11	5001530210040	ARKA KAPAK SACI	BACK COVER SHEET	1
12	5000440210006	KLAPE BORUSU	CLAMP PIPE	1
13	5000440200035	KLAPE MILI	CLAMP SHAFT	1
14	5000440210007	KLAPE SACI	CLAMP SHEET	1
15	2 022 075 0001	ATEŞLEME TRAFOSU	IGNITION TRANSFORMER	1
16	2 021 062 0010	ROLE	RELAY	1
17	5001360210081	ALEV BORU UZATMASI	FLAME PIPE EXTENSION	1
18	200064010031	CIVATA	BOLT	2
19	200023010013	PRESOSTAT	AIR SWITCH	1
20	2 058 491 0001	PRESOSTAT PURJÖRÜ	AIR SWITCH PURGER	1
21	200056010138	CONTA	GASKET	1
24	2 092 281 0001	RAKOR	RAKOR	1
25	5001060210004	KAZAN BAĞ. FLANŞI	BOILER CONNECTION FLANGE	1
26	5000440100047	GERİ TEPME KLAPESİ	RECYCLE CLAMP	1
27	5 106 127 0001	KLAPE ARA PARÇA	CLAMP SPACER	1
28	200056010528	ORING Ø62 * 2 MM	ORING Ø62 * 2 MM	1
30	5001530210036	RÖLE BAĞ. SACI	RELAY CONNECTION SHEET	1
32	5000380200009	GAZ GİRİŞ BORUSU	GAS INLET PIPE	1
33	200025010094	SERVOMOTOR	AIR DAMPER (SERVOMOTOR)	1
34	200043010021	SERVOMOTOR KAPLINI	SERVOMOTOR COUPLING	1
35	200056020008	GAZ BORUSU CONTASI	GAS PIPE GASKET	1
36	200085010109	ANAHTAR ÇİFTLİ	DOUBLE SWITCH	1
37	5000570500002	ETİKET	LABEL	1

ECO 350 HP G

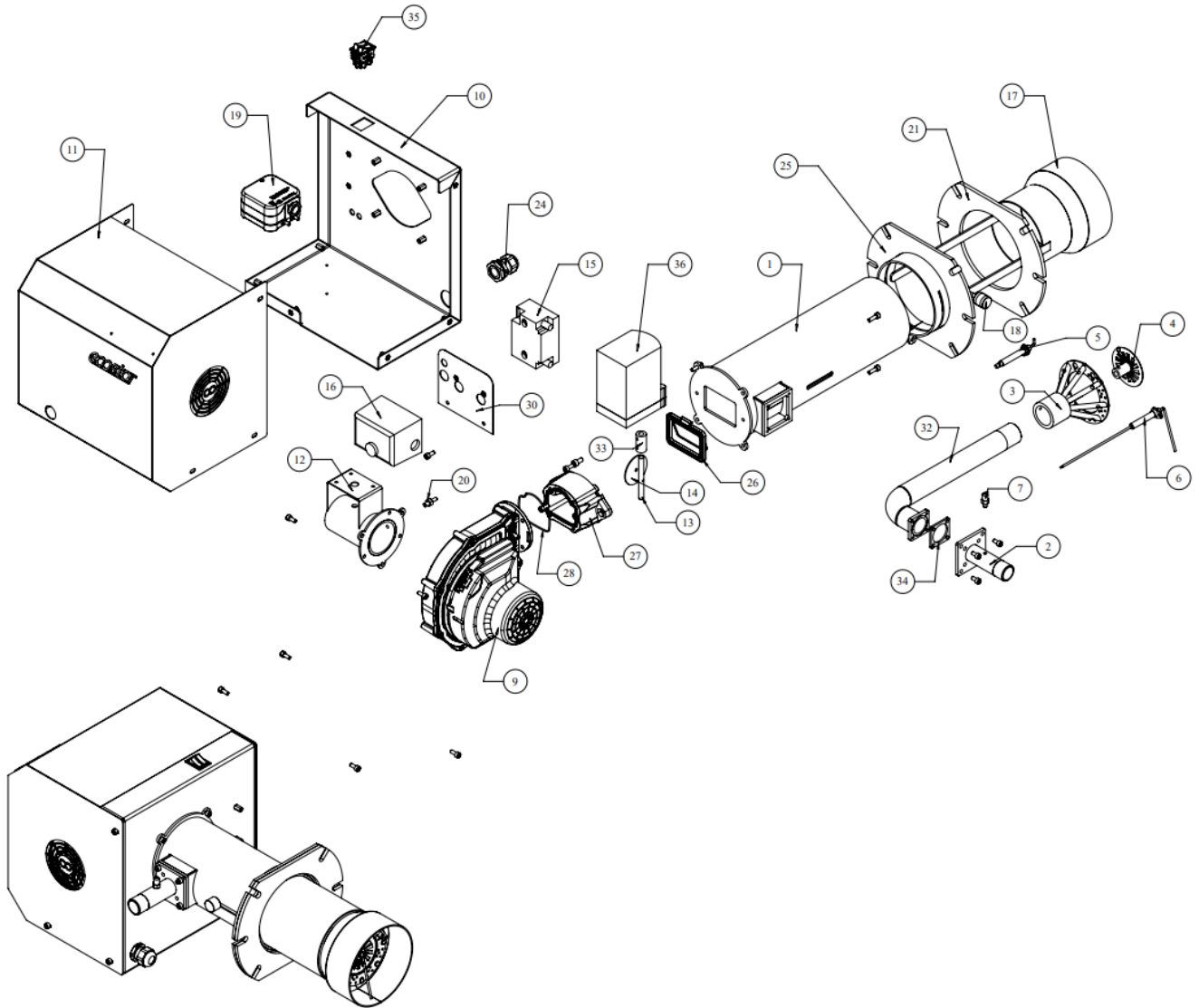

NO.	PART NUMBER	TANIM	DESCRIPTION	PIECES
1	5001360210080	ALEV BORUSU	FLAME PIPE	1
2	5000380210018	GAZ GİRİŞ BORUSU	GAS INLET PIPE	1
3	200135020004	GAZ KAFASI	GAS HEAD	1
4	1 135 020 0001	TURBULATOR	TURBULATOR	1
5	200133010020	ELEKT.ATEŞLEME	ELECTRODE IGNITION	1
6	200133010032	ELEKT.İYON	ELECTRODE IONIZATION	1
7	200058010001	PURJÖR	PURGER	1
9	200095010120	FAN	FAN	1
10	5001530210039	ÖN KAPAK SACI	FRONT COVER SHEET	1
11	5001530210040	ARKA KAPAK SACI	BACK COVER SHEET	1
12	5000440210006	KLAPE BORUSU	CLAMP PIPE	1
13	5000440200035	KLAPE MILI	CLAMP SHAFT	1
14	5000440210007	KLAPE SACI	CLAMP SHEET	1
15	2 022 075 0001	ATEŞLEME TRAFOSU	IGNITION TRANSFORMER	1
16	2 021 062 0010	ROLE	RELAY	1
17	5001360210081	ALEV BORU UZATMASI	FLAME PIPE EXTENSION	1
18	200064010031	CIVATA	BOLT	2
19	200023010013	PRESOSTAT	AIR SWITCH	1
20	2 058 491 0001	PRESOSTAT PURJÖRÜ	AIR SWITCH PURGER	1
21	200056010138	CONTA	GASKET	1
24	2 092 281 0001	RAKOR	RAKOR	1
25	5001060210004	KAZAN BAĞ. FLANŞI	BOILER CONNECTION FLANGE	1
26	5000440100047	GERİ TEPME KLAPESİ	RECYCLE CLAMP	1
27	5 106 127 0001	KLAPE ARA PARÇA	CLAMP SPACER	1
28	200056010528	ORING Ø62 * 2 MM	ORING Ø62 * 2 MM	1
30	5001530210036	RÖLE BAĞ. SACI	RELAY CONNECTION SHEET	1
32	5000380200009	GAZ GİRİŞ BORUSU	GAS INLET PIPE	1
33	200043010021	SERVOMOTOR KAPLINI	SERVOMOTOR COUPLING	1
34	200056020008	GAZ BORUSU CONTASI	GAS PIPE GASKET	1
35	200085010109	ANAHTAR ÇİFTLİ	DOUBLE SWITCH	1
36	200025010094	SERVOMOTOR	AIR DAMPER (SERVOMOTOR)	1
37	5000570500002	ETİKET	LABEL	1

ECO 450 HP G

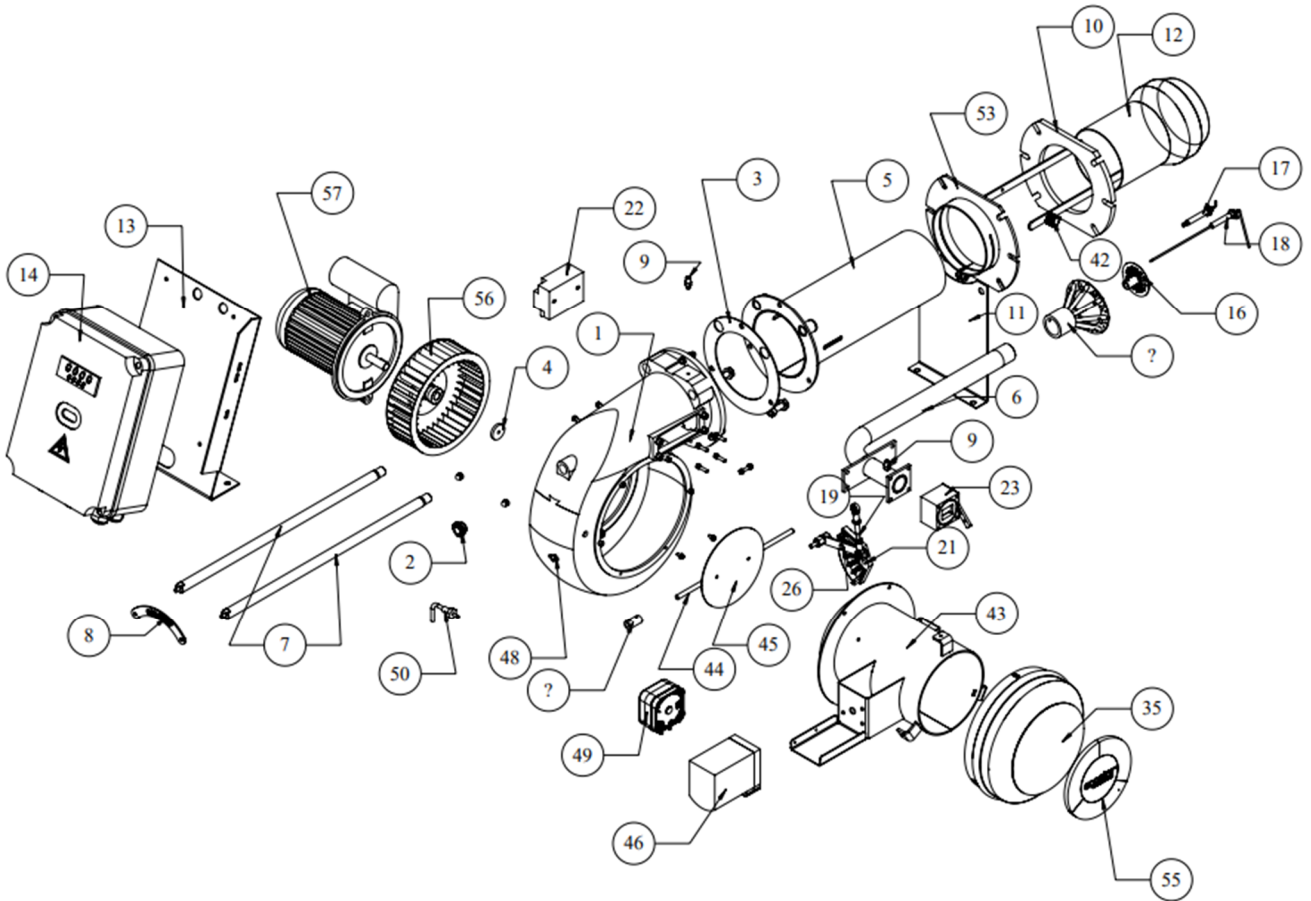

NO.	PART NUMBER	TANIM	DESCRIPTION	PIECES
1	5001010200047	GÖVDE	BODY	1
2	200060010003	GÖZETLEME CAMI	OBSERVATION GLASS	1
3	200056010206	KLİNGRİT CONTA	GASKET	1
4	5000670100005	MOTOR EMNİYET PULU	MOTOR SECURITY ROVE	1
5	200136020095	ALEV BORUSU	FLAME PIPE	1
6	200038010061	GAZ GİRİŞ BORUSU	GAS INLET PIPE	1
7	2 049 114 1301	TASIMA MILİ	HANDLING SHAFT	2
8	2 049 116 1111	MİL SABİTLEME PLAKASI	SHAFT FIXING PLATE	1
9	200058010001	PURJÖR	PURGER	2
10	200056010673	KAZAN BAĞLANTI CONTASI	BOILER CONNECTION GASKET	1
11	5000540100045	DESTEK AYAĞI	SUPPORT FEET	1
12	5001360210083	A.BORU UZATMASI	FLAME PIPE EXTENSION	1
13	5000530100171	PANO BAĞ SACI	PANEL CONNECTION SHEET	1
14	58101010301030009	PANO	ELECTRICAL PANEL	1
15	200135020004	GAZ KAFASI	GAS HEAD	1
16	1 135 020 0001	TURBULATOR	TURBULATOR	1
17	200133010020	ELEKT.ATEŞ.	ELECTRODE IGNITION	1
18	200133010032	ELEKT.İYON.	ELECTRODE IONIZATION	1
19	5000440200038	ORANSAL DİSK HAREKET KOLU	PROPORTIONAL DISC MOVEMENT LEVER	1
20	2 059 056 0001	KÜRESEL MAFSAL	BALL JOINT	2
21	200097010037	DİSK GRUBU ORANSAL	DISC GROUP PROPORTIONAL	1
22	2 022 075 0001	ATEŞLEME TRAFOSU	IGNITION TRANSFORMER	1
23	200020010007	VANA GAZ AYAR	VALVE GAS ADJUSTMENT	1
24	200068010030	PİM	GIB	1
25	200068010042	SEGMAN	RING	1
26	5000440200041	HAREKET KOLU ORANSAL	LEVER PROPORTIONAL	1
42	200064010031	CIVATA	BOLT	2
43	5001030210015	HAVA KAFESİ	AIR CAGE	1
44	5000440200037	KLAPE MİLİ	CLAMP SHAFT	1
45	5000440200036	KLAPE SACI	CLAMP SHEET	1
46	200025010090	SERVOMOTOR	AIR DAMPER (SERVOMOTOR)	1
47	200043010021	SERVOMOTOR KAPLINI	SERVOMOTOR COUPLING	1
48	2 058 491 0001	PRESOSTAT PURJÖRÜ	AIR SWITCH PURGER	1
49	200023010013	PRESOSTAT	AIR SWITCH	1
50	200058010007	PRES.ADAPTÖR	AIR SWITCH ADAPTER	1
53	5001060210005	KAZAN BAĞ. FLANŞI	BOILER CONNECTION FLANGE	1
54	5001030210032	SUSTURUCU	SILENCER	1
55	3000370018	ETİKET	LABEL	1
56	200116020037	FAN	FAN	1
57	200115020037	MOTOR	MOTOR	1

ECO 700 HP G

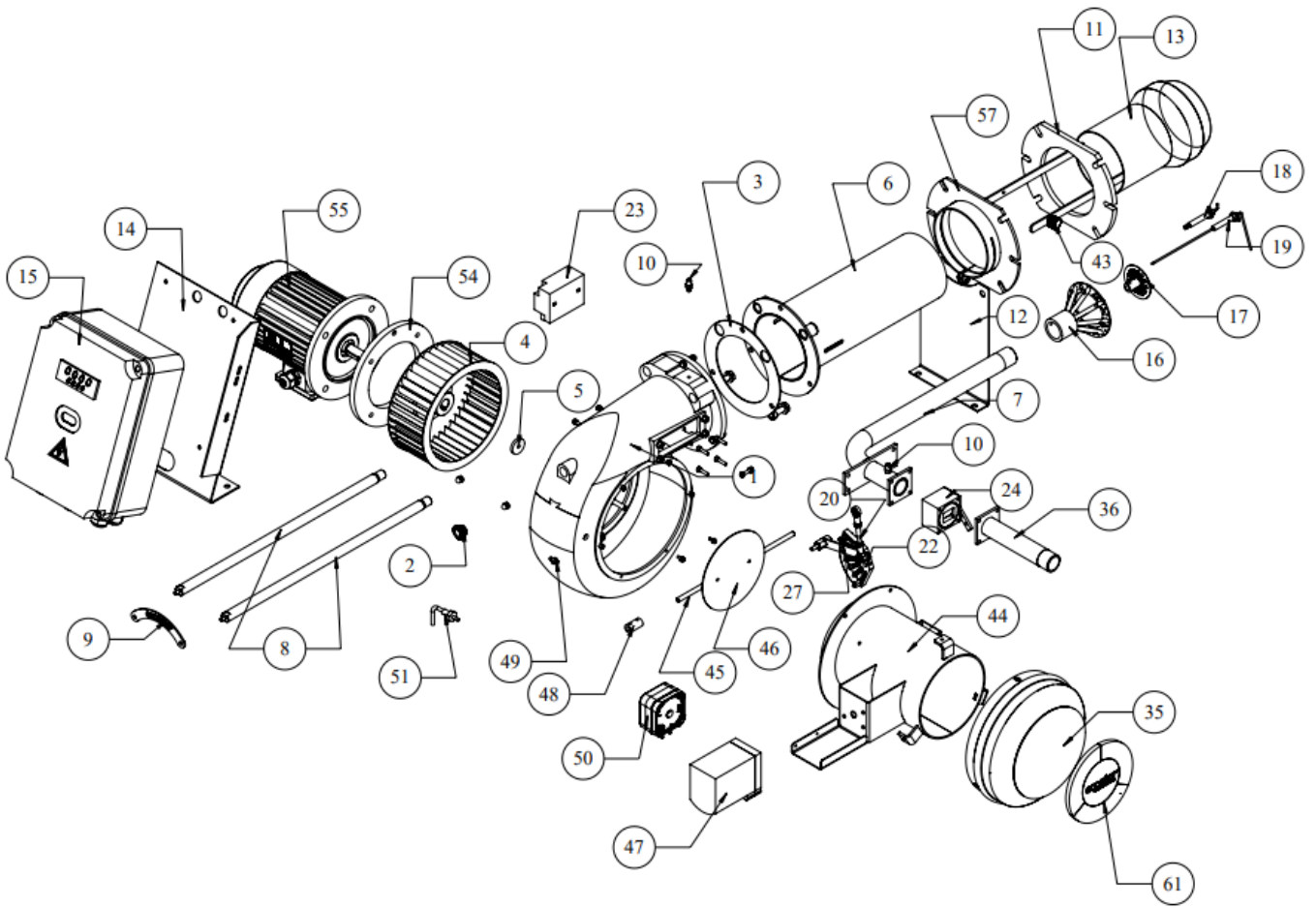

NO.	PART NUMBER	TANIM	DESCRIPTION	PIECES
1	5001010200047	GÖVDE	BODY	1
2	200060010003	GÖZETLEME CAMI	OBSERVATION GLASS	1
3	200056010206	KLİNGRİT CONTA	GASKET	1
4	200116020043	FAN	FAN	1
5	5000670100005	MOTOR EMNİYET PULU	MOTOR SECURITY ROVE	1
6	200136020095	ALEV BORUSU	FLAME PIPE	1
7	200038010061	GAZ GİRİŞ BORUSU	GAS INLET PIPE	1
8	2 049 114 1301	TASIMA MILİ	HANDLING SHAFT	2
9	2 049 116 1111	MİL SABİTLEME PLAKASI	SHAFT FIXING PLATE	1
10	200058010001	PURJÖR	PURGER	2
11	200056010673	KAZAN BAĞLANTI CONTASI	BOILER CONNECTION GASKET	1
12	5000540100045	DESTEK AYAĞI	SUPPORT FEET	1
13	5001360210083	A.BORU UZATMASI	FLAME PIPE EXTENSION	1
14	5000530100171	PANO BAĞ SACI	PANEL CONNECTION SHEET	1
15	58101010301030011	PANO	ELECTRICAL PANEL	1
16	200135020004	GAZ KAFASI	GAS HEAD	1
17	1 135 020 0001	TURBULATOR	TURBULATOR	1
18	200133010020	ELEKT.ATEŞ.	ELECTRODE IGNITION	1
19	200133010032	ELEKT.İYON.	ELECTRODE IONIZATION	1
20	5000440200038	ORANSAL DİSK HAREKET KOLU	PROPORTIONAL DISC MOVEMENT LEVER	1
21	2 059 056 0001	KÜRESEL MAFSAL	BALL JOINT	2
22	200097010037	DİSK GRUBU ORANSAL	DISC GROUP PROPORTIONAL	1
23	2 022 075 0001	ATEŞLEME TRAFOSU	IGNITION TRANSFORMER	1
24	200020010007	VANA GAZ AYAR	VALVE GAS ADJUSTMENT	1
25	200068010030	PİM	GIB	1
26	200068010042	SEGMAN	RING	1
27	5000440200041	HAREKET KOLU ORANSAL	LEVER PROPORTIONAL	1
43	200064010031	CIVATA	BOLT	2
44	5001030210015	HAVA KAFESİ	AIR CAGE	1
45	5000440200037	KLAPE MİLİ	CLAMP SHAFT	1
46	5000440200036	KLAPE SACI	CLAMP SHEET	1
47	200025010090	SERVOMOTOR	AIR DAMPER (SERVOMOTOR)	1
48	200043010021	SERVOMOTOR KAPLINI	SERVOMOTOR COUPLING	1
49	2 058 491 0001	PRESOSTAT PURJÖRÜ	AIR SWITCH PURGER	1
50	200023010013	PRESOSTAT	AIR SWITCH	1
51	200058010007	PRES.ADAPTÖR	AIR SWITCH ADAPTER	1
54	5001040200003	MOTOR BAĞ.FLANŞI	MOTOR CONNECTION FLANGE	1
55	200115020092	MOTOR	MOTOR	1
57	5001060210005	KAZAN BAĞ. FLANŞI	BOILER CONNECTION FLANGE	1
58	5001030210032	SUSTURUCU	SILENCER	1
59	5005020210002	VENTİL UZATMA BORUSU	VALVE EXTENSION PIPE	1
61	3000370018	ETİKET	LABEL	1

ECO 1100 HP G

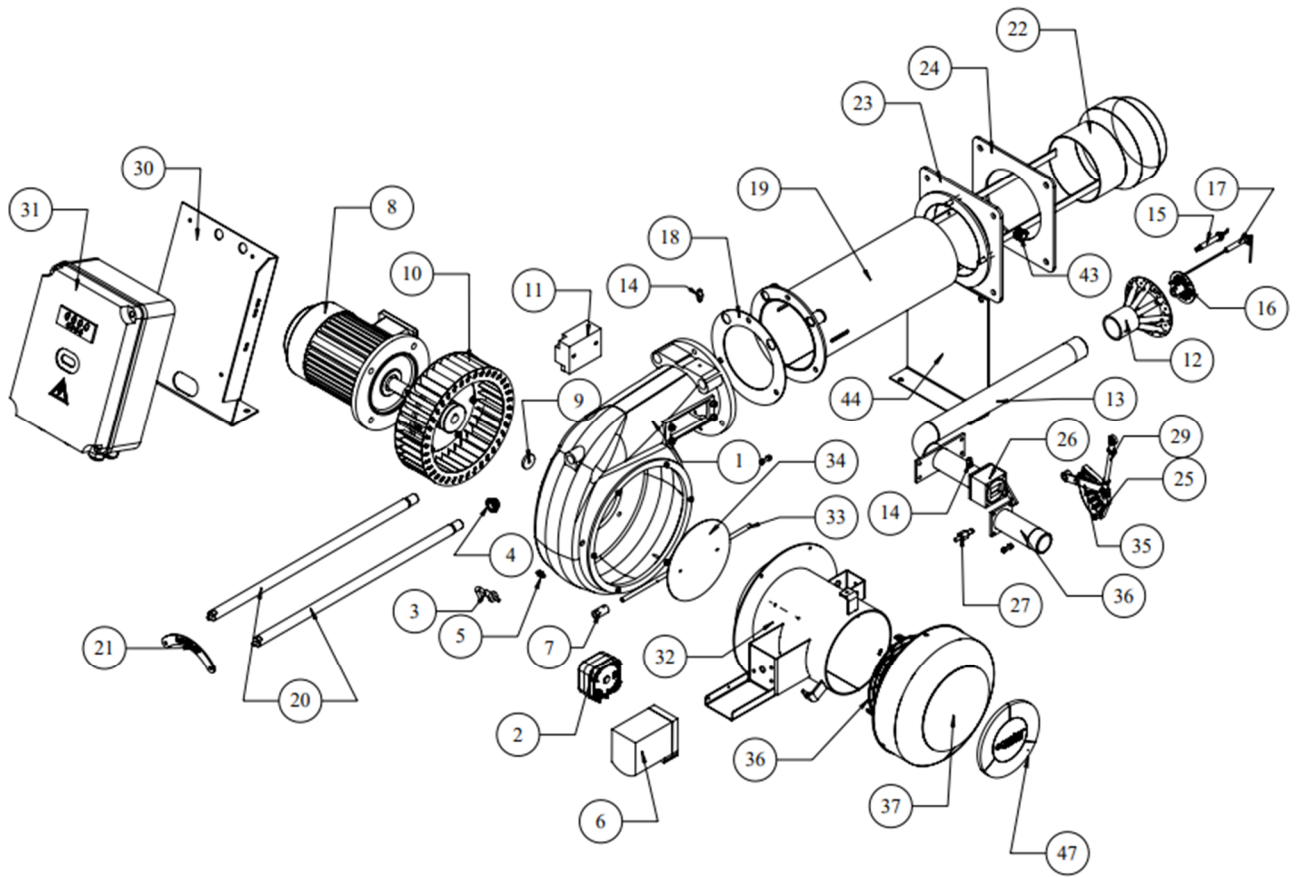

NO.	PART NUMBER	TANIM	DESCRIPTION	PIECES
1	5001010200048	GÖVDE GRUBU	BODY	1
2	200023010013	PRESOSTAT	AIR SWITCH	1
3	200058010007	PRES.ADAPTÖR	AIR SWITCH ADAPTER	1
4	200060010003	GÖZETLEME CAMI	OBSERVATION GLASS	1
5	2 058 491 0001	PRESOSTAT PURJÖRÜ	AIR SWITCH PURGER	1
6	200025010090	SERVOMOTOR	AIR DAMPER (SERVOMOTOR)	1
7	200043010021	SERVOMOTOR KAPLINI	SERVOMOTOR COUPLING	1
8	200115020100	MOTOR	MOTOR	1
9	5000670100005	MOTOR EMNİYET PULU	MOTOR SECURITY ROVE	1
10	200116020050	FAN	FAN	1
11	2 022 075 0001	ATEŞLEME TRAFOSU	IGNITION TRANSFORMER	1
12	1 135 145 0001	GAZ KAFASI	GAS HEAD	1
13	5000380200006	GAZ GIRIS BOR.	GAS INLET PIPE	1
14	200058010001	PURJÖR	PURGER	2
15	200133010020	ELEKT.ATEŞ.	ELECTRODE IGNITION	1
16	1 135 020 0001	TURBULATOR	TURBULATOR	1
17	200133010032	ELEKT.İYON.	ELECTRODE IONIZATION	1
18	200056010203	KLİNGRİT CONTA	KLINGRITE GASKET	1
19	200136020104	ALEV BORUSU	FLAME PIPE	1
20	2 049 117 1145	TASIMA MILİ	HANDLING SHAFT	2
21	2 049 118 1101	MİL SABİTLEME PLAKASI	SHAFT FIXING PLATE	1
22	5001360210087	A.BORU UZATMASI	FLAME PIPE EXTENSION	1
23	5001060200014	KAZAN B.FLANŞI	BOILER CONNECTION FLANGE	1
24	200056010139	CONTA	GASKET	1
25	200097010037	DİSK GRUBU ORANSAL	DISC GROUP PROPORTIONAL	1
26	200020010007	VANA GAZ AYAR	VALVE GAS ADJUSTMEN	1
27	200068010030	PİM	GIB	1
28	2 059 056 0001	MAFSAL KURESEL M6-PHS 6A	BALL JOINT	2
29	5000440200047	ORANSAL DİSK HAREKET KOLU	PROPORTIONAL DISC MOVEMENT LEVER	1
30	5000530100171	PANO BAĞ SACI	PANEL CONNECTION SHEET	1
31	58101010301030008	PANO	ELECTRICAL PANEL	1
32	5001030210019	HAVA KAFESİ	AIR CAGE	1
33	5000440200045	KLAPE MİLİ	CLAMP SHAFT	1
34	5000440200044	KLAPE SACI	CLAMP SHEET	1
35	5000440200043	HAREKET KOLU ORANSAL	LEVER PROPORTIONAL	1
36	5000440200055	KLAPE MUHAFAZA SACI	FLAP GUARD SHEET	1
43	200064010031	CIVATA	BOLT	2
44	5000540100049	DESTEK AYAĞI	SUPPORT FEET	1
45	5005020210003	G.YOLU BORUSU	GAS LINE PIPE	1
46	200053020011	SUSTURUCU	SILENCER	1
47	3000370018	ETİKET	LABEL	1

ECO 1500 HP G

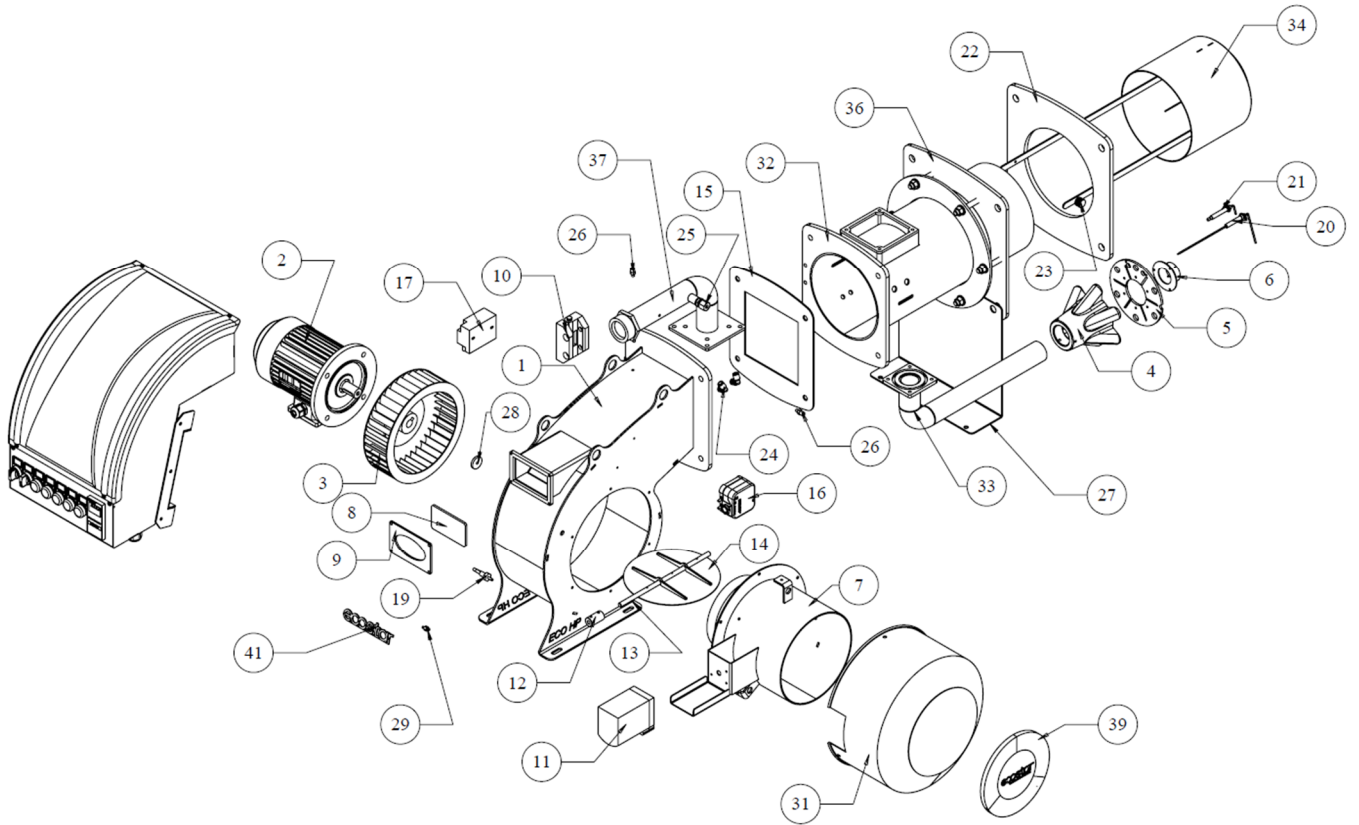

NO.	PART NUMBER	TANIM	DESCRIPTION	PIECES
1	5001020210005	GÖVDE	BODY	1
2	200115020100	MOTOR	MOTOR	1
3	200116020068	FAN	FAN	1
4	5001350200006	GAZ KAFASI	GAS HEAD	1
5	5001340200013	TÜRBÜLATÖR	TURBULATOR	1
6	2 053 797 0001	ÖN KAPAK	FRONT COVER	1
7	5001030210020	HAVA KAFESİ	AIR CAGE	1
8	5000600100009	GOZETLEME CAMI	OBSERVATION GLASS	1
9	5000600200001	GÖZETLEME ÇERÇEVESİ	OBSERVATION FRAME	1
10	200049010090	MENTEŞE GRUBU	HINGE GROUP	1
11	200025010093	SERVOMOTOR	AIR DAMPER (SERVOMOTOR)	1
12	200043010074	SERVOMOTOR KAPLINI	SERVOMOTOR COUPLING	1
13	5000440200049	KLAPE MİLİ	CLAMP SHAFT	1
14	5000440210012	KLAPE SACI	CLAMP SHEET	1
15	200056020001	KLINGIRIT CONTA	KLINGRITE GASKET	1
16	200023010013	PRESOSTAT	AIR SWITCH	1
17	2 022 075 0001	ATEŞLEME TRAFOSU	IGNITION TRANSFORMER	1
18	5000530200051	MENTEŞE	HINGE	2
19	200058010007	PRES.ADAPTÖR	AIR SWITCH ADAPTER	1
20	200133010033	İYONİZASYON ELEKTRODU	IONIZATION ELECTRODE	1
21	200133010020	ELEKT.ATEŞLEME	ELECTRICAL IGNITION	1
22	200056020010	ELYAF CONTA	FIBER GASKET	1
23	200064010031	ALEV BORU UZATMASI CIVATASI	FLAME PIPE EXTENSION SCREW	2
24	200073010121	PNOMATİK DİRSEK	PNEUMATIC ELBOW	2
25	200072010007	RAKOR	RAKOR	1
26	200058010001	PURJÖR	PURGER	2
27	5000540200005	DESTEK SACI	SUPPORT SHEET	1
28	5000670100005	MOTOR EMNİYET PULU	ENGINE SAFETY WASHER	1
29	2 058 491 0001	PRESOSTAT PURJÖRÜ	AIR SWITCH PURGER	1
31	2000530200005	SUSTURUCU	SILENGER	1
32	5001360210109	ALEV BORUSU	FLAME PIPE	1
33	5000380210049	GAZ GİRİŞ BORUSU	GAS INLET PIPE	1
34	5001360210110	ALEV BORUSU UZATMASI	FLAME PIPE EXTENSION	1
35	200056010762	ORİNG 69,22X5,34(4H-260)	ORİNG 69,22X5,34(4H- 260)	1
36	5001060200025	BAGLANTI FLANSI	CONNECTION FLANGE SHEET	1
37	5000380210050	GAZ YOLU BORUSU	GAS LINE PIPE	1
38	200070010253	NİPEL	NIPPEL	1
39	3000370017	ETİKET	LABEL	1
41	5000570200005	ETİKET	LABEL	1

ECO 2000 HP G

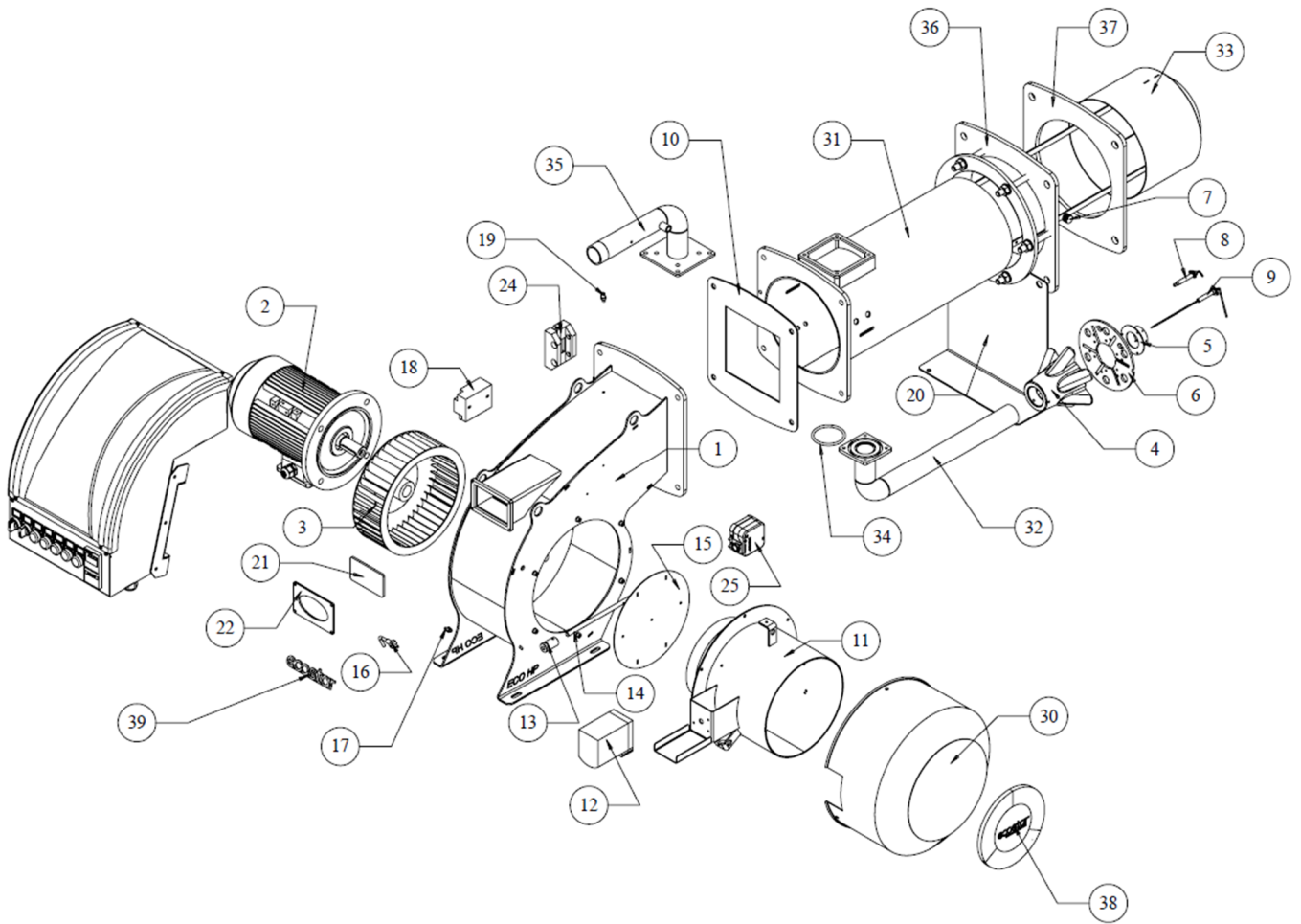

NO.	PART NUMBER	TANIM	DESCRIPTION	PIECES
1	5001020210006	GÖVDE	BODY	1
2	200115020106	MOTOR	MOTOR	1
3	200116010011	FAN	FAN	1
4	5001350200006	GAZ KAFASI	GAS HEAD	1
5	2 053 797 0001	ÖN KAPAK	FRONT COVER	1
6	1 134 998 2000	TURBULATOR	TURBULATOR	1
7	200064010031	ALEV BORU UZATMA CİVATASI	FLAME PIPE EXTENSION SCREW	2
8	200133010020	ELEKT. ATEŞ	ELECTRODE IGNITION	1
9	200133010033	İYONİZASYON ELEKTRODU	IONIZATION ELECTRODE	1
10	200056020002	CONTA	GASKET	1
11	5001030210023	HAVA KAFESİ	AIR CAGE	1
12	200025010093	SERVOMOTOR	AIR DAMPER (SERVOMOTOR)	1
13	200043010074	SERVOMOTOR KAPLİNİ	SERVOMOTOR COUPLING	1
14	5000440200053	KLAPE MİLİ	CLAMP SHAFT	1
15	5000440210011	KLAPE SACI	CLAMP SHEET	1
16	200058010007	PRES. ADAPTÖR	AIR SWITCH ADAPTER	1
17	2 058 491 0001	PRESOSTAT PURJÖRÜ	AIR SWITCH PURGER	1
18	2 022 075 0001	ATEŞLEME TRAFOSU	IGNITION TRANSFORMER	1
19	200058010001	PURJÖR	PURGER	1
20	5000540200006	DESTEK SACI	SUPPORT SHEET	1
21	5000600100009	GOZETLEME CAMI	OBSERVATION GLASS	1
22	5000600200001	GÖZETLEME ÇERÇEVESİ	OBSERVATION FRAME	1
23	5000530200051	MENTEŞE EK	HINGE	2
24	200049010090	MENTEŞE GRUBU	HINGE GROUP	1
25	200023010013	PRESOSTAT	AIR SWITCH	1
30	200053020006	SUSTURUCU	SILENGER	1
31	5001360210111	ALEV BORUSU	FLAME PIPE	1
32	5000380210051	GAZ GİRİŞ BORUSU	GAS INLET PIPE	1
33	5001360210112	ALEV BORUSU UZATMA	FLAME PIPE EXTENSION	1
34	200056010762	ORİNG 69,22X5,34(4H-260)	ORİNG 69,22X5,34(4H-260)	1
35	5000380210050	GAZ YOLU BORUSU	GAS LINE PIPE	1
36	5001060200026	BAĞLANTI FLANSI SAC	CONNECTION FLANGE SHEET	1
37	200056020011	ELYAF CONTA	FIBER GASKET	1
38	3000370017	ETİKET	LABEL	1
39	5000570200005	ETİKET	LABEL	1

ECO 3000 HP G

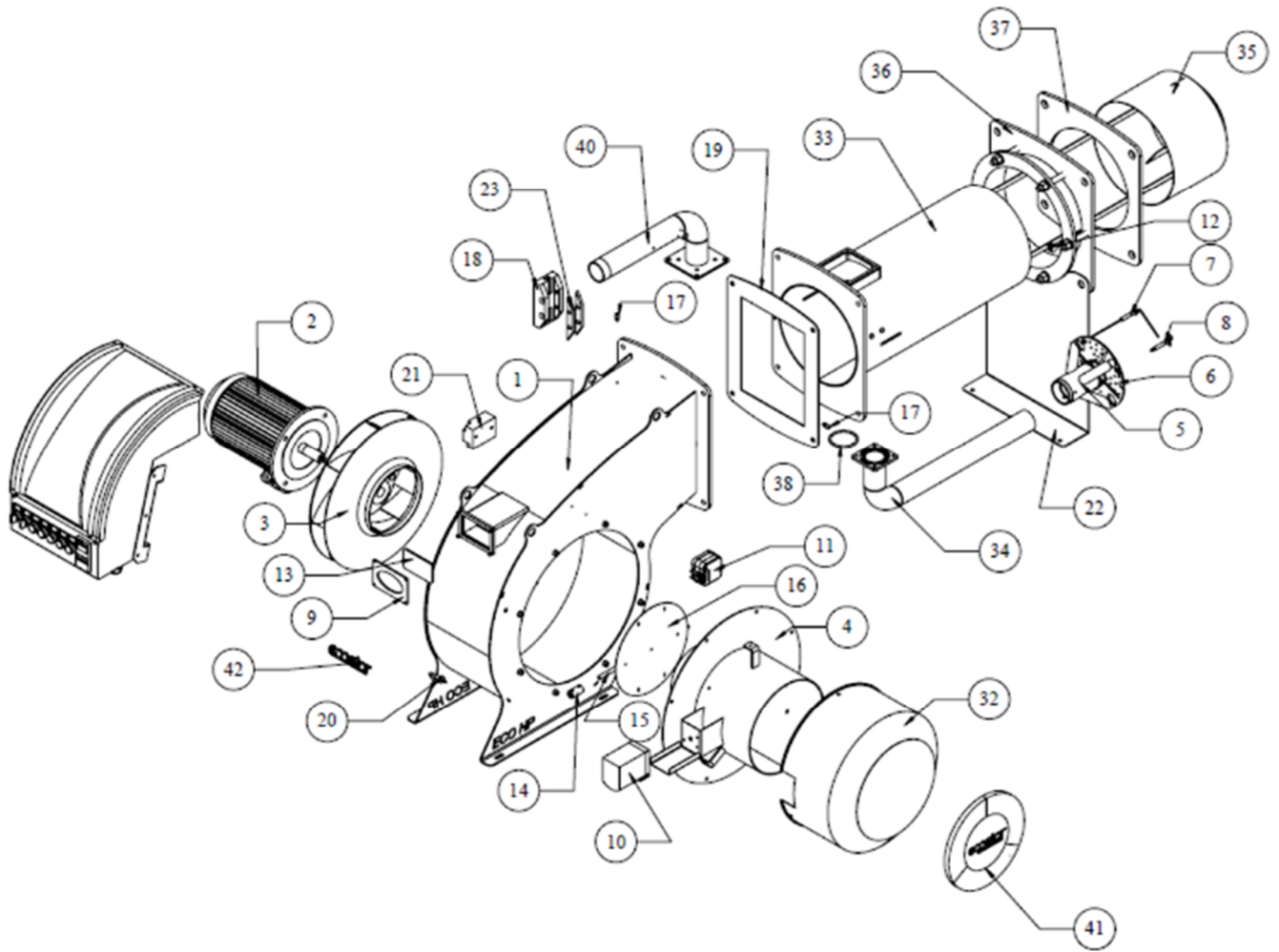

NO.	PART NUMBER	TANIM	DESCRIPTION	PIECES
1	5001020210007	GÖVDE	BODY	1
2	200115020109	MOTOR	MOTOR	1
3	200116020069	FAN	FAN	1
4	5001030210024	HAVA KAFESI	AIR CAGE	1
5	5001350200007	GAZ KAFASI	GAS HEAD	1
6	1 134 998 3000	TURBULATÖR	TURBULATOR	1
7	200133010033	İYONİZASYON ELEKTRODU	IONIZATION ELECTRODE	1
8	200133010020	ELEKT. ATEŞLEME	ELECTRODE IGNITION	1
9	5000600200001	GÖZETLEME CAMI ÇERÇEVESİ	OBSERVATION GLASS FRAME	1
10	200025010093	SERVOMOTOR	AIR DAMPER (SERVOMOTOR)	1
11	200023010013	PRESOSTAT	AIR SWITCH	1
12	200064010031	ALEV BORU UZATMA CIVATI	FLAME PIPE EXTENSION SCREW	2
13	5000600100009	GOZETLEME CAMI	OBSERVATION GLASS	1
14	200043010074	SERVOMOTOR KAPLINTI	SERVOMOTOR COUPLIN	1
15	5000440200039	KLAPE MİLİ	CLAMP SHAFT	1
16	5000440210010	KLAPE SACI	CLAMP SHEET	1
17	200038010001	PURJÖR	PURGER	2
18	200049010092	MENTEŞE GRUBU	HINGE GROUP	1
19	200056020004	KLINGRIT CONTA	KLINGRITE GASKET	1
20	200038010007	PRES. ADAPTÖR	AIR SWITCH ADAPTER	1
21	2 022 075 0001	ATEŞLEME TRAFOSU	IGNITION TRANSFORMER	1
22	5000540200007	DESTEK AYIĞI	SUPPORT FEET	1
23	5000530200054	MENTEŞE	HINGE	2
32	200053020007	SUSTURUCU	SILENGER	1
33	5001360210113	ALEV BORUSU	FLAME PIPE	1
34	5000380210053	GAZ GİRİŞ BORUSU	GAS INLET PIPE	1
35	5001360210114	ALEV BORUSU UZATMASI	FLAME PIPE EXTENSION	1
36	5001060200027	BAĞ FLANŞI	CONNECTION FLANGE SHEET	1
37	200056020012	ELYAF CONTA	FIBER GASKET	1
38	200056010762	ORNG 69,22X3,34(4H-260)	ORNG 69,22X3,34(4H-260)	1
39	200119010220	GAZ VENTİLİ	GAS VALVE	1
40	5000380210055	GAZ YOLU BORUSU	GAS LINE PIPE	1
41	3000370015	ETİKET	LABEL	1
42	5000570200005	ETİKET	LABEL	1

ECO 4500 HP G

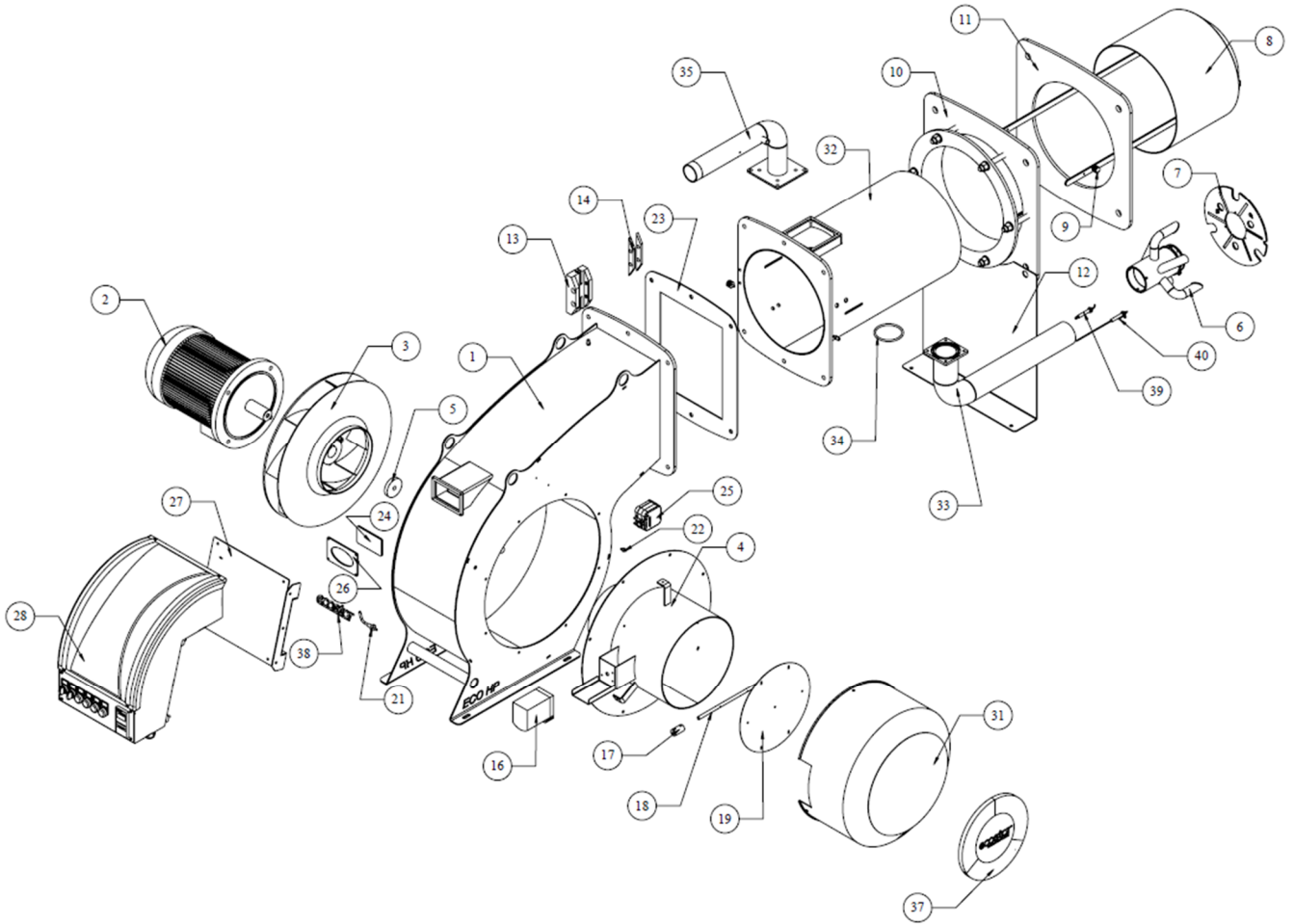

NO.	PART NUMBER	TANIM	DESCRIPTION	PIECES
1	5001020210008	GÖVDE	BODY	1
2	200115020112	MOTOR	MOTOR	1
3	200116020070	FAN	FAN	1
4	5001030210025	HAVA KAFESİ	AIR CAGE	1
5	5000670100003	FAN SABITLEME PULU	FAN FIXING WASHER	1
6	5001350200009	AHTAPOT KAFA	COMBUSTION HEAD	1
7	5001340100001	TURBULATOR	TURBULATOR	1
8	5001360210116	ALEV BORU UZATMASI	FLAME PIPE EXTENSION	1
9	200064010031	ALEV BORU UZATMA CIVATA	FLAME PIPE EXTENSION SCREW	2
10	5001060200028	KAZAN BAGLANTI FLANSI	BOILER CONNECTION FLANGE	1
11	200056020013	CONTA	GASKET	1
12	5000540200008	KAZAN BAG.FLANSI DESTEK AYAGI	BOILER CONNECTION FLANGE SUPPORT FEET	1
13	200049010092	MENTEŞE GRUBU	HINGE GROUP	1
14	5000530200054	MENTEŞE	HINGE	2
15	2 022 075 0001	ATEŞLEME TRAFOSU	IGNITION TRANSFORMER	1
16	200025010093	SERVOMOTOR	AIR DAMPER (SERVOMOTOR)	1
17	200043010074	KAPLIN	COUPLIN	1
18	5000440200062	KLAPE MİLİ	CLAMP SHAFT	1
19	5000440210009	KLAPE SACI	CLAMP SHEET	1
20	200058010001	PURJÖR	PURGER	2
21	200058010007	PRES.ADAPTÖR BORULU	PRESSURESTAT ADAPTER	1
22	2 058 491 0001	PRESOSTAT PURJÖRÜ	PRESSURESTAT PURGER	1
23	200056020006	KLİNGRİT CONTA	KLINGRITE GASKET	1
24	5000600100009	GOZETLEME CAMI	OBSERVATION GLASS	1
25	200023010013	PRESOSTAT	PRESSURESTAT	1
26	5000600200001	GÖZETLEME CAMI ÇERÇEVESİ	OBSERVATION GLASS FRAME	1
27	5000530210040	PANO SACI	PANEL SHEET	1
28	58101010302020034	PANO	ELECTRICAL PANEL	1
29	200067010007	PUL	WASHER	4
30	200066010008	SOMUN	NUT	4
31	200053020008	SUSTURUCU	SILENCER	1
32	5001360210115	ALEV BORUSU	FLAME PIPE	1
33	5000380210056	GAZ GİRİŞ BORUSU	GAS INLET PIPE	1
34	200056010763	ORİNG 81,92X5,34(4H-139)	ORİNG 81,92X5,34(4H-139)	1
35	5000380210057	GAZ YOLU BORUSU	GAS LINE PIPE	1
36	200119010220	GAZ VENTİLİ	GAS VALVE	1
37	3000370015	ETİKET	LABEL	1
38	5000570200005	ETİKET	LABEL	1
39	200133010020	ELEKT.ATEŞ.	ELECTRODE IGNITION	1
40	200133010033	İYONİZASYON ELEKTRODU	IONIZATION ELECTRODE	1



Termo Isı Sistemleri San. Ve Tic. A.Ş. reserves the right to change the brand and specifications of the mentioned equipments. Therefore, please obtain confirmation from the sales and after-sales service department regarding the product code.

4. GAS, FLUE GAS AND HEATING WATER SCHEMA

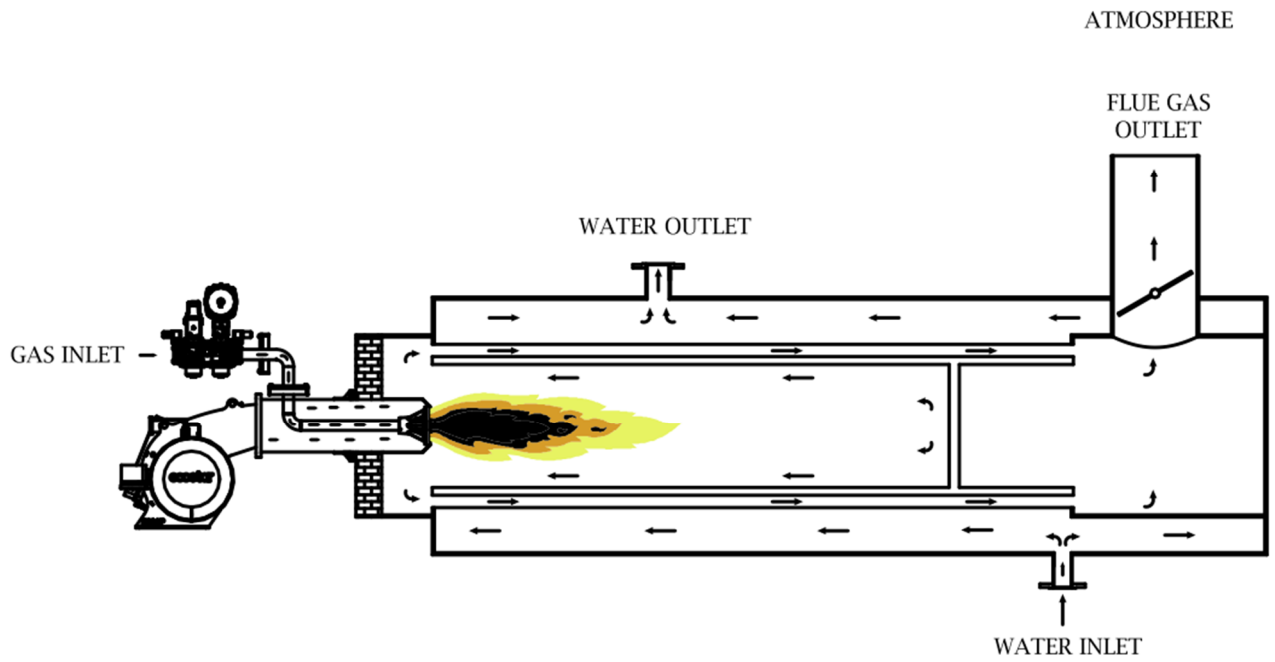

5. TECHNICAL DATA

5.1.Capacity Table

One Stage HP Burners

HIGH FAN PRESSURE ONE STAGE GAS BURNERS CAPACITY TABLE												
BURNER TYPE	CAPACITY		CAPACITY				NATURAL GAS CONSUMPTION		FAN MOTOR POWER	MAIN SUPPLY	GAS INLET DIAMETER	
	Min. kcal/h	Max. kcal/h	Min.	kW	Max.	kW	Min. Nm ³ /h	Max. Nm ³ /h	kW	VAC	Gas Valve	Gas Inlet Diameter
ECO 50 HP G C1 SV	8.600	43.000	10	50	1	5	0,1	1N 230	ZEVR DN15	1/2"		
ECO 100 HP G C1 SV	17.200	86.000	20	100	2	10	0,2	1N 230	ZEVR DN20	3/4"		
ECO 200 HP G C1 SV	68.800	172.000	80	200	8	21	0,3	1N 230	ZEVR DN32	1 1/4"		
ECO 200 HP G C1 1/2" D	68.800	172.000	80	200	8	21	0,3	1N 230	MB-DLE 405	1/2"		
ECO 200 HP G C1 3/4" D									MB-DLE 407	3/4"		
ECO 350 HP G C1 3/4" D	77.400	301.000	90	350	9	36	0,3	1N 230	MB-DLE 407	3/4"		
ECO 350 HP G C1 1" D									MB-DLE 410	1"		
ECO 350 HP G C1 1 1/4" D									MB-DLE 412	1 1/4"		

H_u Natural Gas =8250 kcal/Nm³

H_u LPG=22500 kcal/Nm³

Two Stage HP Burners

HIGH FAN PRESSURE TWO STAGE GAS BURNERS CAPACITY TABLE

BURNER TYPE	CAPACITY		CAPACITY		NATURAL GAS CONSUMPTION		FAN MOTOR POWER	MAIN SUPPLY	GAS INLET DIAMETER	
	Min. kcal/h	Max. kcal/h	Min. kW	Max. kW	Min. Nm ³ /h	Max. Nm ³ /h	kW	VAC	Gas Valve	Gas Inlet Diameter
ECO 200 HP GC 2 1/2" D	68.800	172.000	80	200	8	21	0,2	1N 230	MB-ZRDLE 405	1/2"
ECO 200 HP GC 2 3/4" D									MB-ZRDLE 407	3/4"
ECO 350 HP GC 2 3/4" D	77.400	301.000	90	350	9	36	0,3	1N 230	MB-ZRDLE 407	3/4"
ECO 350 HP GC 2 1" D									MB-ZRDLE 410	1"
ECO 450 HP G C2 3/4" D	129.000	387.000	150	450	16	47	0	1N 230	MB-DLE 407	3/4"
ECO 450 HP G C2 1" D									MB-DLE 410	1"
ECO 450 HP G C2 1 1/4" D									MB-DLE 412	1 1/4"
ECO 700 HP GC 2 1 1/4" D	215.000	602.000	250	700	26	73	0,75	3N 400	MB-ZRDLE 412	1 1/4"
ECO 700 HP GC 2 1 1/2" D									MB-ZRDLE 415	1 1/2"
ECO 1100 HP GC 2 1 1/4" D	215.000	946.000	250	1100	26	115	1,5	3N 400	MB-ZRDLE 412	1 1/4"
ECO 1100 HP GC 2 1 1/2" D									MB-ZRDLE 415	1 1/2"
ECO 1100 HP GC 2 2" D									MB-ZRDLE 420	2"
ECO 1100 HP GC 2 1 1/2" -S									VDG 20.4011	1 1/2"
ECO 1100 HP GC 2 2" -S									VDG 20.5011	2"
ECO 1500 HP GC 2 1 1/2" -S	258.000	1.290.000	300	1.500	31	156	1,5	3N 400	VDG 20.4011	1 1/2"
ECO 1500 HP GC 2 2" -S									VDG 20.5011	2"
ECO 2000 HP GC 2 1 1/2" -S	473.000	1.720.000	550	2.000	57	208	3	3N 400	VDG 20.4011	1 1/2"
ECO 2000 HP GC 2 2" -S									VDG 20.5011	2"
ECO 2000 HP GC 2 DN65									VDG 40.065	DN65
ECO 3000 HP GC 2 1 1/2" -S									VDG 20.4011	1 1/2"
ECO 3000 HP GC 2 2" -S	516.000	2.580.000	600	3.000	63	313	4	3N 400	VDG 20.5011	2"
ECO 3000 HP GC 2 DN65									VDG 40.065	DN65
ECO 3000 HP GC 2 DN80									VDG 40.080	DN80
ECO 4500 HP GC 2 1 1/2" -S									VDG 20.4011	1 1/2"
ECO 4500 HP GC 2 2" -S	645.000	3.870.000	750	4.500	78	469	7,5	3N 400	VDG 20.5011	2"
ECO 4500 HP GC 2 DN65									VDG 40.065	DN65
ECO 4500 HP GC 2 DN80									VDG 40.080	DN80
ECO 4500 HP GC 2 DN100									VDG 40.0100	DN100
ECO 4500 HP GC 2 DN125									VDG 40.125	DN125

H_u Natural Gas =8250 kcal/Nm³

H_u LPG=22500 kcal/Nm³

Modulating HP Burners

HIGH FAN PRESSURE MODULATING GAS BURNERS CAPACITY TABLE											
BURNER TYPE	CAPACITY		CAPACITY		NATURAL GAS CONSUMPTION		FAN MOTOR POWER	MAIN SUPPLY	GAS INLET DIAMETER		
	Min. kcal/h	Max. kcal/h	Min. kW	Max. kW	Min. Nm ³ /h	Max. Nm ³ /h	kW	VAC	Gas Valve	Gas Inlet Diameter	
ECO 200 HP G C3M 1/2" D	68.800	172.000	80	200	8	21	0,2	1N 230	MB-DLE 405	1/2"	
ECO 200 HP G C3M 3/4" D									MB-DLE 407	3/4"	
ECO 350 HP G C3M 3/4" D	77.400	301.000	90	350	9	36	0,3	1N 230	MB-DLE 407	3/4"	
ECO 350 HP G C3M 1" D									MB-DLE 410	1"	
ECO 350 HP G C3M 1 1/4" D									MB-DLE 412	1 1/4"	
ECO 450 HP G C3M 3/4" D	129.000	387.000	150	450	16	47	0	1N 230	MB-DLE 407	3/4"	
ECO 450 HP G C3M 1" D									MB-DLE 410	1"	
ECO 450 HP G C3M 1 1/4" D									MB-DLE 412	1 1/4"	
ECO 700 HP G C3M 1 1/4" D	215.000	602.000	250	700	26	73	0,75	3N 400	MB-DLE 412	1 1/4"	
ECO 700 HP G C3M 1 1/2" D									MB-DLE 415	1 1/2"	
ECO 1100 HP G C3M 1 1/2" -S	215.000	946.000	250	1.100	26	115	1,5	3N 400	VG D 20.4011	1 1/2"	
ECO 1100 HP G C3M 2" -S									VG D 20.5011	2"	
ECO 1500 HP G C3P 1 1/2" -S	301.000	1.290.000	350	1.500	36	156	1,5	3N 400	VG D 20.4011	1 1/2"	
ECO 1500 HP G C3P 2" -S									VG D 20.5011	2"	
ECO 2000 HP G C3P 1 1/2" -S	473.000	1.720.000	550	2.000	57	208	3	3N 400	VG D 20.4011	1 1/2"	
ECO 2000 HP G C3P 2" -S									VG D 20.5011	2"	
ECO 2000 HP G C3P DN65									VG D 40.065	DN65	
ECO 3000 HP G C3P 1 1/2" -S	516.000	2.580.000	600	3.000	63	313	4	3N 400	VG D 20.4011	1 1/2"	
ECO 3000 HP G C3P 2" -S									VG D 20.5011	2"	
ECO 3000 HP G C3P DN65									VG D 40.065	DN65	
ECO 3000 HP G C3P DN80									VG D 40.080	DN80	
ECO 4500 HP G C3P 1 1/2" -S	645.000	3.870.000	750	4.500	78	469	7,5	3N 400	VG D 20.4011	1 1/2"	
ECO 4500 HP G C3P 2" -S									VG D 20.5011	2"	
ECO 4500 HP G C3P DN65									VG D 40.065	DN65	
ECO 4500 HP G C3P DN80									VG D 40.080	DN80	
ECO 4500 HP G C3P DN100									VG D 40.100	DN100	
ECO 4500 HP G C3P DN125									VG D 40.125	DN125	

H_u Natural Gas =8250 kcal/Nm³

H_u LPG=22500 kcal/Nm³

5.2.Back Pressure and Gas Line Selection Table

One Stage HP Burners

ECO 50 HP G C1

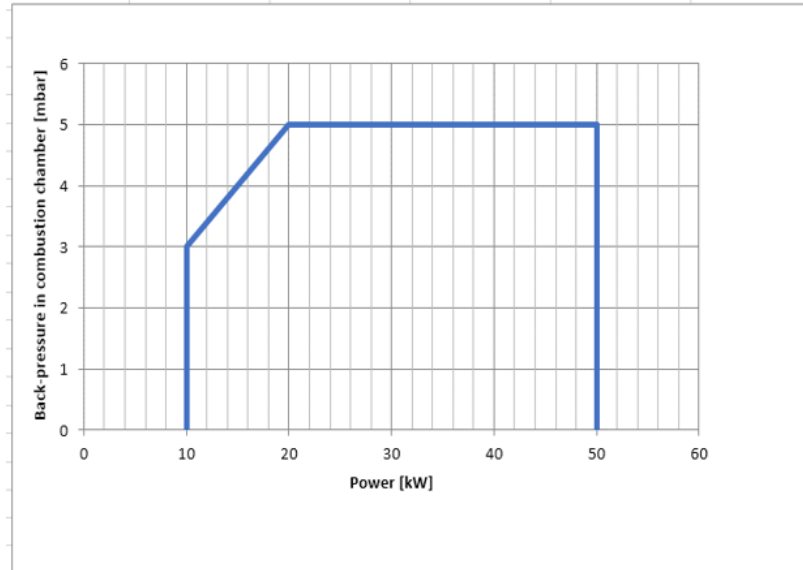

ECO 100 HP G C1

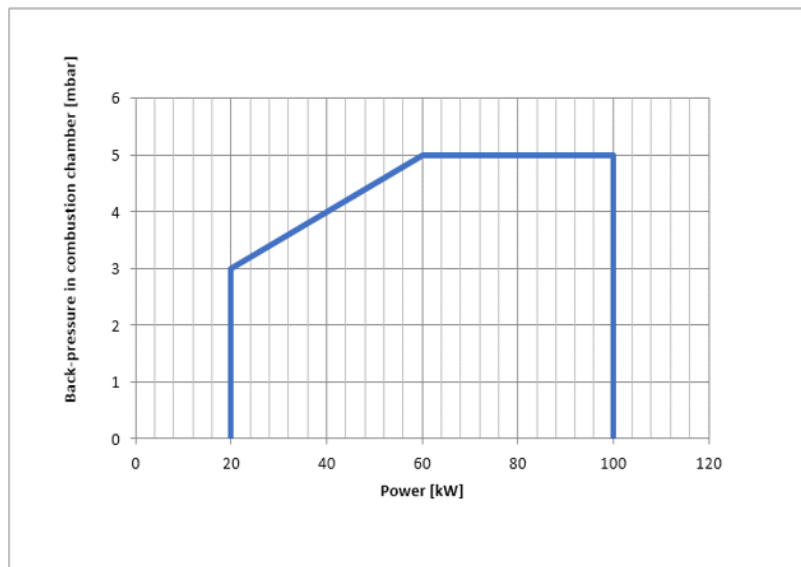

ECO 200 HP G C1

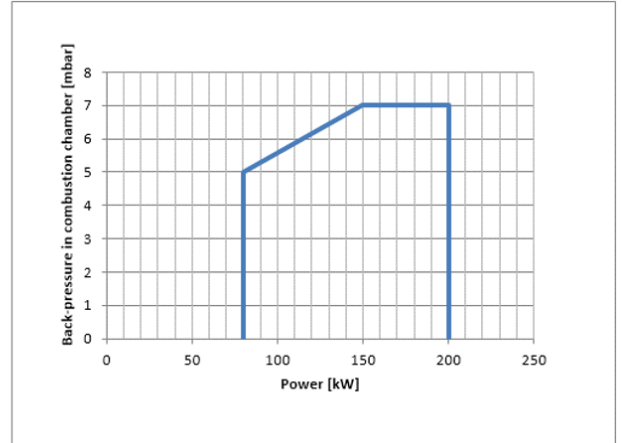
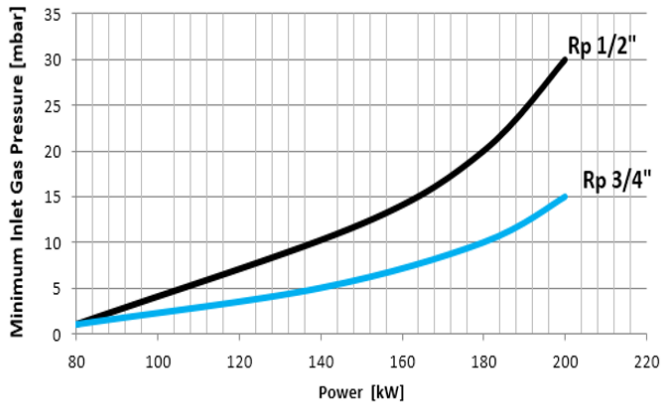

ECO 350 HP G C1

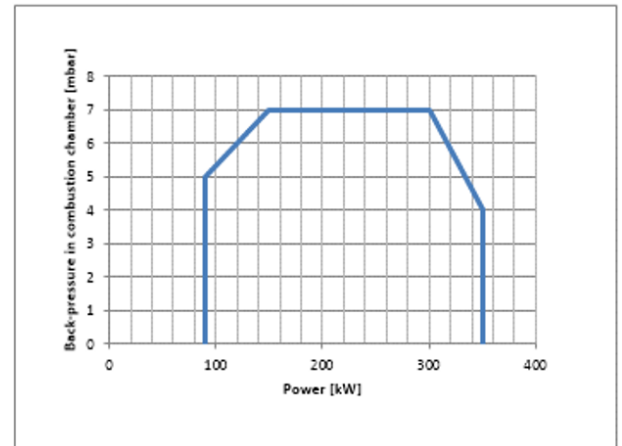
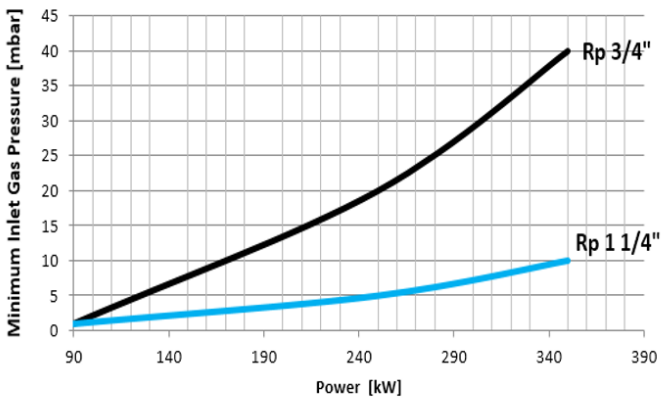

Two Stage HP Burners

ECO 200 HP G C2

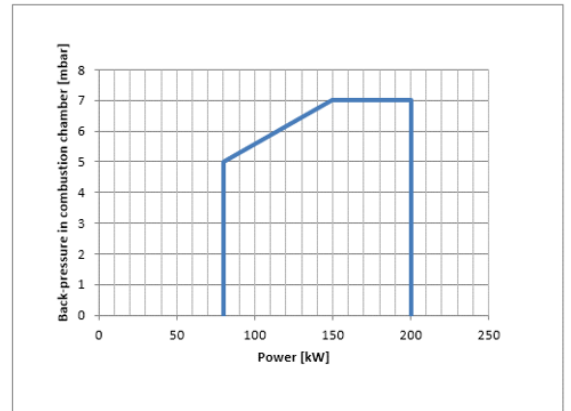
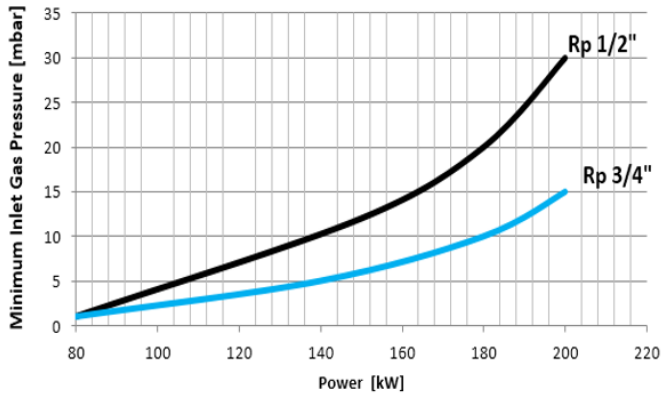

ECO 350 HP G C2

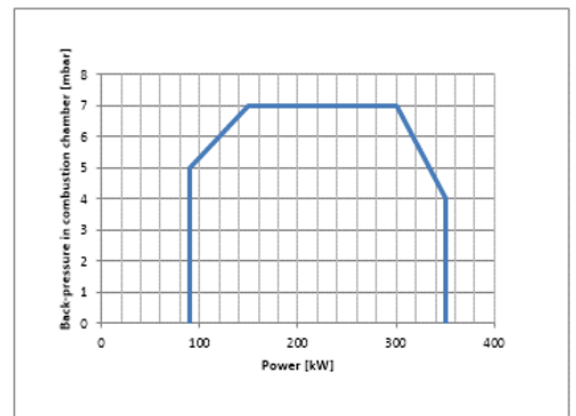
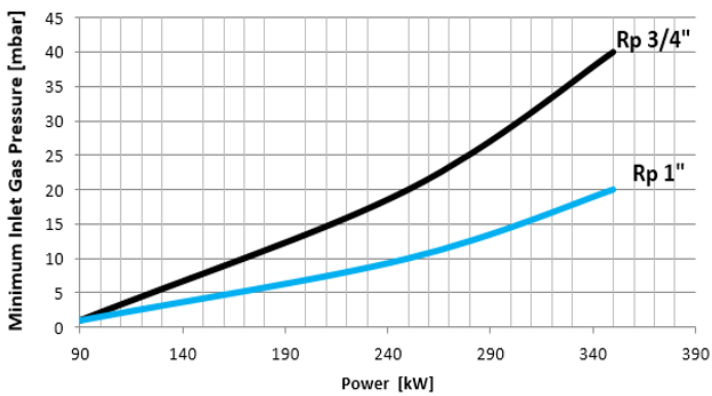

ECO 450 HP G C2

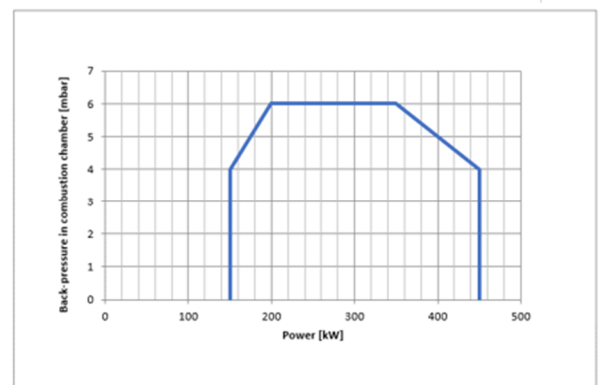
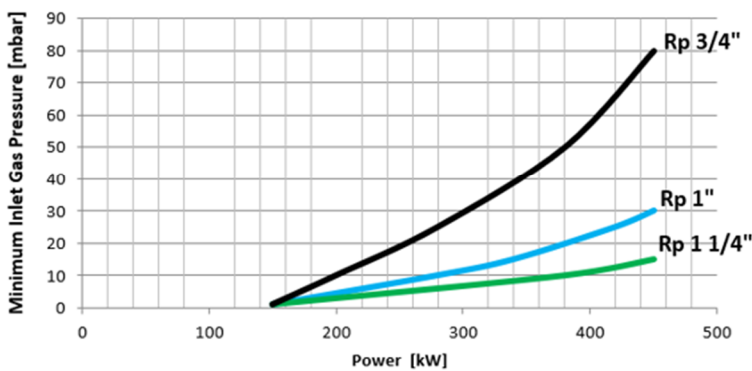

ECO 700 HP G C2

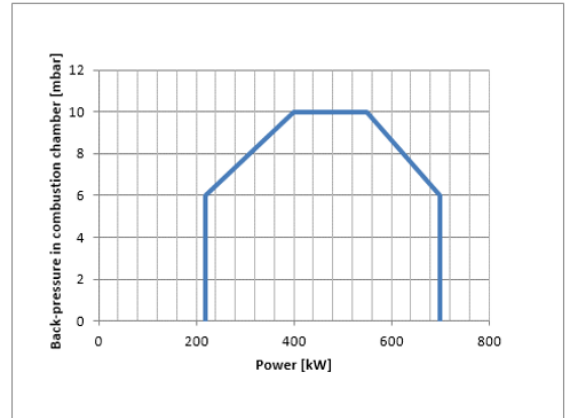
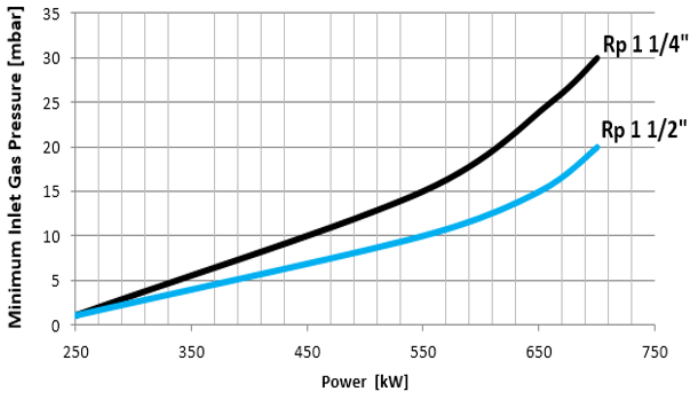

ECO 1100 HP G C2

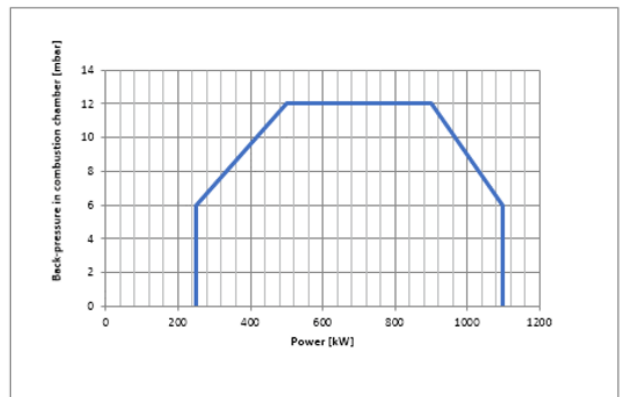
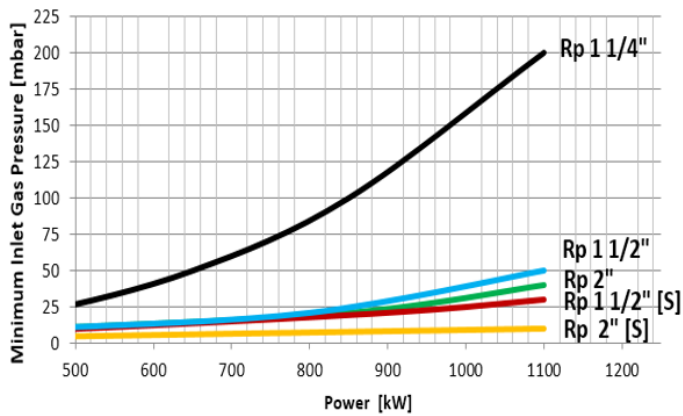

ECO 1500 HP G C2

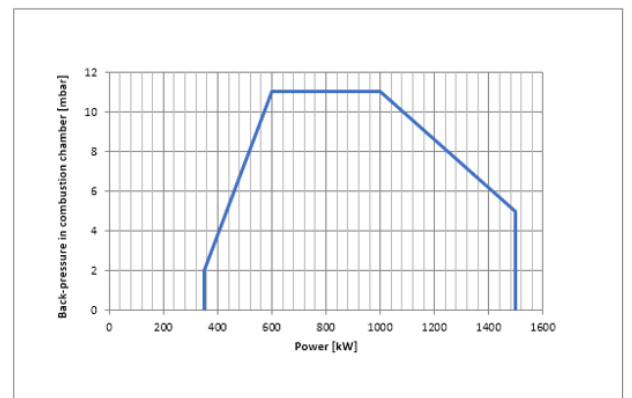
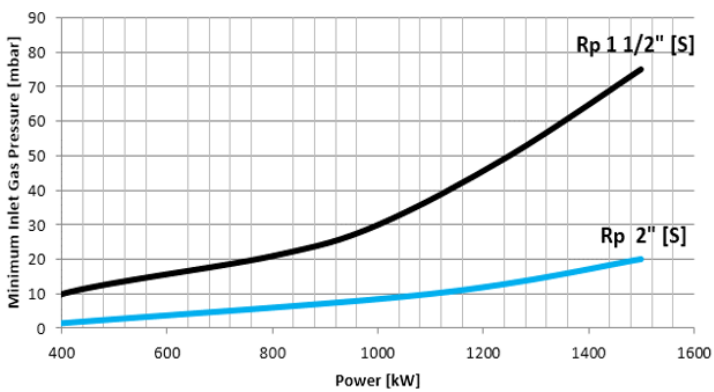

ECO 2000 HP G C2

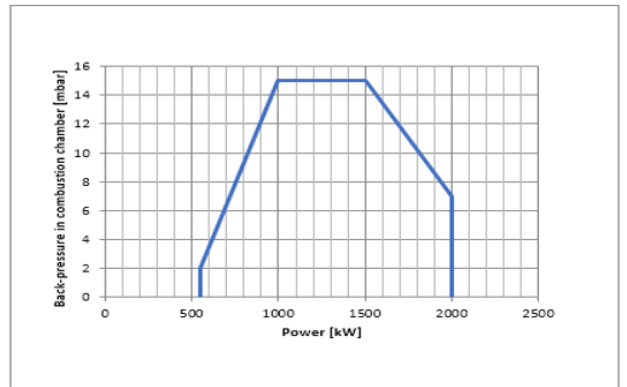
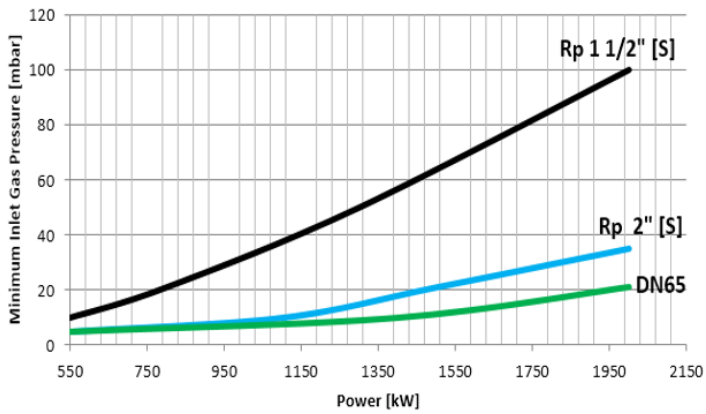

ECO 3000 HP G C2

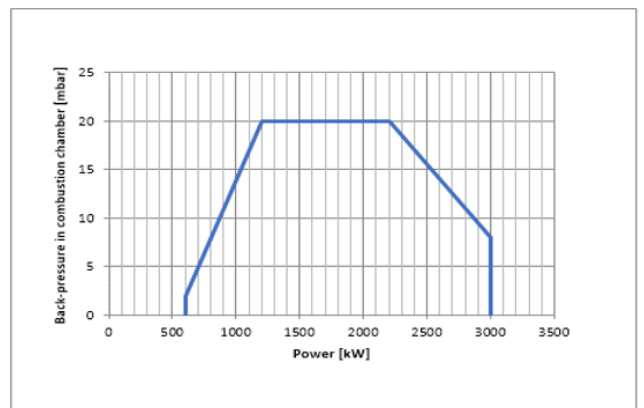
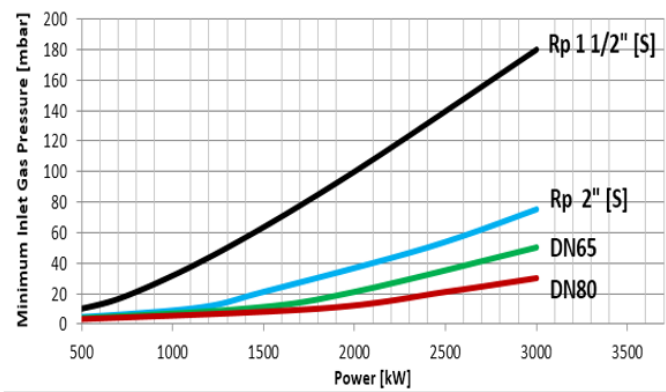

ECO 4500 HP G C2

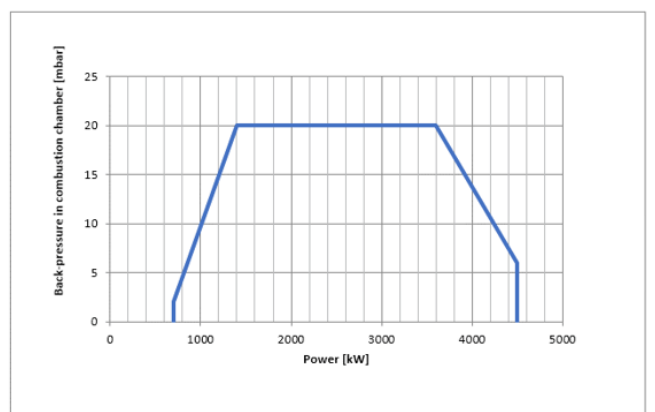
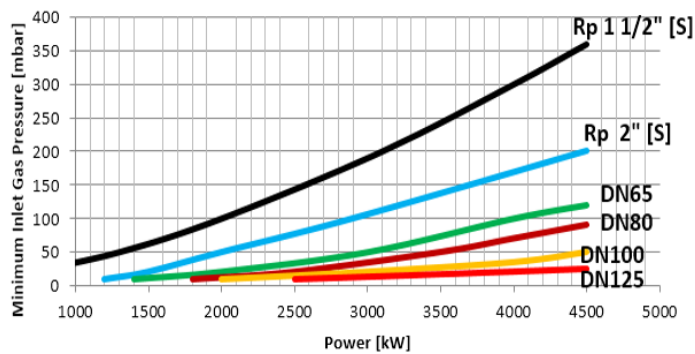

Modulating HP Burners

ECO 200 HP G C3

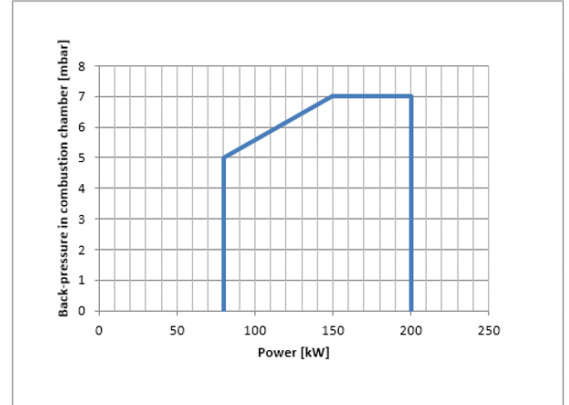
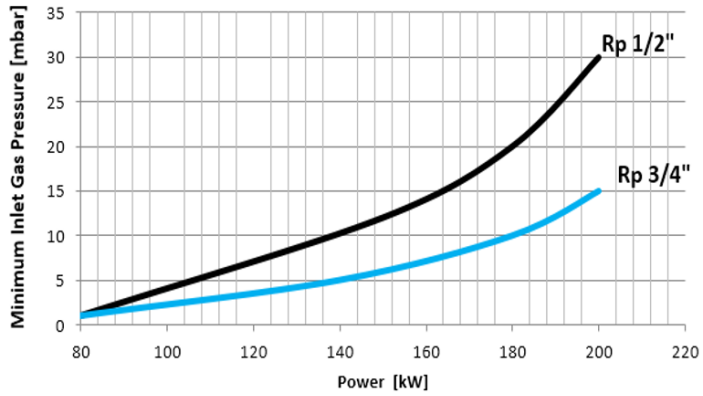

ECO 350 HP G C3

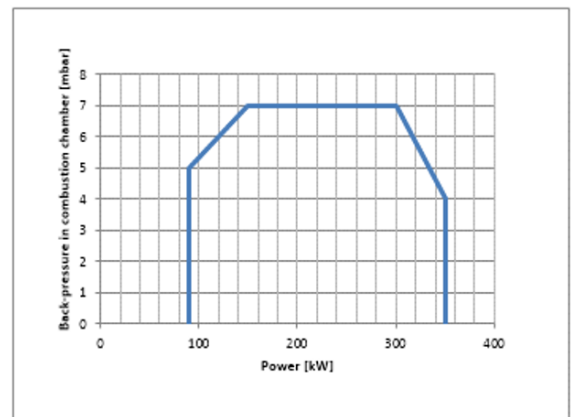
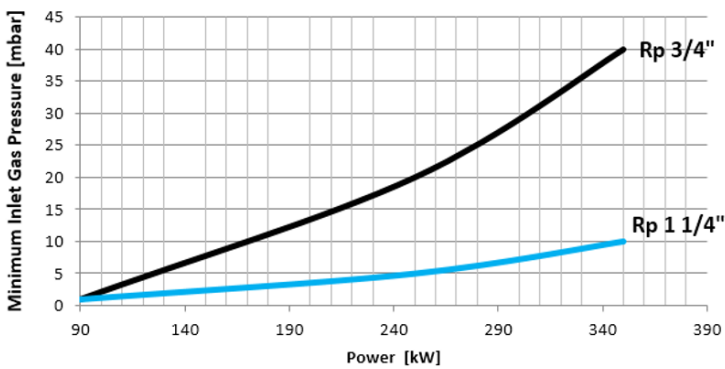

ECO 450 HP G C3

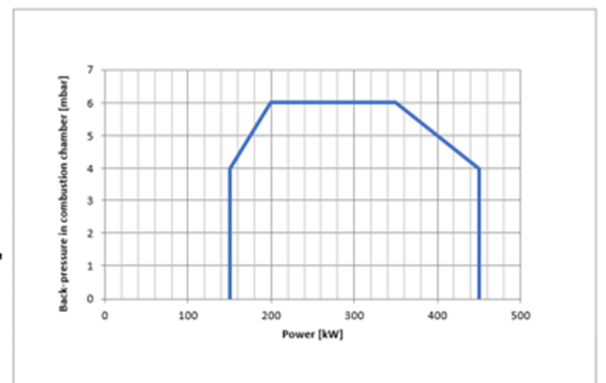
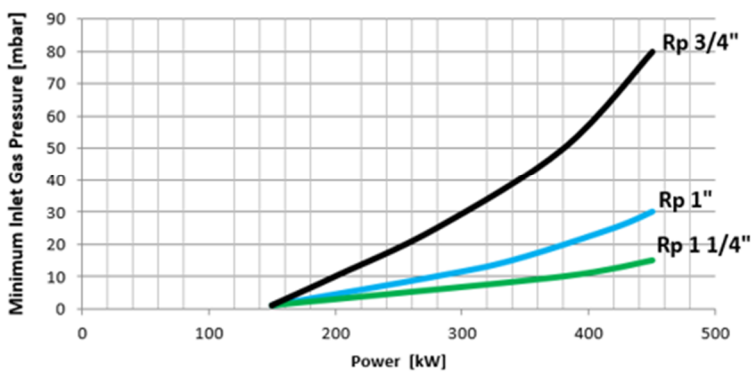

ECO 700 HP G C3

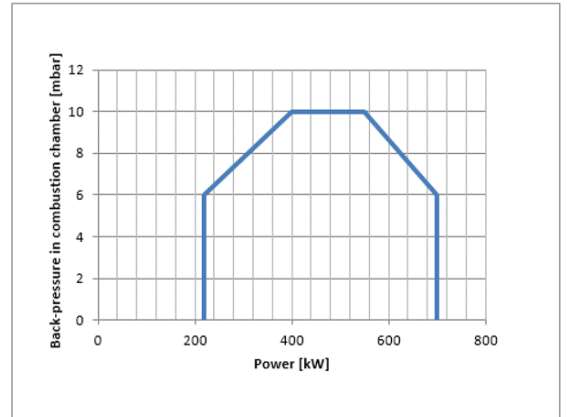
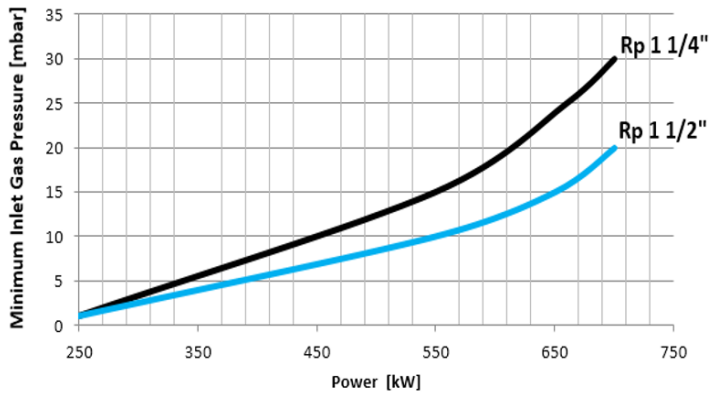

ECO 1100 HP G C3

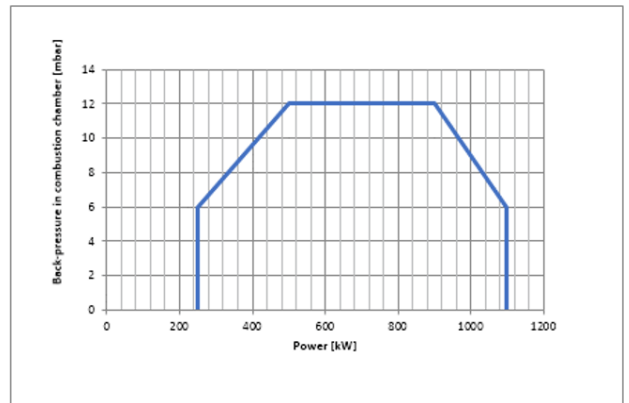
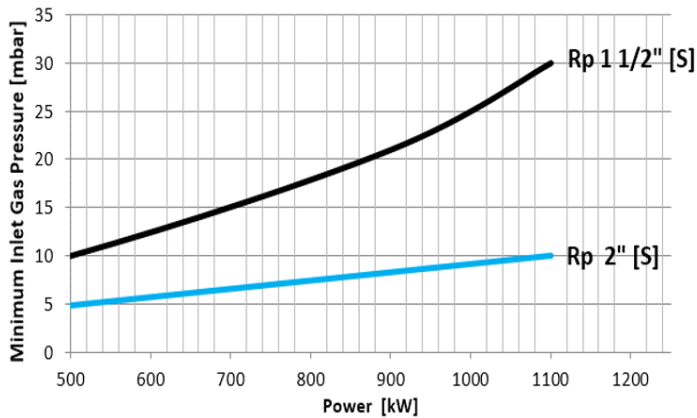

ECO 1500 HP G C3

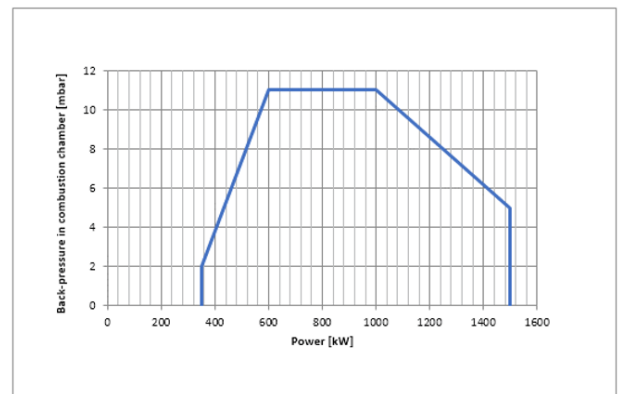
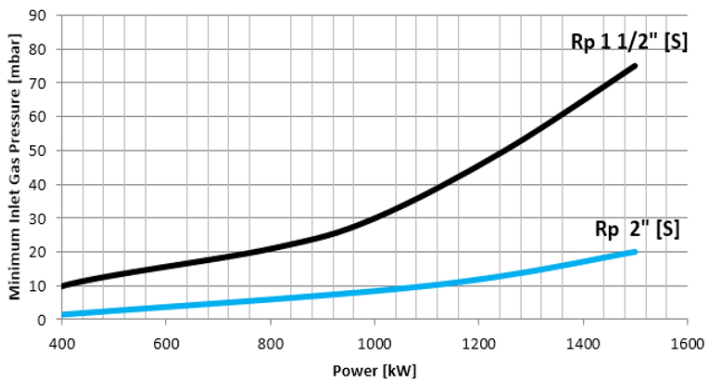

ECO 2000 HP G C3

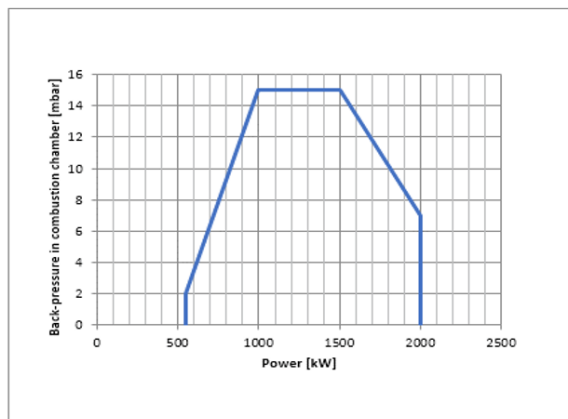
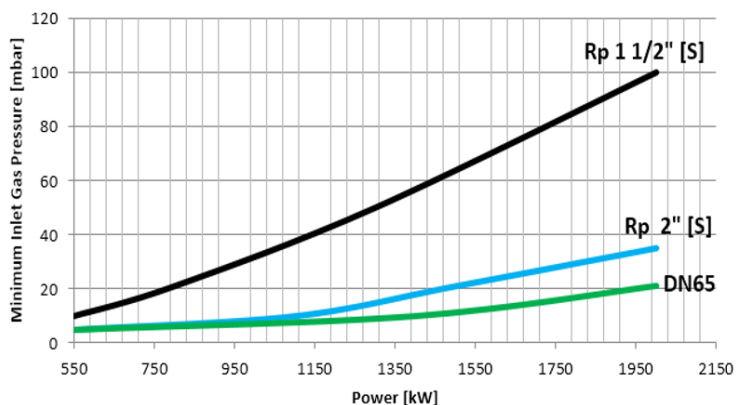

ECO 3000 HP G C3

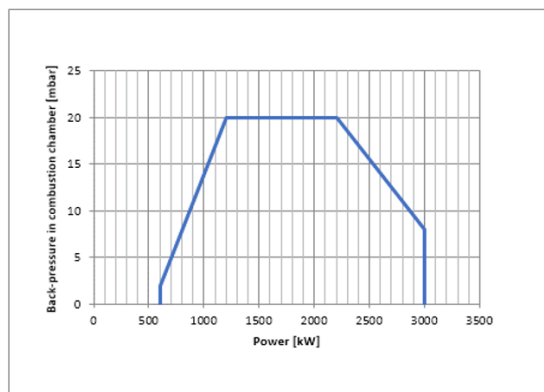
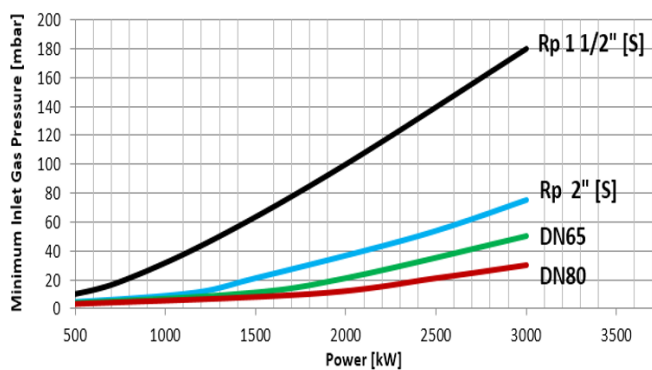

ECO 4500 HP G C3

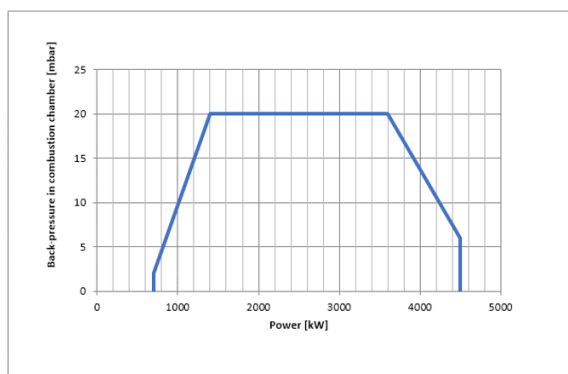
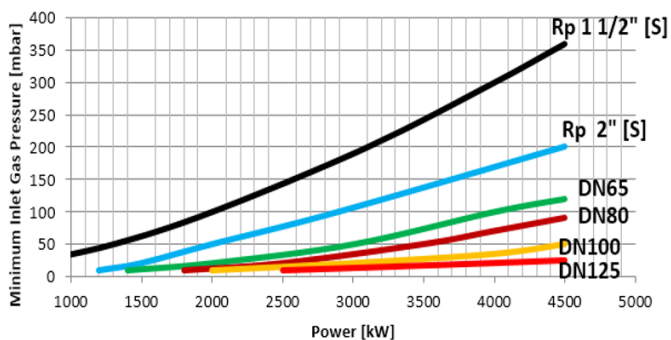

5.3. Gas Valve Outlet Pressure

➤ **MB-DLE/ZRDLE 407**

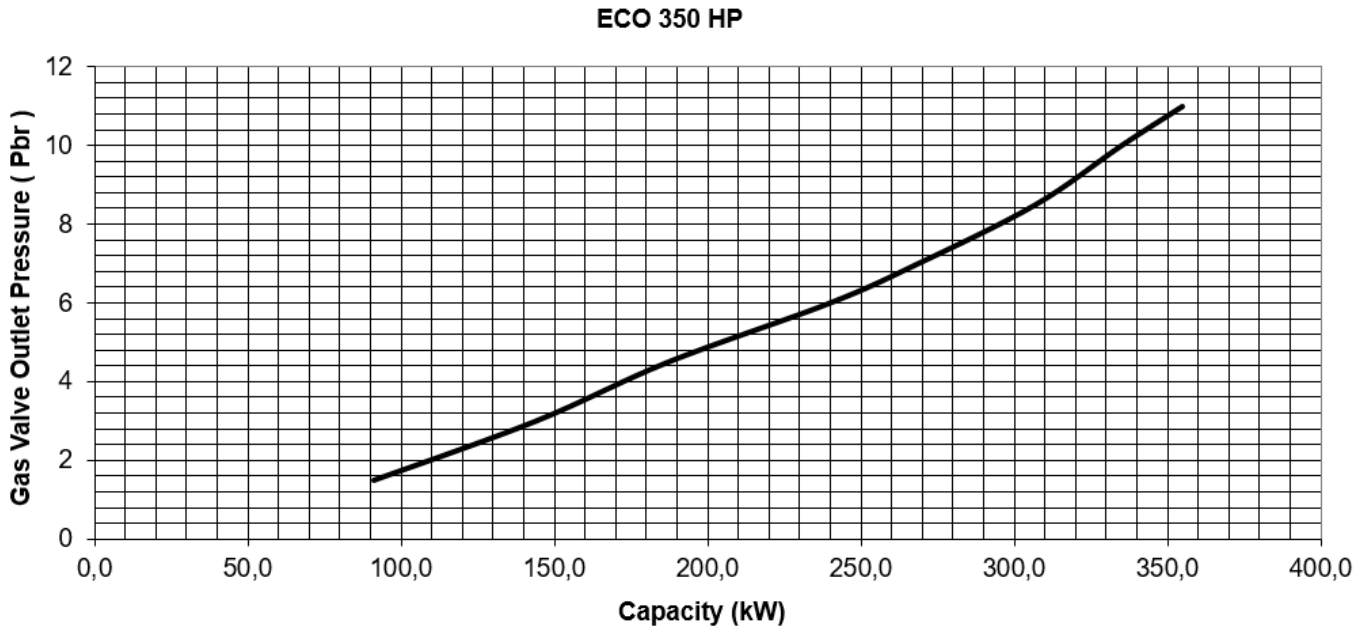

➤ **MB-DLE/ZRDLE 407**

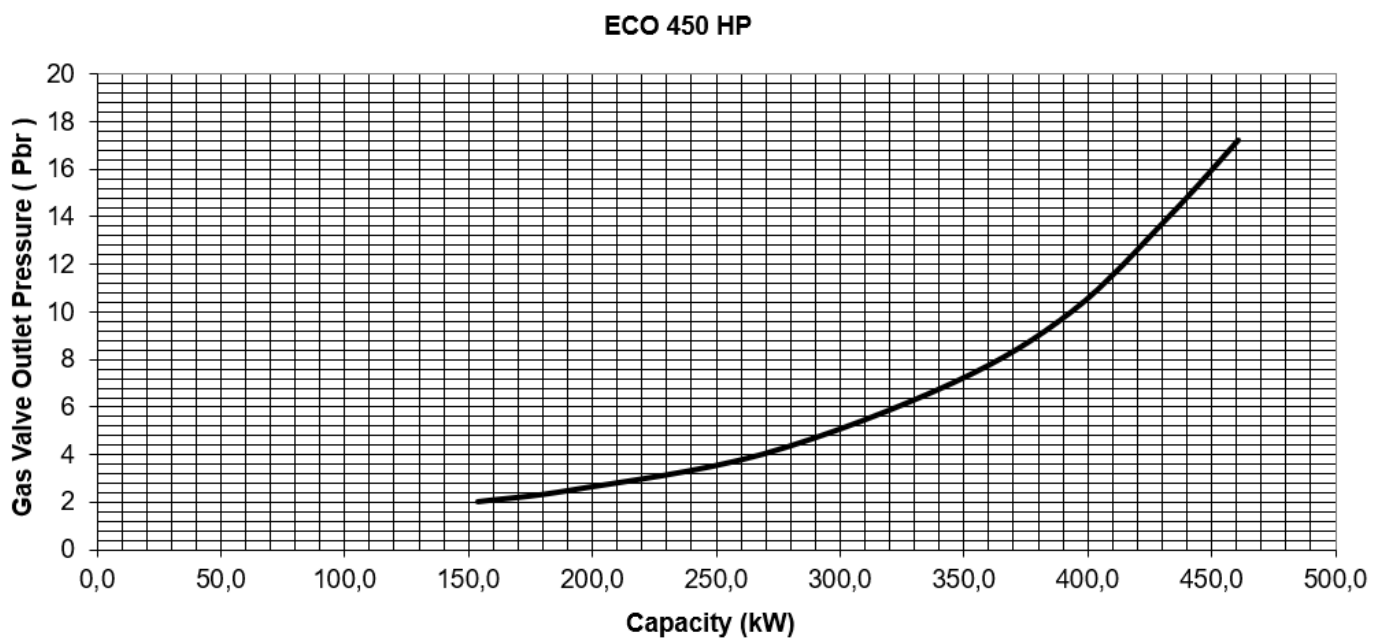

➤ **MB-DLE/ZRDLE 412**

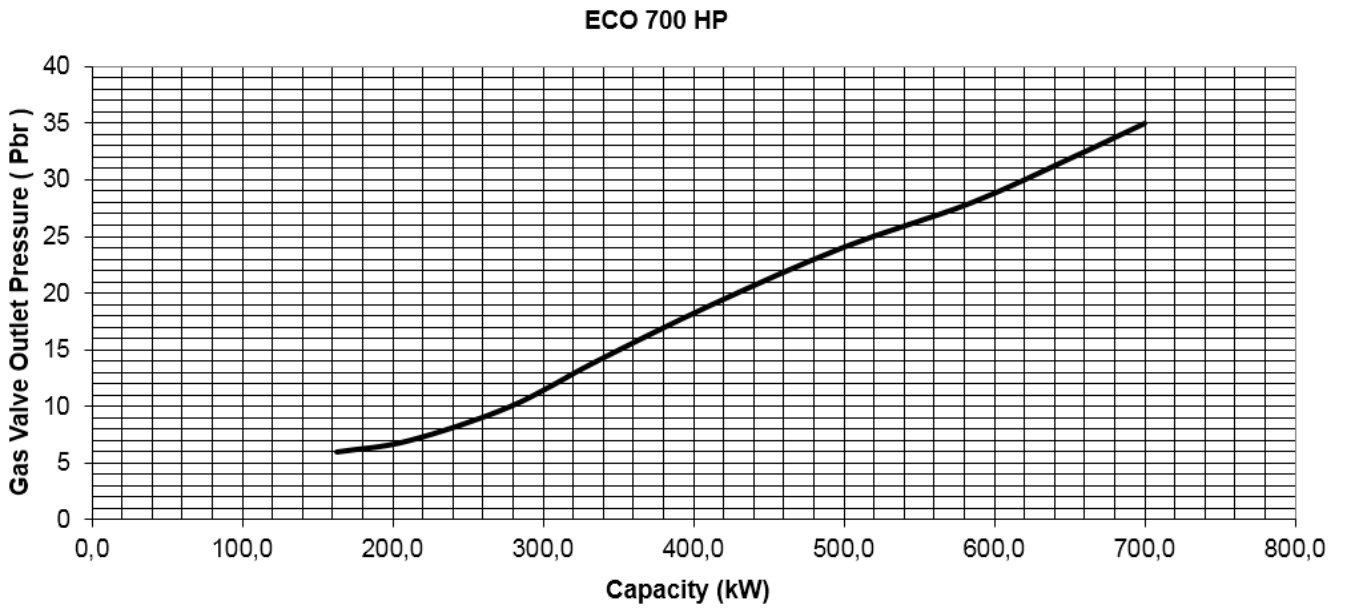

➤ **MB-DLE/ZRDLE 420**

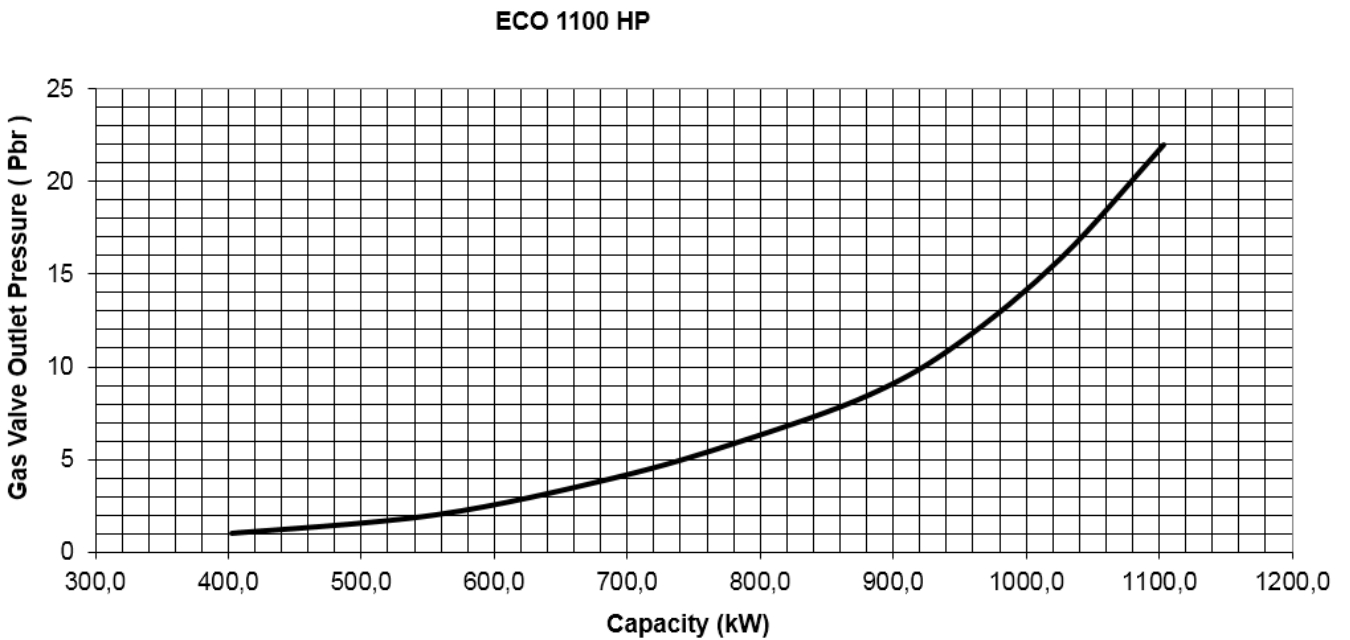

➤ VGD 20.4011

ECO 1500 HP

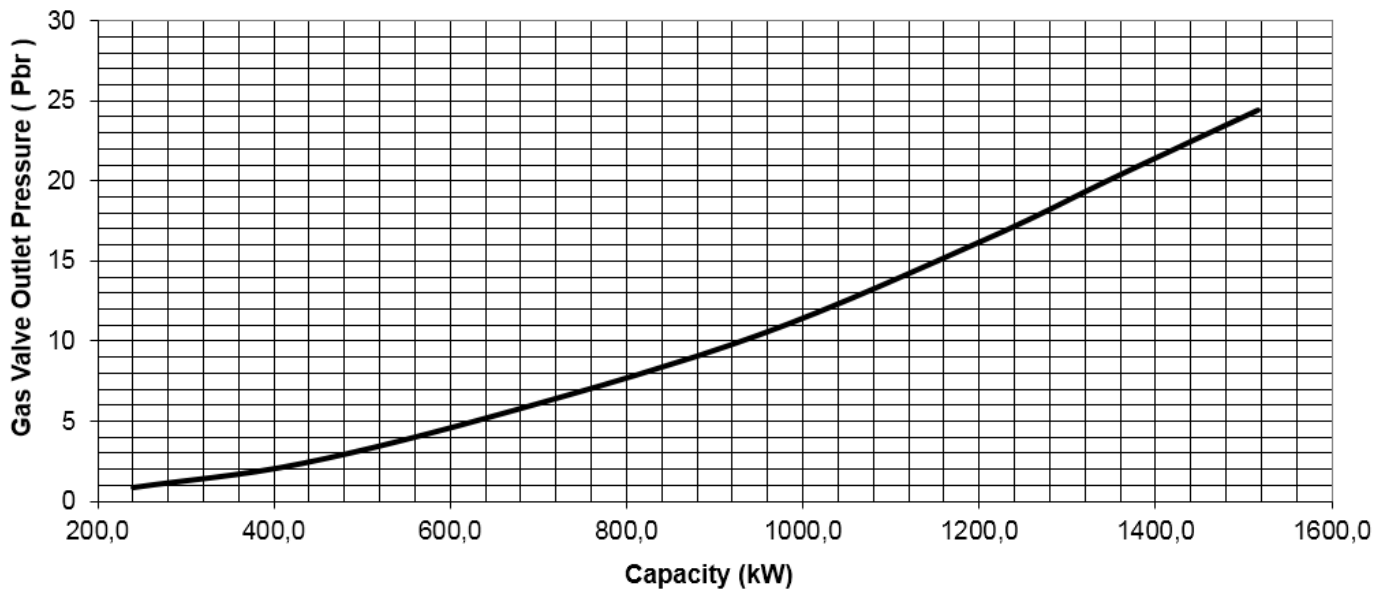

➤ VGD 20.4011

ECO 2000 HP

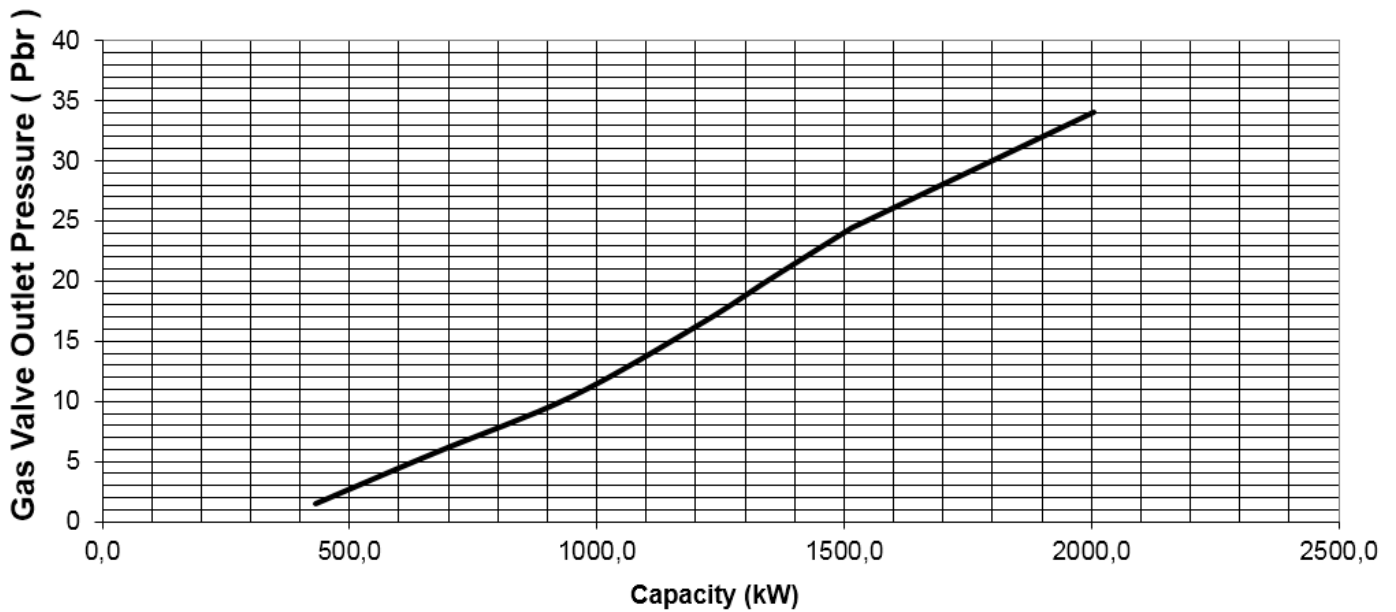

➤ VGD 40.065

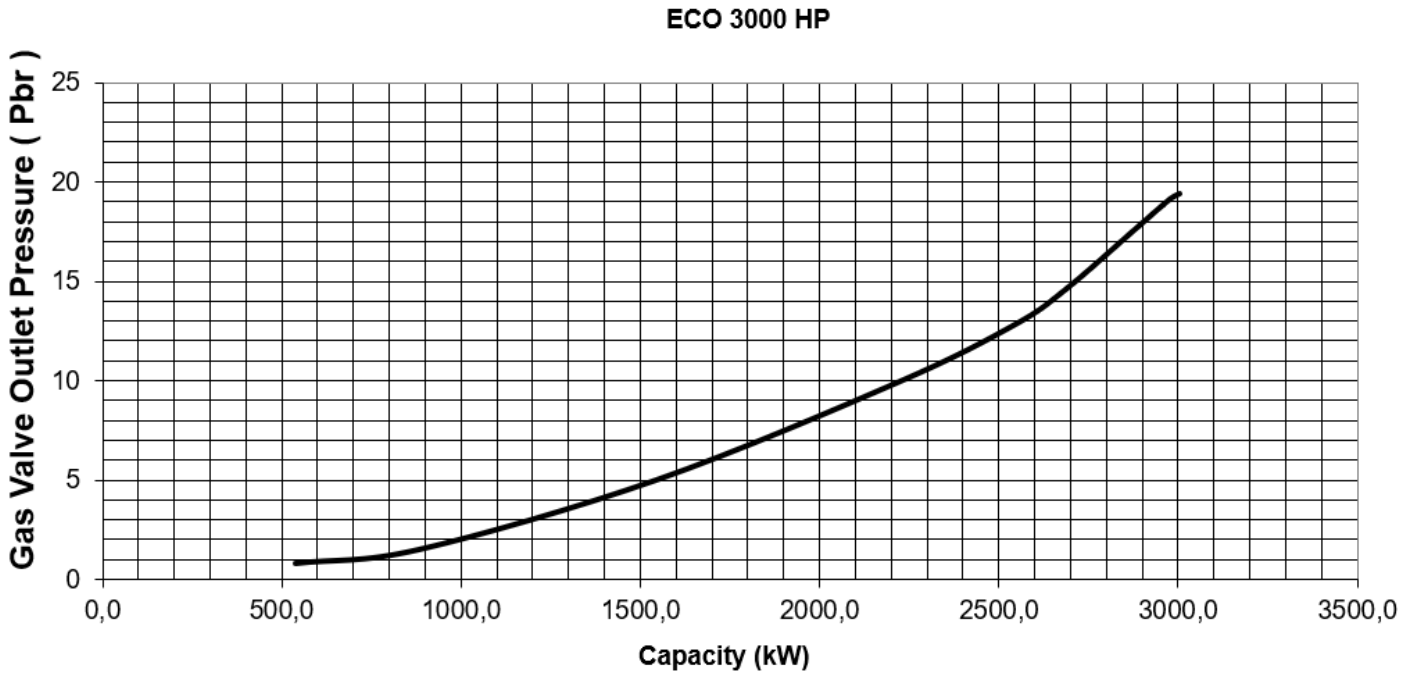

➤ VGD 20.4011

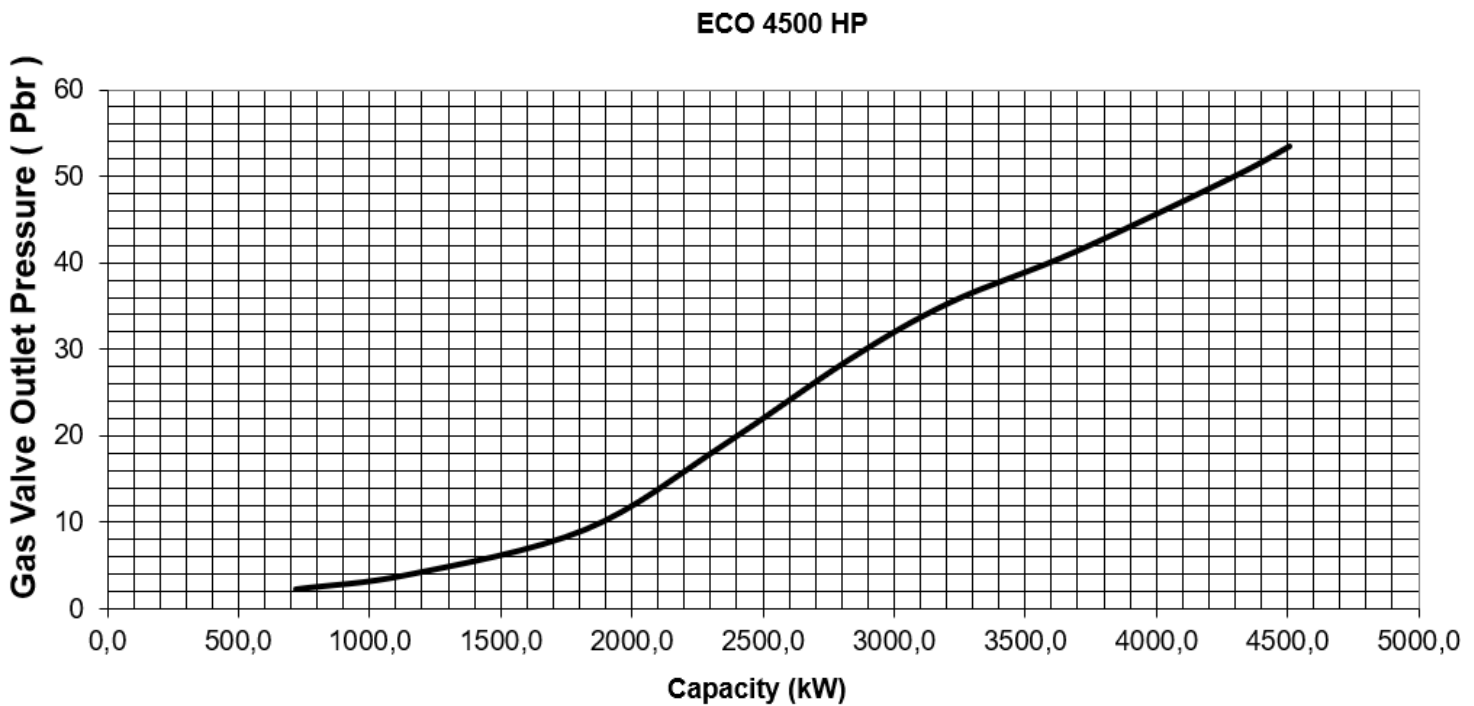

5.4. Burner Dimensions

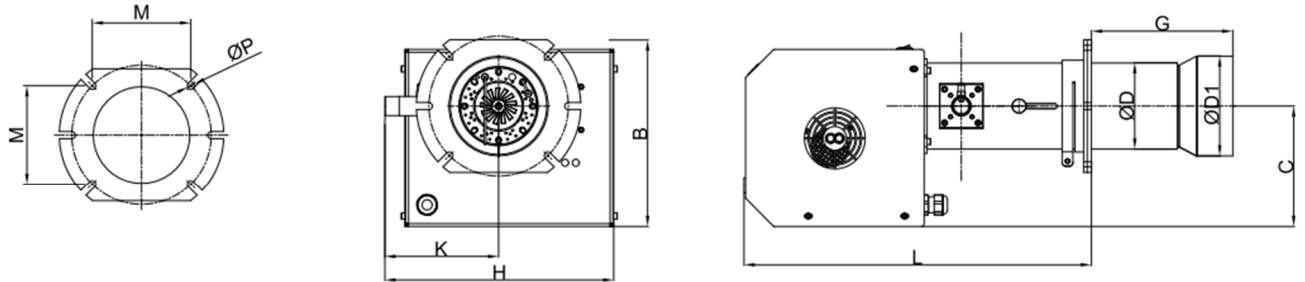

	L	Gmin	Gmax	H	K	B	C	ØP	M	ØD	ØD1
ECO 50 HP	486	198	248	320	160	262	170	10	142	120	139
ECO 100 HP	486	198	248	320	160	262	170	10	142	120	139
ECO 200 HP G C1	486	198	248	320	160	262	170	10	142	120	139
ECO 200 HP G C2	486	198	248	320	160	302	170	10	142	120	139
ECO 350 HP G C1	486	198	248	320	160	262	170	10	142	120	139
ECO 350 HP G C2	486	198	248	320	160	302	170	10	142	120	139

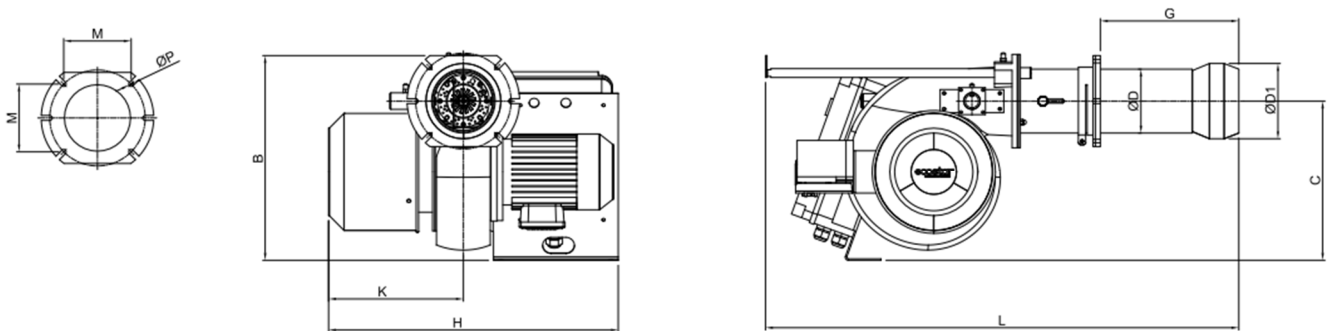

	L	Gmin	Gmax	H	K	B	C	ØP	M	ØD	ØD1
ECO 450 HP G C2	968	283	323	556	276	400	308	10	142	130	153
ECO 450 HP G C3	968	283	323	646	330	419	326	10	142	130	153
ECO 700 HP G C2	968	283	323	584	276	400	306	10	142	130	153
ECO 700 HP G C3	968	283	323	646	330	419	326	10	142	130	153
ECO 1100 HP G C2	1030	260	300	617	315	461	351	12	180	148	172
ECO 1100 HP G C3	1030	260	300	639	318	461	351	12	180	148	172

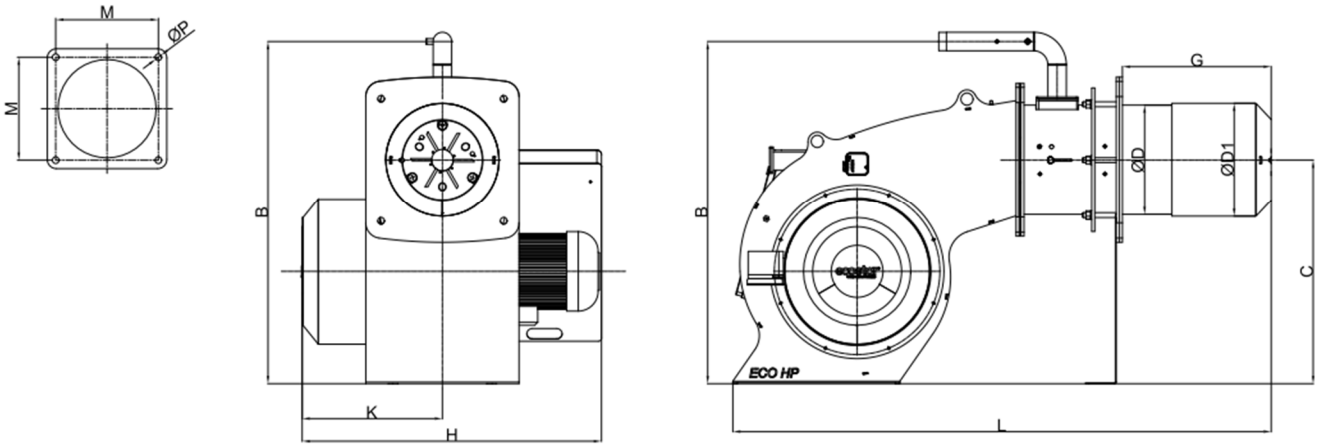

	L	Gmin	Gmax	H	K	B	C	ØP	M	ØD	ØD1
ECO 1500 HP G	1228	349	389	764	347	690	423	18	275	218	228
ECO 2000 HP G	1351	397	437	799	372	778	477	18	275	248	258
ECO 3000 HP G	1639	486	556	926	422	976	648	22	335	302	312
ECO 4500 HP G	1757	485	555	977	458	1135	730	22	400	358	370

5.5.Flame Length and Diameter

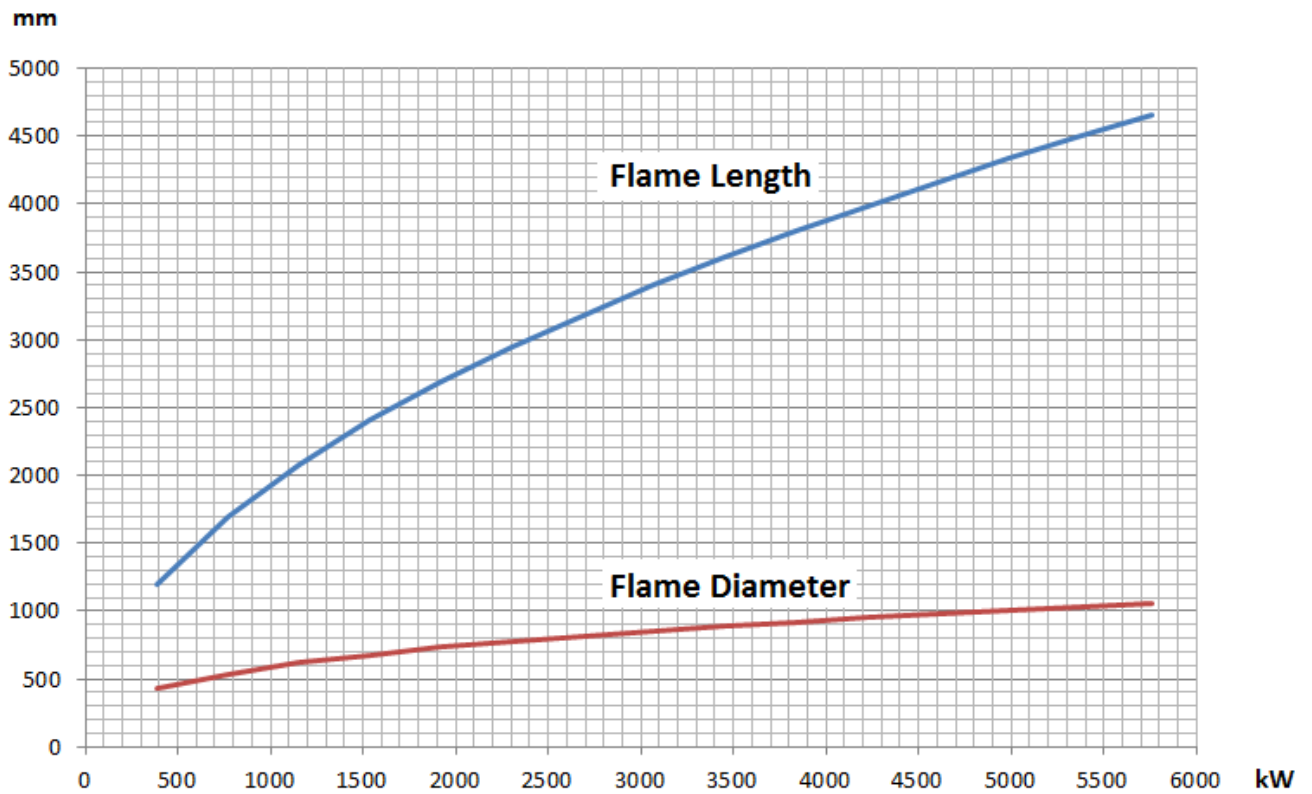

5.6.Noise Level

Product operates within the range of 75 decibels max. and 85 decibels.

6. BURNER HANDLING INFORMATION

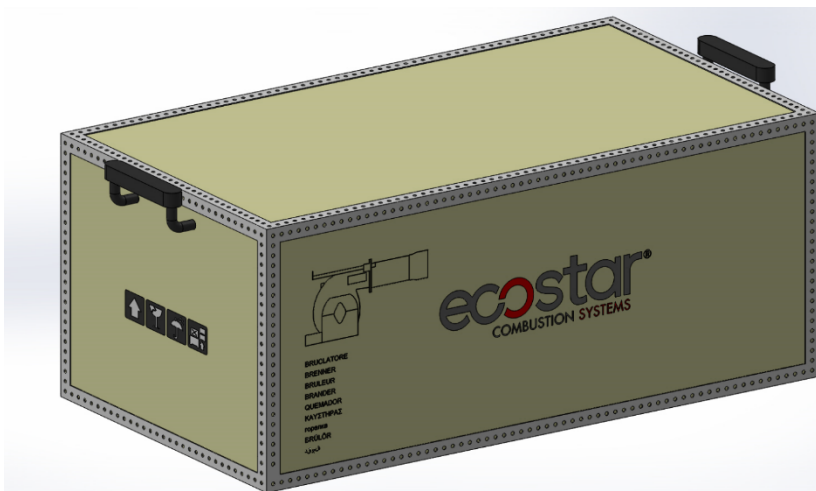

- Lift the product by holding the handles as seen in the picture.
- Prevent strong impacts on top of the product and vibration while handling the product.
- Do not leave the product in wet environment.

7. INSTALLATION

7.1. Burner Installation Picture

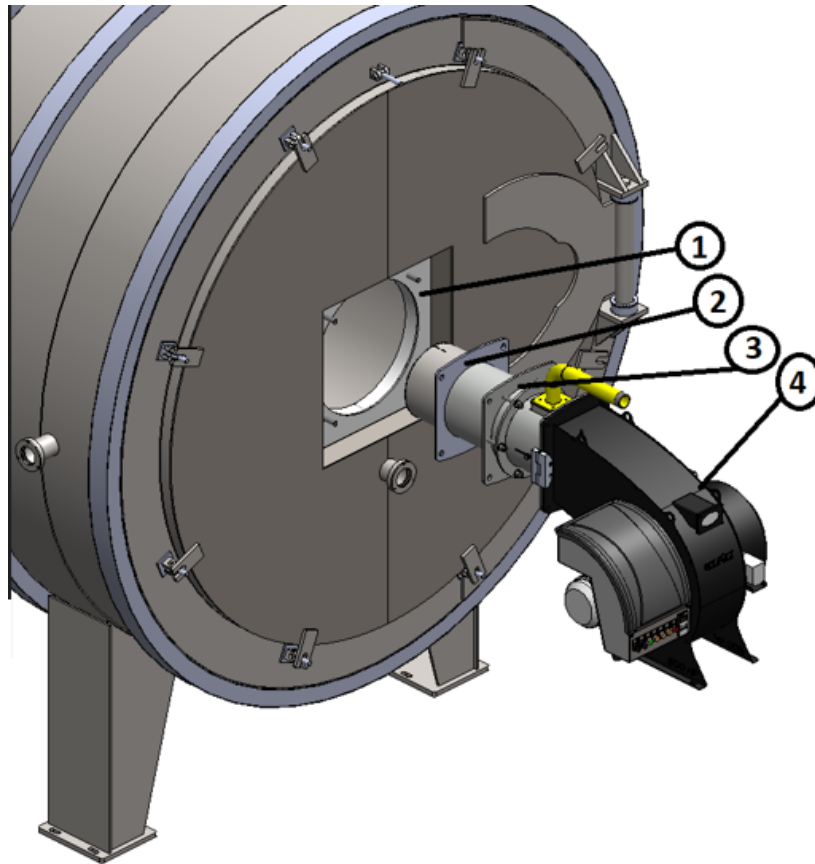

- 1- Boiler Flange
- 2- Gasket
- 3- Boiler Connection Flange
- 4- Burner



You must definitely ensure sealing between boiler and burner!



Device must be shipped in original packaging!



Do not lift the device holding from servomotor, gas valve, impulse pipes or pressure switch during installation!



Clean the inside of fuel line thoroughly before installing the burner to the fuel line. Any damage that may occur due to solid objects and metal particles from the fuel line shall not be covered by our company.

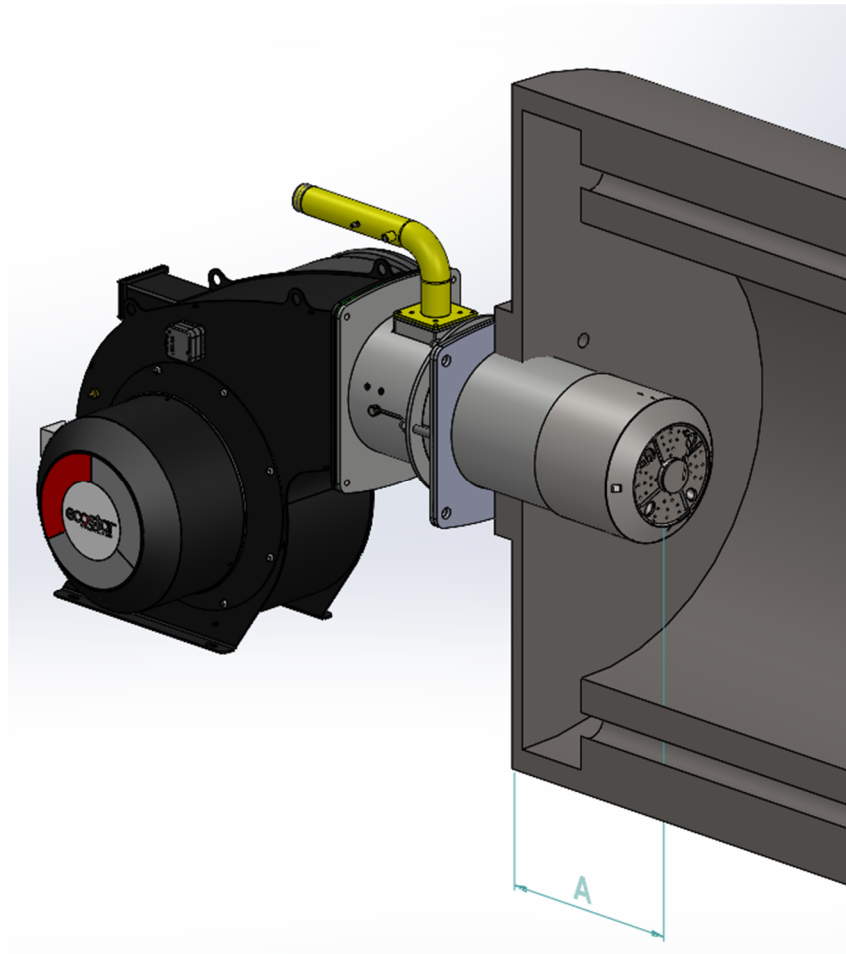

While installing the burner in reverse flame front mirror boilers, flame tube tip must be adjusted such that it gets inside by 50 mm-100 mm from flue pipes ($50\text{mm} \leq A \leq 100\text{mm}$). Otherwise flue gas temperature will rise and fuel consumption will increase.

8. COMMISSIONING

8.1. Before Commissioning

8.1.1. Ignition and Ionization System

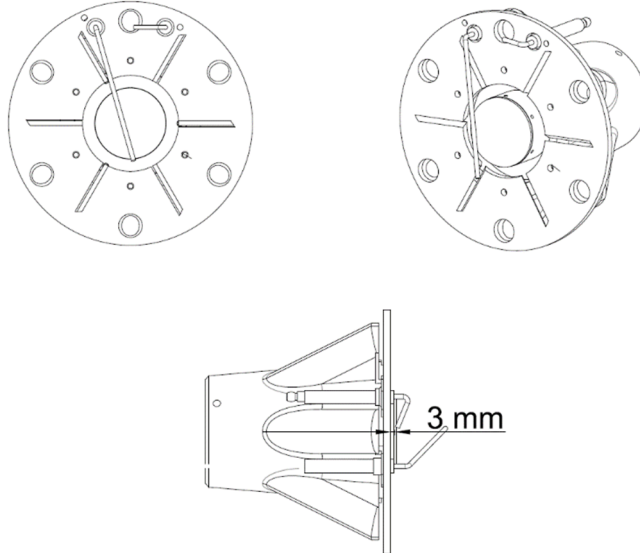

Electrical Connection

Perform electrical connections according to the diagram provided with the burner. Follow general security rules during installation of electric wiring and making connections. Connect the earthing terminal in electric panel to the earthing installation.

8.2. General Controls



Make sure to perform the following controls before commissioning the burner.

- Are the electrical connections correct?
- Is there electricity current?
- Is there gas?
- Has the heating system been filled with water?
- Is the thermostat set at the required temperature?
- Has the boiler explosion lid been controlled?
- Is there sufficient air in boiler room (ventilation section $\text{cm}^2 = \text{boiler capacity kW} \times 7$)
- Has the boiler been installed correctly? Has the boiler cover been closed properly?
- Has the air of the gas line been removed? Has a sealing test been made?

Operation of two-stage burner

- Open the main gas valve, check the gas pressure from the manometer at the valve. (max.300 mbar)
- Check the boiler thermostat or pressure switch settings.
- Bring the operating switch on the burner panel to position 2.
- Burner fan motor will be activated.
- Ignition will take place at the end of pre-purge process.
- 3 sec. later, the gas valve will be opened and combustion will occur.
- Flame control system (ionization) will start flame control.
- Burner will switch to the second stage (max. capacity) according to the heat requirement.
- After the boiler water heated up or the boiler pressure has risen, the burner will turn off.

Operation of a modulating burner

- Open the main gas valve; check max 300 mbar gas pressure from the manometer.
- Open operating switch on the burner panel.
- Switch on the modulating control switch.
- Switch automatic-hand switch to automatic.
- Check the temperature and pressure set values from the modulating control unit.
- Ignition will take place at the end of pre-purge process.
- 3 sec. later, the gas valve will be opened and combustion will occur.
- Flame control system (ionization) will start flame control.
- In modulating burner, the burner goes into max. capacity according to the signal from the modulating control unit.
- When the boiler water temperature or steam pressure increase, the modulating control unit will cause burner to run with min. capacity.
- If the boiler water temperature or steam pressure increases despite the operation of burner with min. capacity, the modulating control unit will stop the burner.

8.3. Combustion Adjustment

8.3.1. Gas Adjustment

Follow the instructions of the valve manufacturer during installation, dismantling and adjustment of the gas valve

8.3.1.1. VGD 20 4011 - 5011 Series Gas Valve

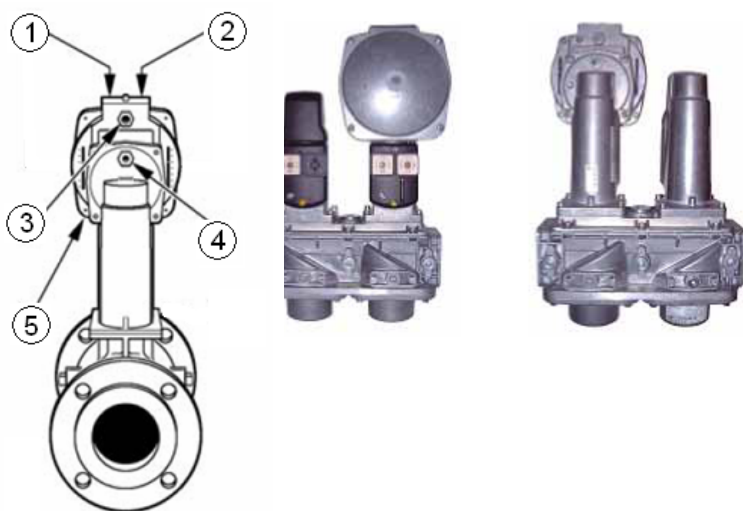

SKP 75 Connection Diagram

- 1 – Air-gas adjustment ratio
- 2 – Zero "0" point (start) adjustment
- 3 – Boiler counter pressure impulse connection
- 4 – Gas pressure impulse connection
- 5 – Air pressure impulse connection

8.3.1.2.MB DLE Series Monoblock Gas Valve

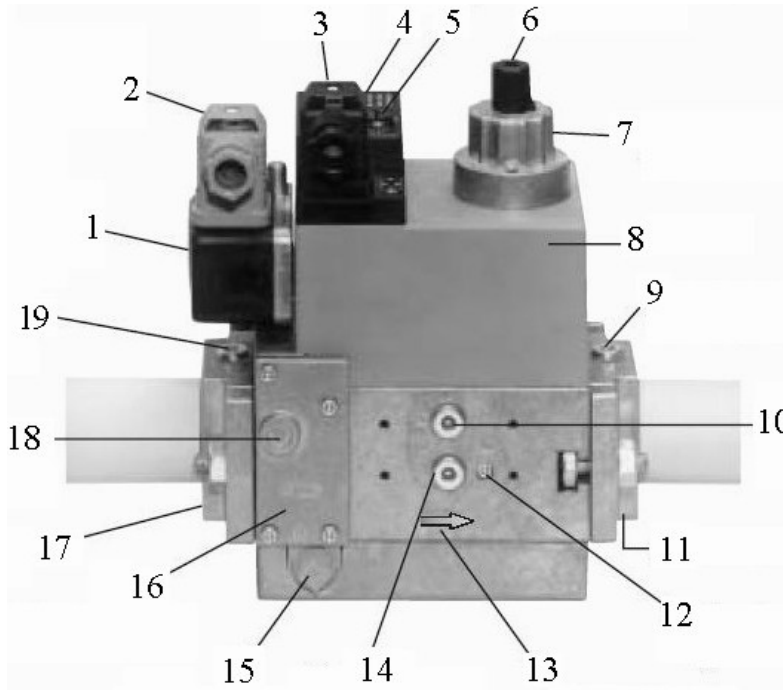

- 1- Pressure switch
- 2- Pressure switch electrical connection
- 3- Electrical connection of the valve
- 4- Operation gauge
- 5- The sealing ring
- 6- Set cover
- 7- Hydraulic disk brakes or settings
- 8- Coil
- 9- Measuring element connection (1/8)
- 10- Measuring element connection (1/8)
- 11- Output flange
- 12- Measuring element connection (1/8)
- 13- Gas flow way
- 14- Measuring element connection (1/8)
- 15- The vent plug
- 16- Filter chamber cover
- 17- Inlet flange
- 18- Measuring element connection (1/8)
- 19- Measuring element connection (1/8)



- Consider the below torque values for bolts tightened on the valve.
- Tighten flange bolts according to cross ordering and use proper tools.
- Sealing and function check must be performed if the valve is dismantled and re-installed over the line due to any reason.
- Before dismantling the valve from the line, you can perform filter replacement according to the below order.
 - o Cut off the gas flow (turn off the ball valve)
 - o Remove the 4 bolts (1,2,3,4) on the cover seen in the picture and take out the cover (5).
 - o Take the filter cartridge (6) out of its socket and replace with a new one
 - o Close the cover and tighten the bolts. In frequently performed filter replacement operations, use M4x14 bolt instead of self-tapping bolts used for fixing the cover.
 - o Perform sealing and function control

Max. torque values;

M 4	M 5	M 6	M 8	G 1/8	G 1/4	G 1/2	G 3/4
2,5 Nm	5 Nm	7 Nm	15 Nm	5 Nm	7 Nm	10 Nm	15 Nm

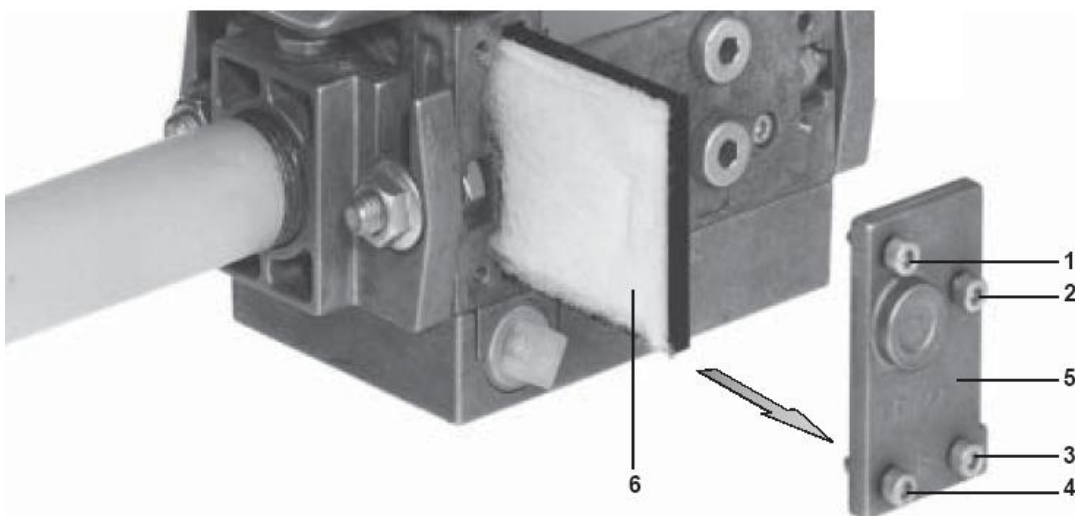

8.3.1.3.MB ZRD(LE) 415 – 420 Series Gas Valve

GasMultiBloc
Combined regulator and
safety shut-off valves
Two-stage function

MB-ZRD(LE) 415 - 420 B01

DUNGS®

7.26

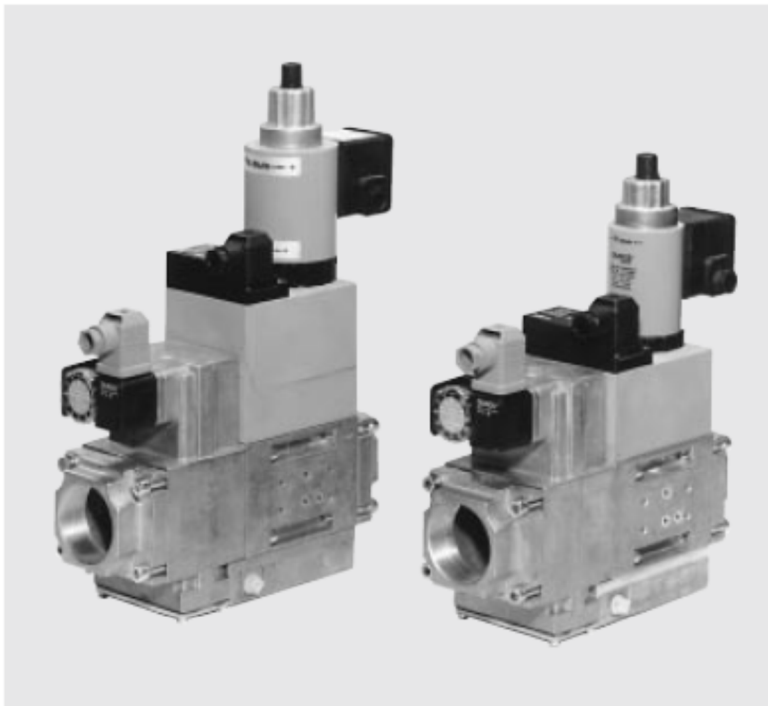

Technical description

The DUNGS GasMultiBloc integrates filter, regulator, valves and pressure switches in one compact fitting. Various designs are possible by the modular system:

- Dirt trap: microfilter
- One regulator and two main valves: B01
- One one-stage valve and one two-stage valve
- One valve is fast opening, one valve is slow or fast opening
- Solenoid valves up to 360 mbar as per DIN EN 161 Class A Group 2
- Sensitive setting of output pressure by proportional regulator as per DIN EN 88 Class A Group 2
- High flow rates with low pressure drop
- DC solenoid drive interference degree N
- Main volume restrictor and partial volume restrictor at valve V2
- Hydraulic opening delay
- Flange connections with pipe threads as per ISO 7/1
- Simple mounting, compact, light-weight

The modular system permits individual solutions by using external ignition gas tap in connection with separately controlled valves, by adding a valve proving system, mini/maxi pressure switches, pressure limiters, limit switch at valve V2.

Application

The modular system permits individual solutions in gas safety and regulator engineering. Suitable for gases of families 1, 2, 3 and other neutral gaseous media.

Approvals

EC type test approval as per EC Gas Appliance Directive:

MB-ZR...415-420 B01 CE-0085 AP 3156

EC type test approval as per EC Pressure Equipment Directive:

MB-ZR...415-420 B01 CE0036

Approvals in other important gas consum-

8.4. Air Pressure Switch Adjustment

While the burner is working without any problem, the air pressure switch is adjusted to desired minimum pressure as follows.

- Unscrew the screw of the transparent cover and remove the cover.
- Turn the adjustment wheel in the direction to increase the pressure, note the pressure value at which the burner is failed.
- Set the pressure switch to a value 1 mbar lower than the pressure value at which the burner failed and close the pressure switch lid.
- It is recommended that this adjustment is carried out when the burner is at minimum load.



8.5. Servomotor Adjustment

The amount of air is adjusted by means of the servomotor. The servomotor adjustment at two-stage and modulating burners is made by the cams on the servomotor.

- **SQN70-SQN30**

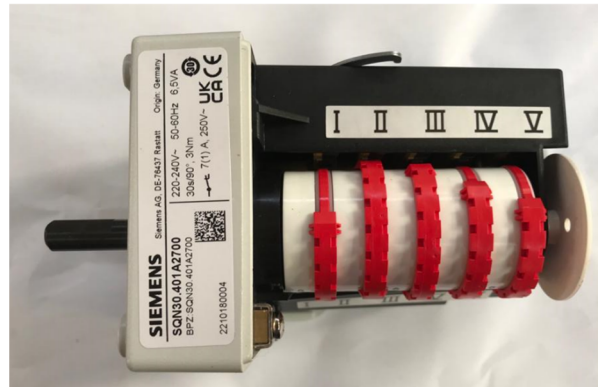
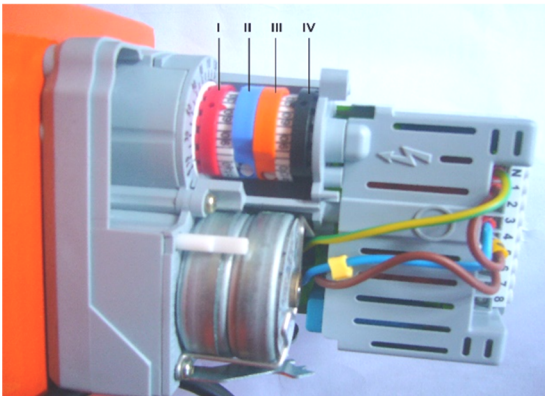

At Two-Stage Burners;

- I. Red Cam: Adjusts 2nd level max. air.
- II. Blue Cam: Resets the clamp.
- III. Orange Cam: Adjusts 1st level min. air.
- IV. Black Cam: Adjusts 2nd level valve opening degree.

At Modulating Burners;

- I. Red Cam: Performance max. air adjustment.
- II. Blue Cam: Resets the clamp.
- III. Orange Cam: Performs min. air adjustment.
- IV. Black Cam: Not used.



Do not open servomotor. Do not interfere with. It may damage servomotor or change burner settings.

8.6.Emission Measurement

In emission measurements, the following values are accepted as reference according to TS EN 676 +A2 standard.

- $\text{CO} < 100 \text{ mg/ kWh}$
- $\%3 \leq \text{O}_2 \leq \%5$
- $\text{NO}_x < 170 \text{ mg/ kWh}$
- Excess air ratio $1,2 \leq \lambda \leq 1,3$



It is important for the boiler to be sealed in order to avoid incorrect measurements during emission measurements.



Boiler temperature must be between 40 C° and 80 C° while making emission measurement in hot water boilers.

8.7.Capacity Adjustment

Exemplary Application:

Suppose the required burner capacity is (C) 2000 kW.

$H_u = 8250 \text{ kcal/m}^3$ (lower heating value)

$P = 860 \text{ kcal/kW}$ (Value of 1 kW in kcal)

$Q = C \times P$

$Q = 2000 \times 860 = 1720000 \text{ kcal/h}$

$V = Q / H_u$

$V = 1720000 / 8250 = 208.48 \text{ m}^3/\text{h}$

Set the required gas flow rate over the valve and check this value on the gas counter. Should there be no gas flowmeter in the system, set the burner by using the gas tip lost pressure diagram given at page 20-21-22.



In order to ensure the emission values set the air klappe in each gas flow increase.

8.8. Burner Control System

The burner control system SIEMENS LME7... is a microprocessor-based burner control with matching system components for the control and supervision of forced draft burners of medium to high capacity.

LME7... are used for the startup and supervision of 1- or 2-stage forced draft gas burners in intermittent operation. The flame is supervised with an ionization probe, optionally with UV flame detector QRA2..., QRA4.U or QRA10....

- Burner control to EN 298: 2003
- For forced draft gas burners to EN 267 and EN 676

Integrated in the LME7... basic unit are:

- Burner control
- BCI
- Only LME72... / LME73...: Control for one actuator
- Lockout reset button (info button)
- 3 multicolor signal lamp LED for operations and fault notifications
- Optional: Analog inputs for load controller DC 0...10 V, DC 0 / 4...20 mA, 0...135 Ω
- 3 x 7-segment display for service, fault and operating state information
- Interface for program module

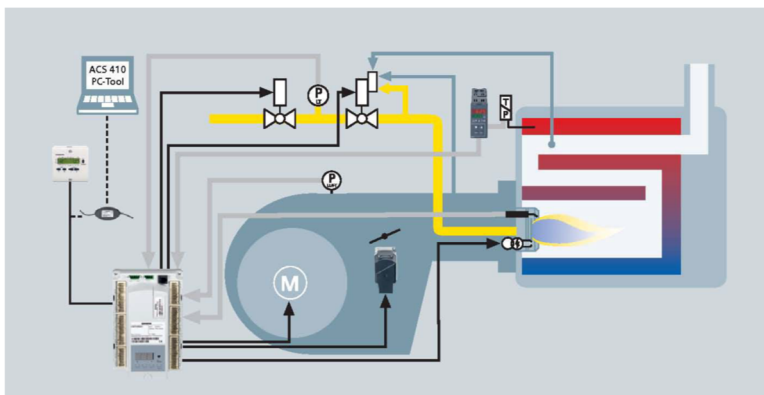

8.8.1. Inputs and Outputs / Internal Connection Diagram

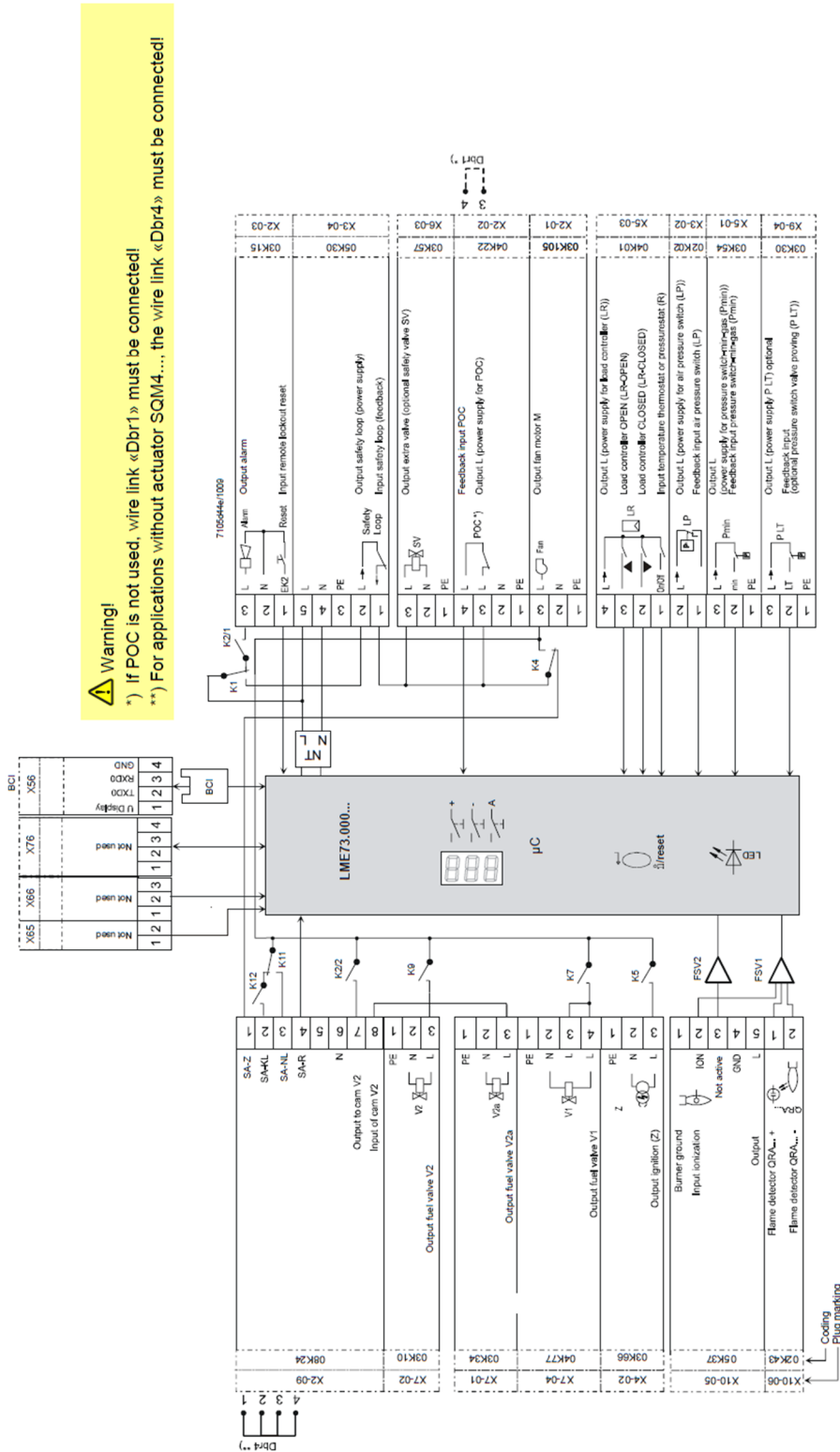

8.8.2. Error code list with operation via internal led

Error code	Clear text	Possible cause
bAC Er3	Fault of compatibility program module to basic unit during backup process	Program sequence of program module does not match the basic unit
Err PrC	Fault of program module	- Error in data content of program module - No program module fitted
Loc: 2	No establishment of flame at the end of safety time (TSA)	- Faulty or soiled fuel valves - Faulty or soiled flame detector - Poor adjustment of burner, no fuel - Faulty ignition equipment
Loc: 3	Air pressure faulty (air pressure switch (LP) welded in no-load position, decrease to specified time (t10) (air pressure switch (LP) response time)	Air pressure switch (LP) faulty - Loss of air pressure signal after specified time (t10) - Air pressure switch (LP) has welded in no-load position
Loc: 4	Extraneous light	Extraneous light during burner startup
Loc: 5	Air pressure faulty, air pressure switch welded in working position	Timeout air pressure switch (LP) - Air pressure switch (LP) has welded in working position
Loc: 6	Fault of actuator	- Actuator faulty or blocked - Faulty connection - Wrong adjustment
Loc: 7	Loss of flame	Too many losses of flame during operation (limitation of repetitions) - Faulty or soiled fuel valves - Faulty or soiled flame detector - Poor adjustment of burner
Loc: 8	---	Free
Loc: 9	---	Free
Loc: 10	Error not relatable (application), internal error	Wiring error or internal error, output contacts, other faults
Loc: 12	Valve proving	Fuel valve 1 (V1) leaking
Loc: 13	Valve proving	Fuel valve 2 (V2) leaking
Loc: 14	POC error	Error valve closure control POC
Loc: 20	Pressure switch-min-gas open	Gas shortage
Loc: 22	Safety loop open	- Pressure switch-max-gas open - Safety limit thermostat cut out
Loc: 60	Analog power source 4...20 mA, I <4 mA	Wire breakage
Loc: 83	PWM fan faulty	- PWM fan does not reach the target speed within the preset period of time, or - After reaching the target speed, the PWM fan leaves the tolerance band again (P650) for a time exceeding the tolerance time speed deviation (P660)
Loc: 138	Restore process successful	Restore process successful
Loc: 139	No program module detected	No program module plugged in
Loc: 167	Manual locking	Manual locking
Loc: 206	AZL2... incompatible	Use the latest version
Loc: 225	PWM fan faulty	- Fan speed dropped below the minimum prepurge PWM (P675.00) after reaching the prepurge speed, or - After reaching the ignition load speed, the maximum ignition load PWM (P675.01) was exceeded





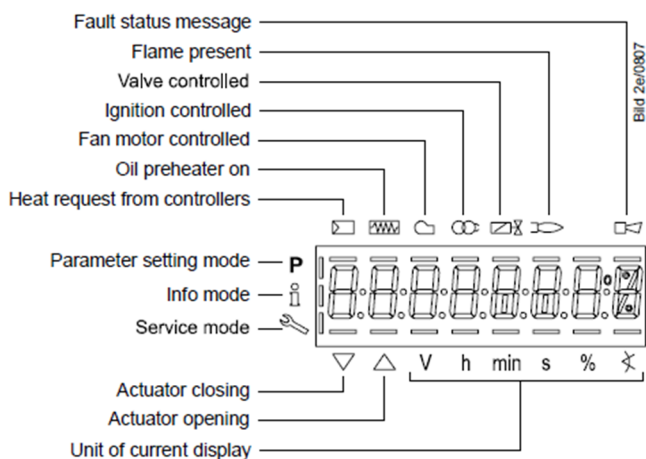
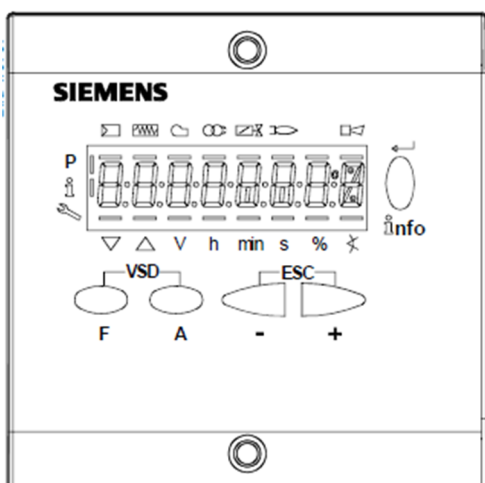





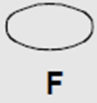



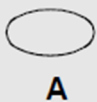



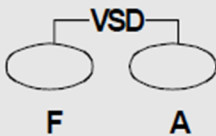

Error code	Clear text	Possible cause
Loc: 226	PWM fan faulty	Parameterization error: - Speed low-fire > speed high-fire, or - Low-fire = 0 rpm, or - Maximum speed = 0 rpm
Loc: 227	PWM fan faulty	One or several parameters violate the minimum / maximum limit
rSt Er1	Error in compatibility program module to basic unit during restore process	- Program sequence of program module does not match the basic unit
rSt Er2	Error in compatibility program module to basic unit during restore process	- Hardware of basic unit does not match the program module
rSt Er3	Error during restore process	- Program module faulty - Program module removed during restore process

8.8.3. Operating Control and Displays (Optional Usage)

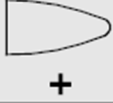
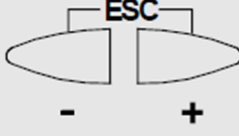

Display of operating states, program phases and fault codes

- Setting of parameters and ratio curves
- 8-digit LCD with bars
- LCD with backlit (support dependent on respective burner control)
- 5 multifunction buttons with reset facility
- Housing designed for wall mounting
- Degree of protection IP40 when mounted
- BCI interface
- Prepared for extra fault indication via LED (on request)
- Backup / restore function with specific types of burner controls (on request)

Button	Function
	F button - For driving the fuel actuator to another position (keep  depressed and adjust the value by pressing  or )
	A button - For driving the air actuator to another position (keep  depressed and adjust the value pressing  or )
	F and A buttons - For changing to parameter setting mode P (press simultaneously  and  plus  or ) - For readjusting the speed of the VSD operation (press  and  with  or  simultaneously)
	Info and Enter button - For navigating in info and service mode * Incrementing the selection (flashing symbol) (press button for <1 s) * Going one menu level down (press button for 1...3 s) * Going one menu level up (press button for 3...8 s) * Changing to operating mode (press button for >8 s) - Enter in parameter setting mode - Reset in the event of fault - One menu level down
	- button - For decreasing the value - For navigating during curve adjustments in info and service mode
	+ button - For increasing the value - For navigating during curve adjustments in info and service mode
	- and + buttons: Escape function (press  and  simultaneously) - No adoption of value - One menu level up



If the value measure from PL point is below 0.5 bar, set the impulse pipe as follows.

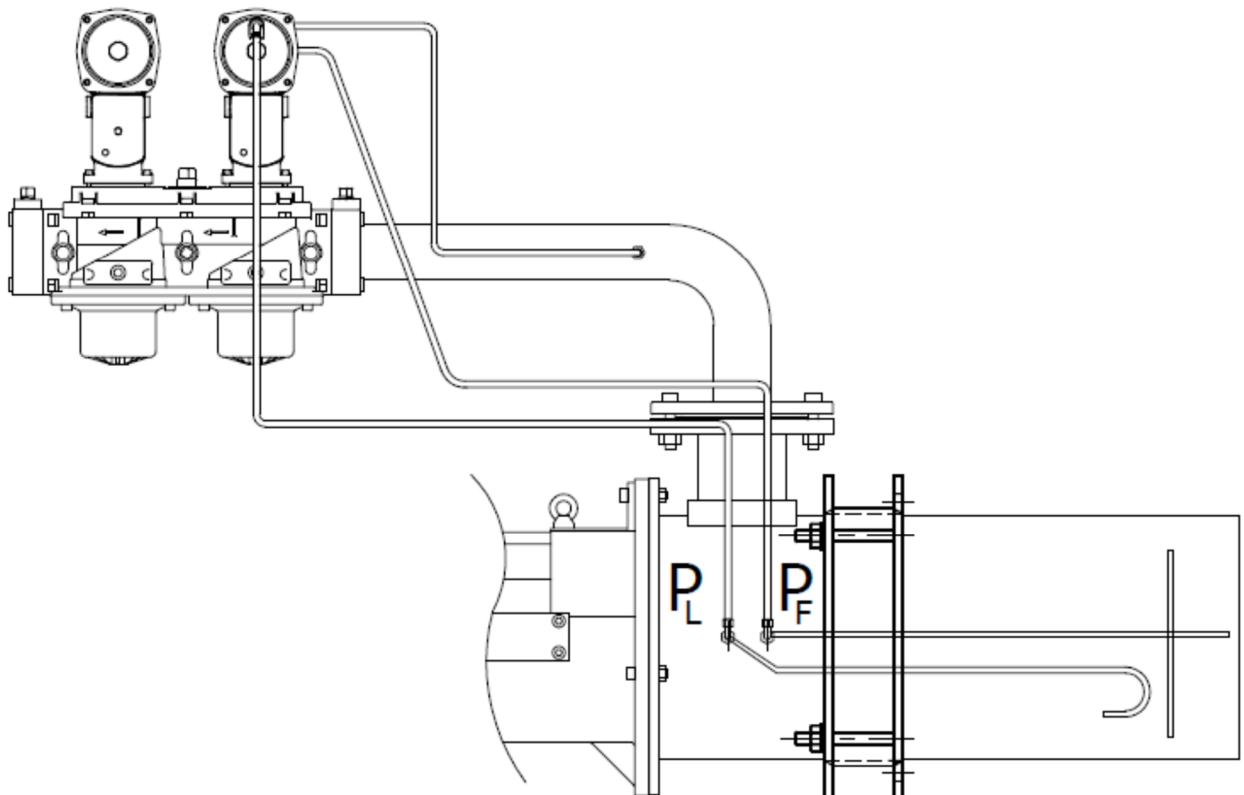
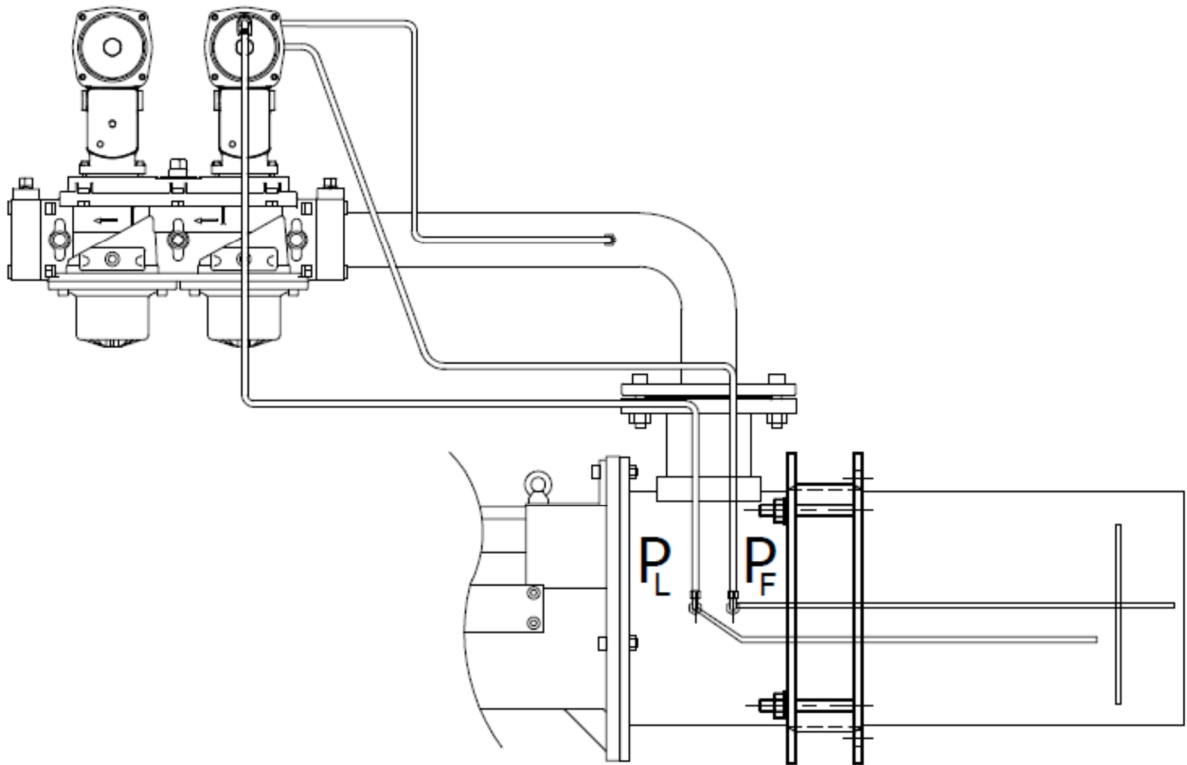

8.9. Gas Pass Equipment Required in Gas Line

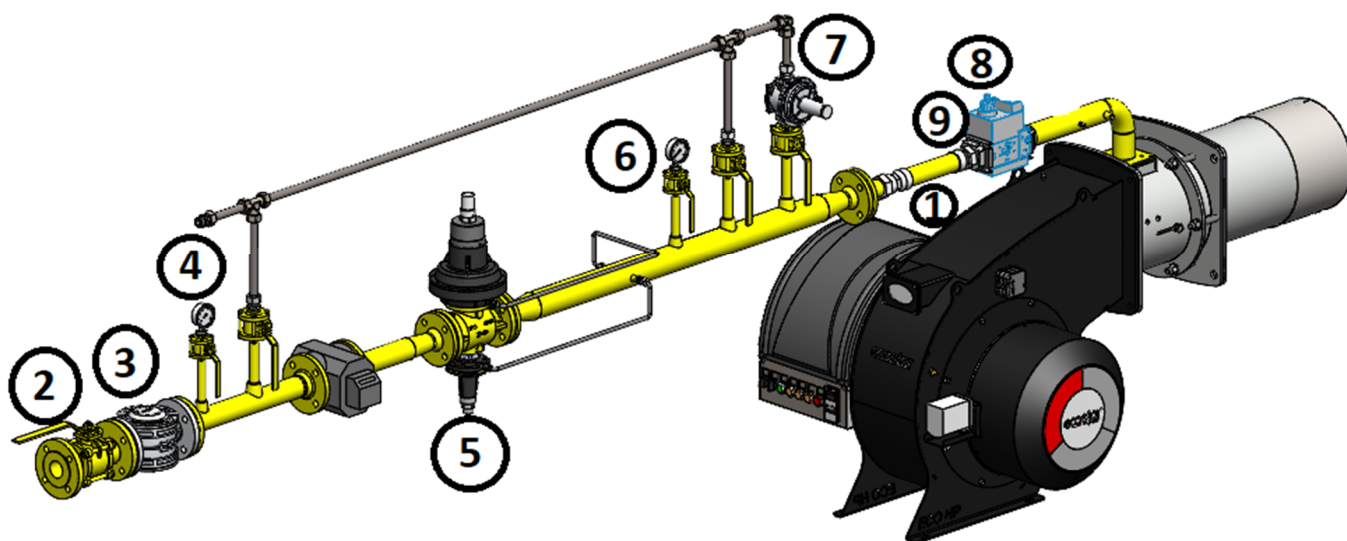

Pe < 300 mbar Q<1200kW	Pe > 300 mbar Q<1200kW	Pe < 300 mbar Q>1200kW	Pe > 300 mbar Q>1200kW
1- Compensator	1- Compensator	1- Compensator	1- Compensator
2- Ball valve	2- Ball valve	2- Ball valve	2- Ball valve
3- Gas filter	3- Gas filter	3- Gas filter	3- Gas filter
4- Inlet manometer + valve	4- Inlet manometer + valve	4- Inlet manometer + valve	4- Inlet manometer + valve
8 – Multi-block (safety and operation solenoids)	5- Regulator	8 – Multi-block (safety and operation solenoids))	5- Regulator
9- Sealing Control Set	6- Outlet manometer + valve	9- Sealing Control Set	6- Outlet manometer + valve
	7- Safety discharge valve		7- Safety discharge valve
	8 – Multi-block (safety and operation solenoids)		8 – Multi-block (safety and operation solenoids)
	9- Sealing Control Set		9- Sealing Control Set



Threaded and flanged connections may vary depending on the gas pressure and consumption.

9. MAINTENANCE

9.1. Monthly Maintenance

Monthly maintenance is a comprehensive process where general checks of burner and peripheral components are performed to prevent possible faults. After completion of maintenance and adjustment processes, make sure to perform an emission analysis.

- Clean the filters on the main line and multiblock.
- Check the burner gas tip.
- Perform insulation measurements of ignition and ionization electrodes, replace electrodes should there be leakage to the body.
- Check ignition cables and sockets.
- Check all wiring points. Tighten loose connections.
- Clean the dust and layers accumulated on the fan and air klappes.
- Check gas line pressure, it must be the same with the first adjusted pressure, otherwise burner load and emission values will also have changed.
- Check all bolts of the burner. Tighten loose bolts.
- After starting the burner and adjusting air klappe, perform flue gas emission measurement and check if there is an ideal combustion.

9.2. Seasonal Maintenance

Comprehensive maintenance work when the burner is re-started after long periods of shut-down or interruptions. After completion of maintenance and adjustment processes, make sure to perform a combustion analysis.

- Check insulation resistance of electric motor.
- Replace ignition and ionization electrodes with new ones.
- Clean air fan and clamps.
- Check the operating function.
- Check boiler thermostats.
- Check cleanliness of boiler inside and clean if necessary.



Follow installation directions during maintenance.

10. TROUBLESHOOTING

Problem	Cause	Explanation-Suggestion
Burner cannot be commissioned	Gas is cut or does not come	Gas valve might be closed. Open the valve.
	Fuse failure	Check burner power supply. The fuse on the main panel or the fuse on the burner might be tripped.
	Relay failure	Reset the thermal relay. Check adjustment of the thermal relay according to the current in motor label. If the failure is not removed, replace the thermal relay.
	Boiler thermostat, pressure switch failure	If there is a problem with the burner thermostats, pressure switches and steam tank this may be due to an unadjusted or faulty water level device; adjust it and if broken, replace it.
Flame appears and goes into failure mode.	Gas pressure error	Supply gas pressure might be low.
	Ionization electrode failure	Ionization electrode may be faulty or contaminated. Remove and clean.
	Program relay failure	Replace it with a new one.
Burner starts up, but fails after 10 seconds.	Air pressure switch adjustment	Air pressure switch might be adjusted to a high value. There may be dirt in the air pressure switch. Air pressure switch might be broken.
	Program relay failure	Replace it with a new one.
	Fan motor failure	Check fan motor coils, motor contactor and outlet from program relay.
Burner starts up, but fails after 30 seconds.	Gas valve, gas pressure drop	Gas valve might be closed. Supply gas pressure might be low. Check gas inlet manometer.
	Ignition electrode failure	Ignition electrodes might be misadjusted or ignition cables might have come out of their terminals. Adjust ignition electrodes with a distance of 3-5 mm. between them.
	Gas valve adjustment	Check the starting setting of the gas valve. Burner must be adjusted to sufficient start gas flow for its activation.
Boiler cover is overheating.	Sealing problem	Ensure sealing between the boiler cover and burner. If required, use insulating material between the boiler connecting flange and boiler cover.

12. AFTER-SALES SERVICES

Dear Customer,

We believe that providing a good service is as important as providing a good product. Therefore, we continue offering wide range of comprehensive services to our conscious customers.

For your suggestions, complaints and service requests

Esentepe Mah.Milangaz Cad. No:75 K:3

Kartal Monumento Plaza

KARTAL/İSTANBUL/TÜRKİYE

Tel: 444 8 326

Fax: +90 216 370 45 03

Factory Contact Details

Türkgücü OSB

Bülent Ecevit Bulvarı No:11

ÇORLU/TEKİRDAĞ/TÜRKİYE

Tel: +90 282 685 44 80-81

Fax: +90 282 685 42 09

Also you can contact with us:

Web site : www.ecostar.com.tr

E - mail : servis@ecostar.com.tr



Please observe the following recommendations.

- Use the product in accordance with the principles of this manual.
- For any service demands regarding the product, please contact our Service Center from the abovementioned phone numbers.
- Upon your purchase, register your warranty certificate during installation.

