

MONOBLOCK LIGHT OIL BURNERS INSTALLATION, OPERATING AND MAINTENANCE MANUAL

TWO-STAGE AND MODULATING OPERATION

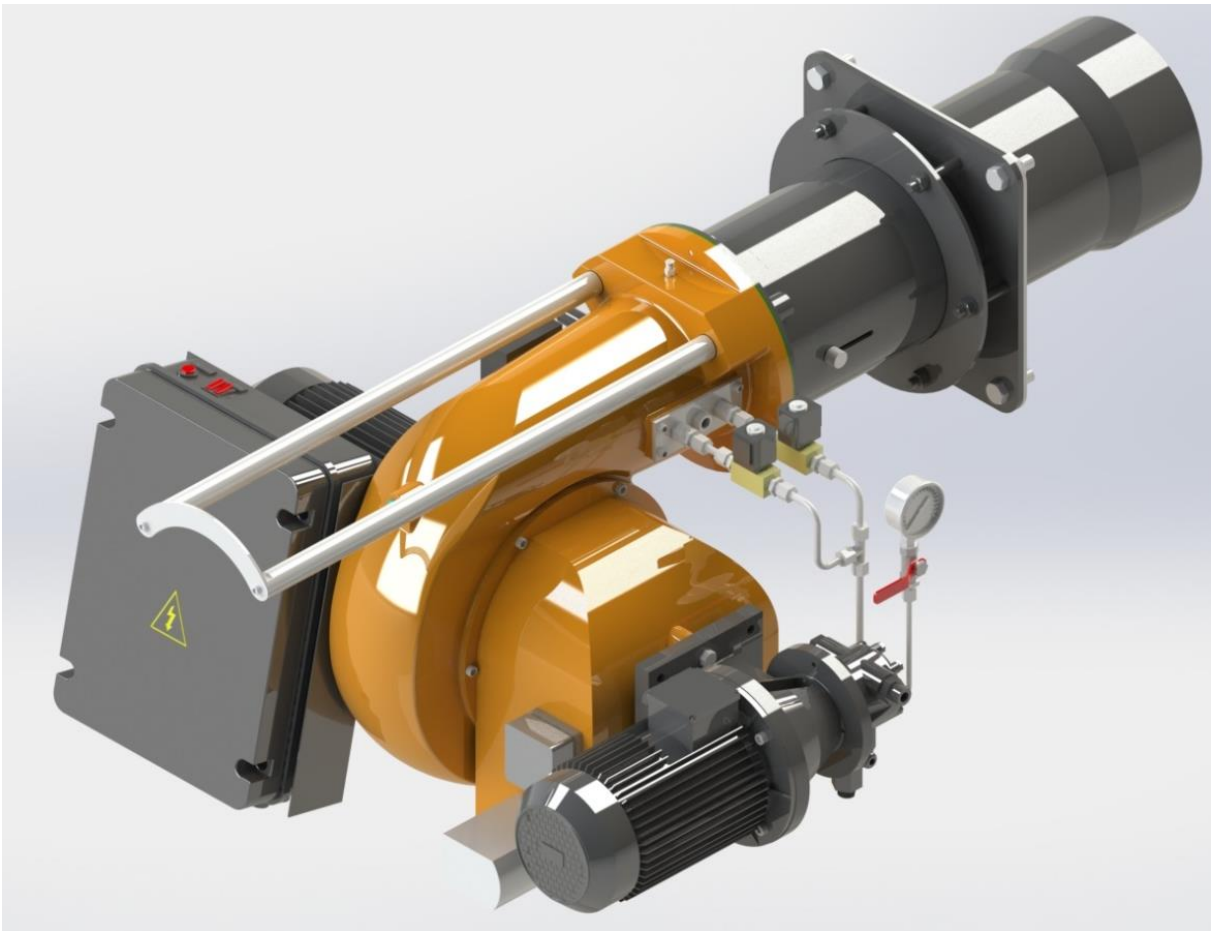

ECO 50
ECO 55
ECO 60
ECO 65
ECO 70
ECO 75



DEAR USER,

ECOSTAR ECO 50, ECO 55, ECO 60, ECO 65, ECO 70, ECO 75 Light Oil burners are prepared and manufactured according to the latest technical developments and safety rules. It is easy to use for our customers.

We recommend that you read this manual and safety warnings thoroughly before the use of the device in order to ensure safe, cost effective and environmental-friendly use.

If you encounter any issue that is not explained clearly in this manual or you could not understand, please contact with our service department.

We thank you for choosing ECOSTAR brand.

Ecostar LIGHT OIL Burners are manufactured in accordance with TS EN 267 standards.





This Operating Manual is an integral part of the burner and must be maintained in a plastic dossier and hung at a clearly visible place in the burner room.

CONTENTS

1. WARNINGS	3
1.1. Warning Symbols and Descriptions	3
1.2. General Safety Rules	4
2. TERMS OF WARRANTY	6
2.1. Out of Warranty Conditions	6
3. BURNER'S GENERAL FEATURES	7
3.1. Purpose of Use and Work Limits of Burners	7
3.2. Code Key	7
3.3. Burner Components	9
4. FLUE GAS AND HEATING WATER SCHEMA	31
5. TECHNICAL DATA	32
5.1. Capacity Table	32
5.2. Back Pressure-Capacity Diagrams	33
5.3. Burner Dimensions	34
5.4. Flame Length and Diameter	35
5.5. Noise Level	35
6. BURNER HANDLING INFORMATION	35
7. INSTALLATION	37
7.1. Burner Installation Picture	37
7.2. In reverse flame front mirror boilers	38
7.3. In cylindrical (straight flame) boilers	38
8. COMMISSIONING	39
8.1. Before Commissioning	39
8.2. General Controls	39
8.3. Combustion Adjustment	40
8.4. Fuel Pumps	40
8.5. Servomotor Adjustment	44
8.6. Emission Measurement	49
8.7. Program Relay	49
8.8. Light Oil Burner Fuel Ring Line	51
9. MAINTENANCE	52
9.1. Weekly Maintenance	52
9.2. Monthly Maintenance	52
9.3. Seasonal Maintenance	53
9.4. Installation and Disassembly Instructions for Maintenance Purposes	54
10. TROUBLESHOOTING	55
11. PERIODICAL FLUE GAS MEASUREMENT REPORT	56
12. AFTER-SALES SERVICES	57
13. NOTES	58

1. WARNINGS

1.1. Warning Symbols and Descriptions

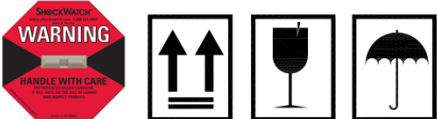
Symbols	Symbol Descriptions
	Important information and useful hints.
	Warning of danger to life or property.
	Warning of electrical voltage.
	Product handling information.
	Electric motor direction of rotation
	Carry in an upright position. Fragile Item. Protect against water.

1.2. General Safety Rules

- All personnel engaged in installation, disassembly, commissioning, operation, control, maintenance and repair should have received the necessary training and fully read and understood this manual.
- No changes that might damage the safety of the burner unit must be made by persons and/or organizations on the burner unit.
- All operation, commissioning and installation works (except for burning adjustment) should be carried out when the burner is not operating and after disconnecting the power supply. Noncompliance with these rules may lead to serious bodily injuries and even death by electrical shocks or uncontrolled flame formation.
- Repairs concerned with safety elements should be carried out only by the manufacturing company.
- The device should never be used by children, mentally handicapped and inexperienced persons.
- Children must not be allowed to play with the device.
- Keep the device away from explosive and flammable materials.
- Device must intake air, ventilation and air discharge holes must not be closed.



Do not store any inflammable materials in boiler room.



Wear hearing protectors if there is noise in boiler room.



In case of fire or other emergency;

- Switch off the main switch
- Take appropriate actions



The burner installation must be carried out in accordance with the instructions. Vibration can damage the burner and its components.



Keep boiler doors closed while starting burner and during burner operation.



Check combustion values to be correct by using flue gas analyzer at the whole adjustment range between minimum, full load, and ignition load.



Use lifting device or belt for lifting fan motor, if necessary



During the first commissioning of the burner or in case of any revision carried out in the electrical system or motor cables by any reason, direction of the fan rotation must certainly be checked by the authorized technical service.



For products that have not been commissioned or started more than 6 months, before activating the servomotor;

In air dampers and oil regulators, servomotor and air damper connections must be checked to ensure that they are free running in spite of immobility and oil freezing.



BURNER ROOM

Install the burner in a suitable room/floor with minimum external air openings and sufficient to ensure perfect combustion, in compliance with current regulations.

Never obstruct air openings of the burner room, burner fan intake vents or air ducts in order to prevent:

- a. The build up of toxic / explosive gas mixtures in the burner room,
- b. Combustion with insufficient air, resulting in hazardous, anti-economical and polluting operation.

The burner must be always protected from rain, snow and frost to prevent corrosion and paint deformations.

Keep the burner room clean and free of solid volatile substances, which could be sucked into the fan and clog the internal burner or combustion head air ducts.

2. TERMS OF WARRANTY

Main and auxiliary equipment and all components used in Ecostar light oil burners are guaranteed for 1 year by TERMO ISI SİST. A.Ş starting from the date of commissioning under the maintenance, adjustment, operating conditions and relevant mechanic, chemical and thermal effects explained herein.



Please note that this warranty is only valid if the device(s) is commissioned and maintained by our authorized services.



Our company reserves the right to make any modifications on the product and all instructions thereof for improvement purposes.

2.1. Out of Warranty Conditions

- Any damage arising out of or in relation to customers' non-compliance to their responsibilities with regards to installation, commissioning, operation and maintenance,
- Any damage arising out of or in relation to commissioning, repairs and maintenance carried out by unauthorized services,
- Any damage that may occur during transportation or storage of the product,
- Not preserving the product in its original packaging until the installation stage,
- Incorrect and poor electrical connections, Failures due to incorrect voltage applications, frequent repetition of voltage fluctuations,
- Any damage that may occur as a result of incorrect fuel usage or, foreign substances in the fuel used or using of the product without any fuel,
- Any damage that may occur due to foreign particles entered into the product during installation and operation,
- Failures due to incorrect device selection,
- Any damage to unit due to natural disasters,
- Devices without any warranty certificates,
- Warranty Certificates without the stamp and signature of the authorized dealer or service,
- Devices with any falsification on the warranty certificate or without an original serial number.
- The risks during transportation of device under the responsibility of customer belong to the customer.
- Presence of misuse faults are indicated in the reports issued by authorized service stations or our authorized agent, dealer, representative or our factory in case of unavailability of authorized service stations.
- Customers may apply consumer protection arbitrator committee with regards to this report and request for an expert report.

3. BURNER'S GENERAL FEATURES

ECOSTAR light oil burners are designed to operate with oil at 2.5 – 6 Cst (mm²/s) viscosity, at rated capacity and pressure ranges and -15% to +10% nominal voltage.

3.1. Purpose of Use and Work Limits of Burners

- This product works at any load value equivalent to its max. capacity or covered by its capacity range;
 - In hot water and steam boilers,
 - In direct and indirect hot air generators,
 - Industrial appliances operating at temperature below 600 °C,
 - -15 °C...+60 °C ambient temperature range,
 - 1N 230 VAC/3N 380VAC /50 Hz feed voltage (-%15...+%10) values,
 - Max. 95% relative humidity,
 - In well-ventilated open and closed spaces compatible with protection class IP 40.



This device must never be operated with open flame!

3.2. Code Key

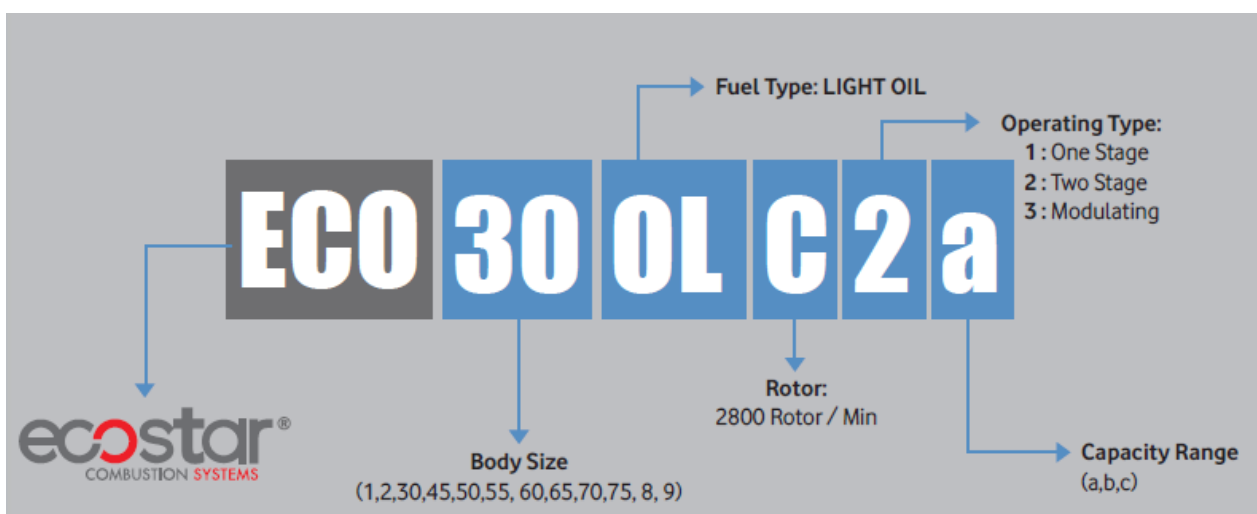

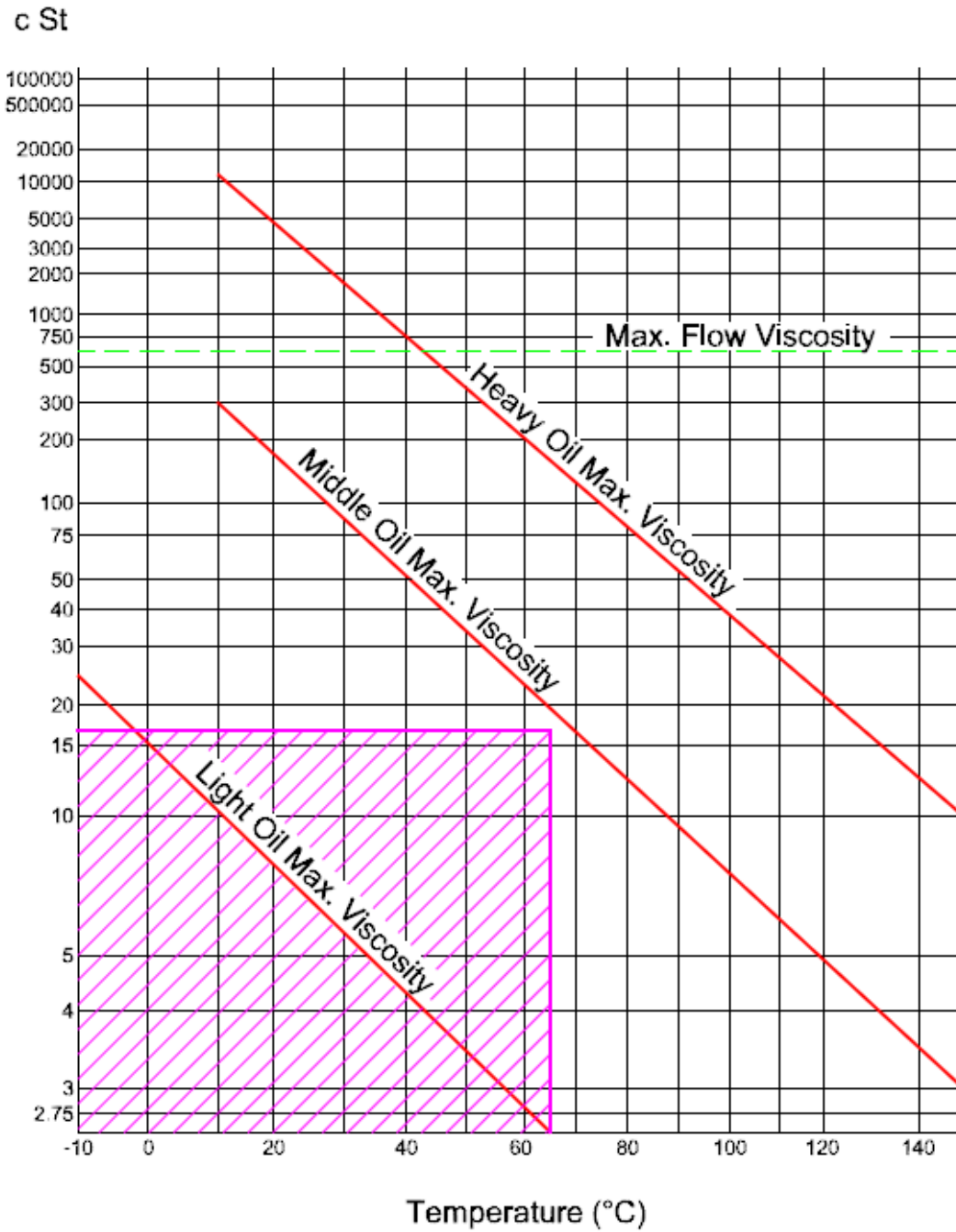

Temperature change of fuel used in ECOSTAR light oil burners dependent on viscosity



Operating Range

Assembly No	Part Name	Assembly No	Part Name
1	Body	19	Servomotor
2	Klingerit Gasket	20	Servomotor Coupling
3	Flame Tube	21	Air Damper
4	Flame Tube Extension	22	Air Damper
5	Gasket	23	Air Damper Motion Rod
6	Boiler Connection Flange	24	Air Damper Motion Transfer Rod
7	Fan	25	Fan Coupling
8	Fan Motor Connection Flange	26	Coupling Connection Pipe
9	Motor	27	Pump Coupling
10	Electrical Panel	28	Pump
11	Electrical Panel Mounting Plate	29	Fuel Pipe
12	Handling Shaft	30	Solenoid Valve
13	Shaft Fixing Plate	31	Lance
14	Observation Glass	32	Lance Centring Console
15	Ignition Transformer	33	Ignition Electrode
16	Transformer Connection Plate	34	Electrode Connection Sheet Metal
17	Photocell	35	Combustion Head
18	Purger	36	Fuel Nozzle

ECO 50 OLC3

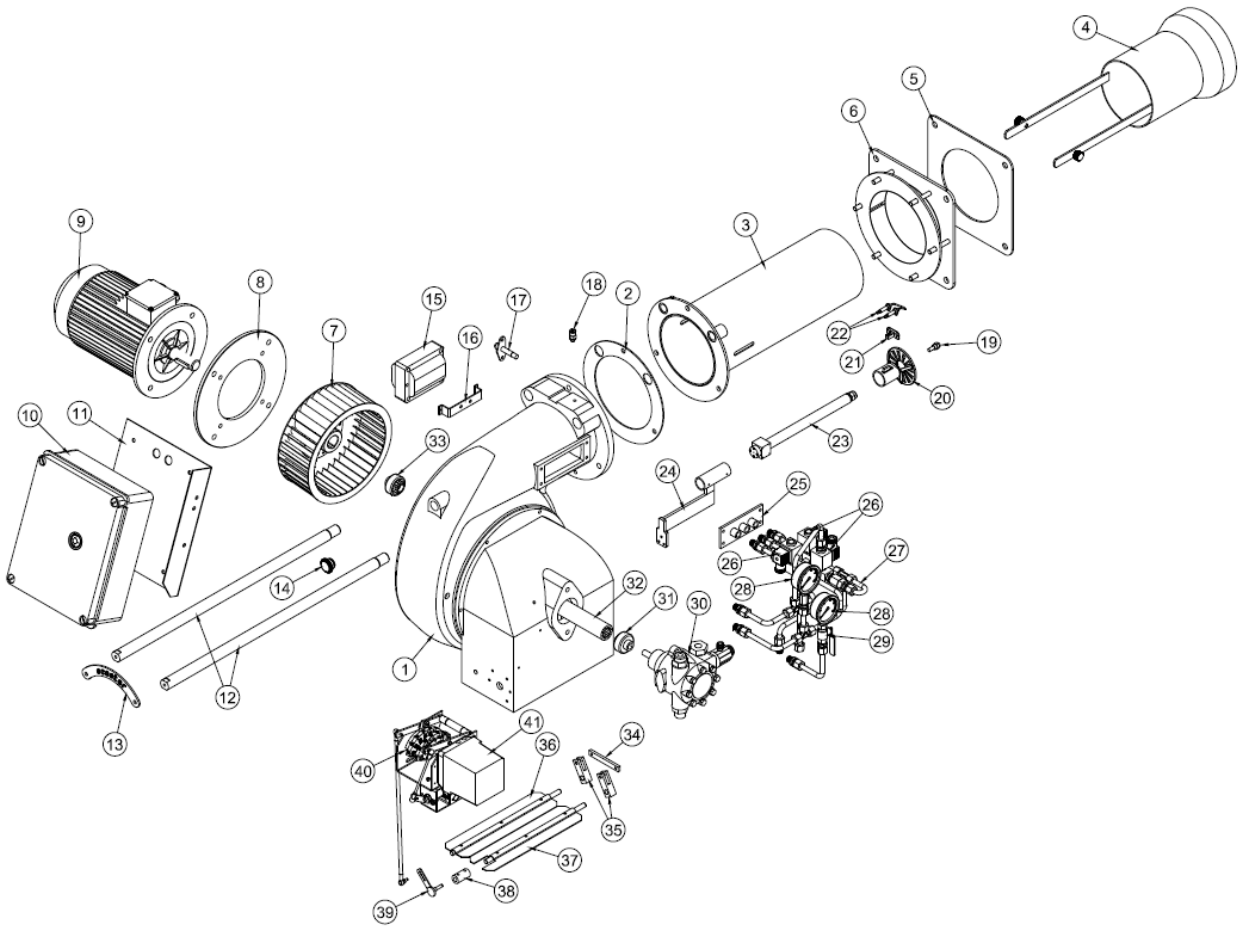

Assembly No	Part Name	Assembly No	Part Name
1	Body	22	Ignition Electrode
2	Klingerit Gasket	23	Lance
3	Flame Tube	24	Lance Centring Console
4	Flame Tube Extension	25	Solenoid Valve Connection Plate
5	Gasket	26	Solenoid Valve
6	Boiler Connection Flange	27	Fuel Pipes
7	Fan	28	Manometer
8	Fan Motor Connection Flange	29	Ball Valve
9	Motor	30	Pump
10	Electrical Panel	31	Pump Coupling
11	Electrical Panel Mounting Plate	32	Coupling Connection Pipe
12	Handling Shaft	33	Fan Coupling
13	Shaft Fixing Plate	34	Air Damper Motion Transfer Rod
14	Observation Glass	35	Air Damper Motion Rod
15	Ignition Transformer	36	Air Damper
16	Transformer Mounting Plate	37	Air Damper
17	Photocell	38	Coupling
18	Purger	39	Air Damper Adjustment Rod
19	Fuel Nozzle	40	Disc Control Group
20	Combustion Head	41	Servomotor
21	Electrode Connection Sheet Metal		

ECO 55 OLC2-2a

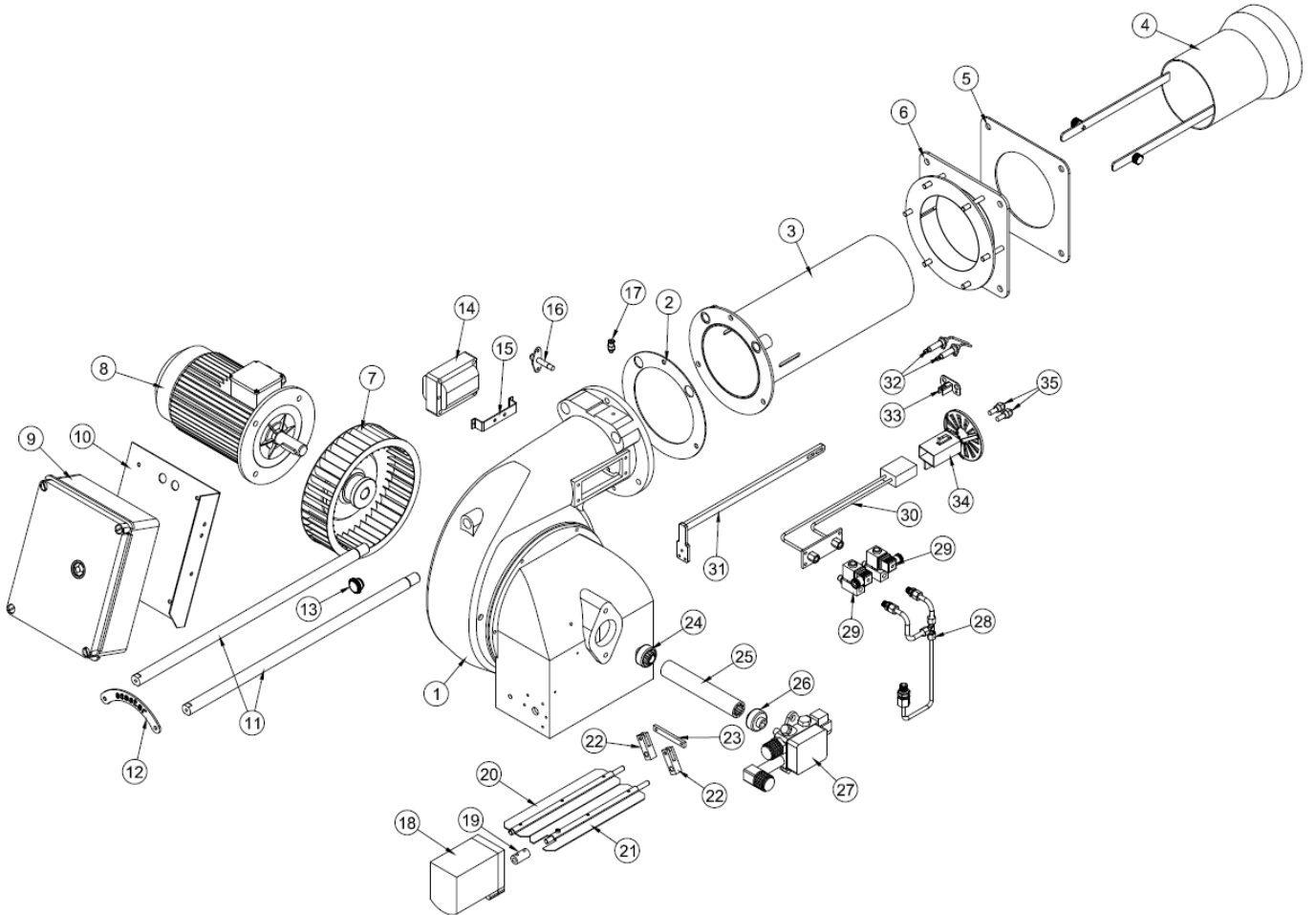

Assembly No	Part Name	Assembly No	Part Name
1	Body	19	Servomotor Coupling
2	Klingerit Gasket	20	Air Damper
3	Flame Tube	21	Air Damper
4	Flame Tube Extension	22	Air Damper Motion Rod
5	Gasket	23	Air Damper Motion Transfer Rod
6	Boiler Connection Flange	24	Fan Coupling
7	Fan	25	Coupling Connection Pipe
8	Motor	26	Pump Coupling
9	Electrical Panel	27	Pump
10	Electrical Panel Mounting Plate	28	Fuel Pipe
11	Handling Shaft	29	Solenoid Valve
12	Shaft Fixing Plate	30	Lance
13	Observation Glass	31	Lance Centring Console
14	Ignition Transformer	32	Ignition Electrode
15	Transformer Mounting Plate	33	Electrode Connection Sheet Metal
16	Photocell	34	Combustion Head
17	Purger	35	Fuel Nozzle
18	Servomotor		

ECO 55 OLC3-3a

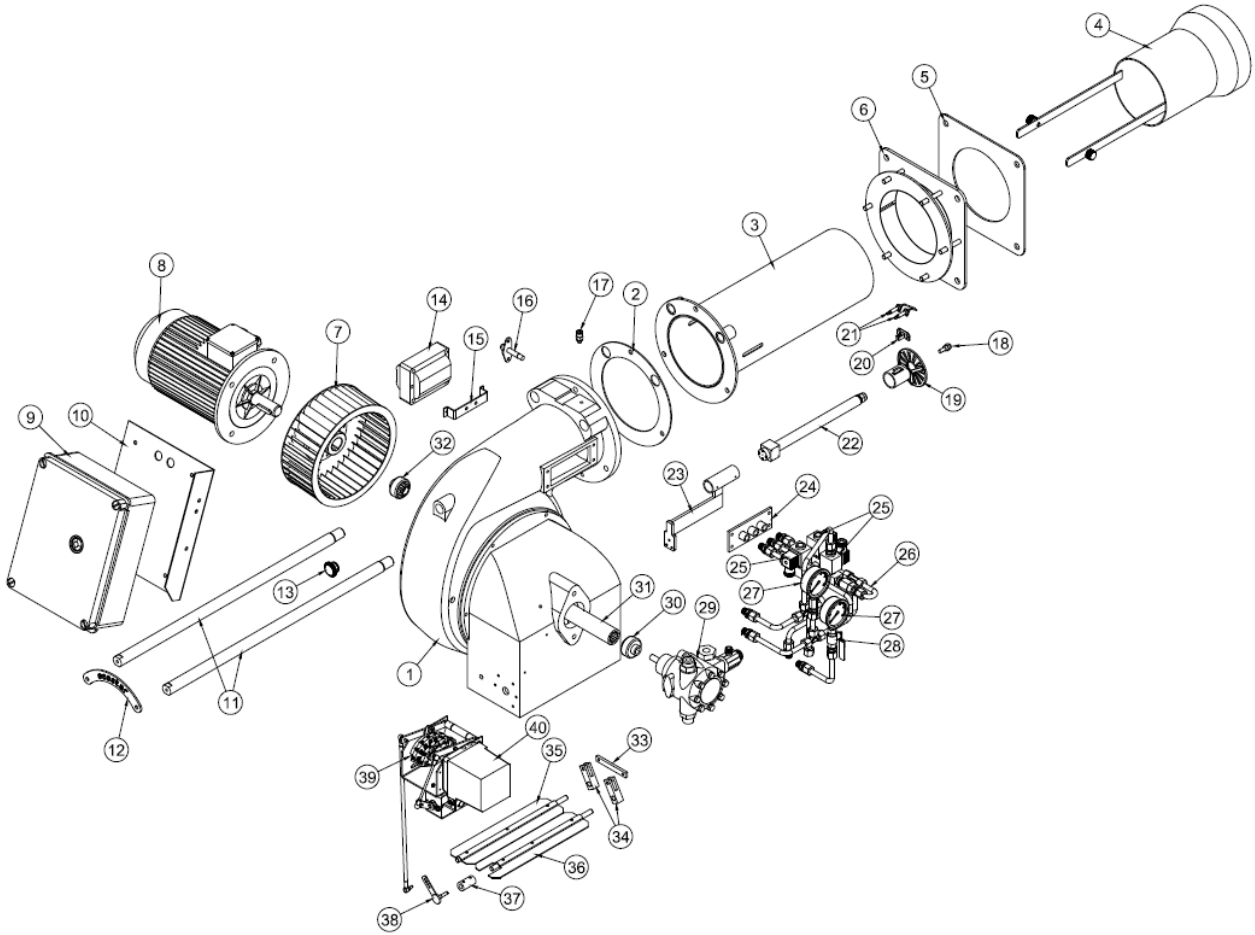

Assembly No	Part Name	Assembly No	Part Name
1	Body	21	Ignition Electrode
2	Klingerit Gasket	22	Lance
3	Flame Tube	23	Lance Centring Console
4	Flame Tube Extension	24	Solenoid Valve Connection Plate
5	Gasket	25	Solenoid Valve
6	Boiler Connection Flange	26	Fuel Pipes
7	Fan	27	Manometer
8	Motor	28	Ball Valve
9	Electrical Panel	29	Pump
10	Electrical Panel Mounting Plate	30	Pump Coupling
11	Handling Shaft	31	Coupling Connection Pipe
12	Shaft Fixing Plate	32	Fan Coupling
13	Observation Glass	33	Air Damper Motion Transfer Rod
14	Ignition Transformer	34	Air Damper Motion Rod
15	Transformer Mounting Plate	35	Air Damper
16	Photocell	36	Air Damper
17	Purger	37	Coupling
18	Fuel Nozzle	38	Air Damper Adjustment Rod
19	Combustion Head	39	Disc Control Group
20	Electrode Connection Sheet Metal	40	Servomotor

ECO 60 OLC2

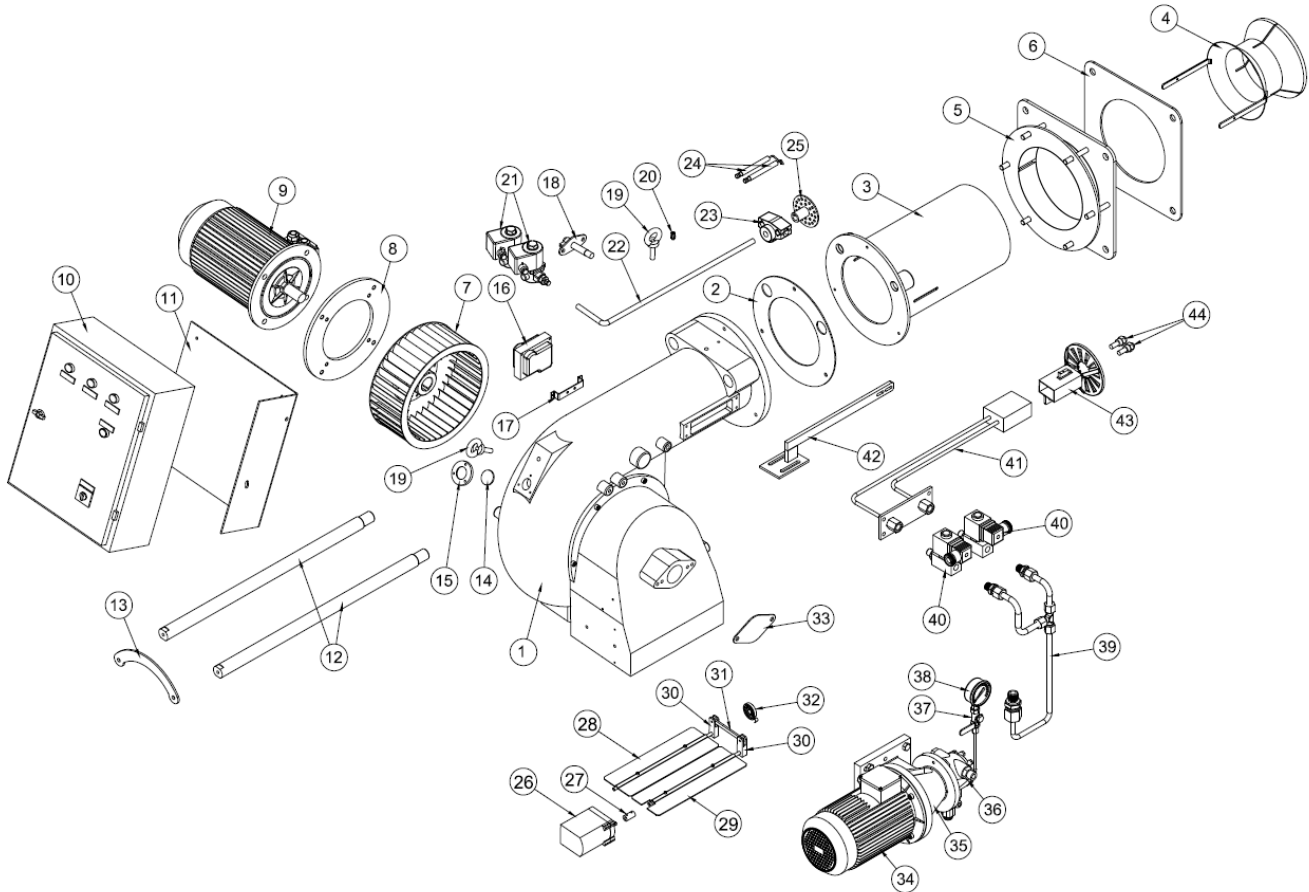

Assembly No	Part Name	Assembly No	Part Name
1	Body	23	Electrode Clamp
2	Klingerit Gasket	24	Pilot Ignition Electrode
3	Flame Tube	25	Pilot Combustion Head
4	Air Adjustment Mechanism	26	Servomotor
5	Boiler Connection Flange	27	Servomotor Coupling
6	Gasket	28	Air Damper
7	Fan	29	Air Damper
8	Fan Motor Connection Flange	30	Air Damper Motion Rod
9	Motor	31	Air Damper Motion Transfer Rod
10	Electrical Panel	32	Air Dumper Spring
11	Electrical Panel Mounting Plate	33	Pump Cover
12	Handling Shaft	34	Motor
13	Shaft Fixing Plate	35	Pump Motor Console
14	Observation Glass	36	Pump
15	Observation Frame	37	Ball Valve
16	Ignition Transformer	38	Manometer
17	Transformer Mounting Plate	39	Fuel Pipes
18	Photocell	40	Solenoid Valve
19	Eyebolt	41	Lance
20	Purger	42	Lance Centring Console
21	Gas Solenoid Valve	43	Combustion Head
22	Pilot Gas Pipe	44	Fuel Nozzle

ECO 60 OLC3

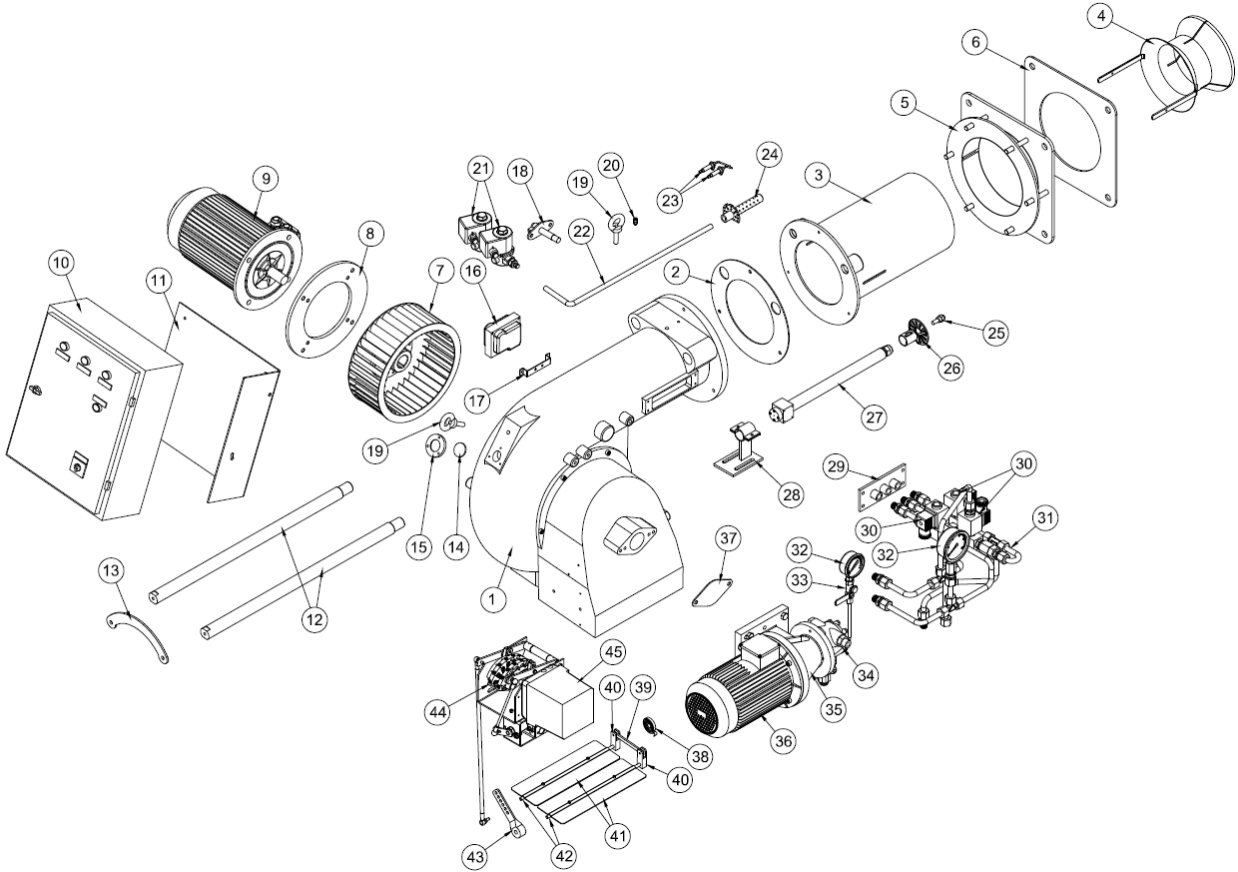

Assembly No	Part Name	Assembly No	Part Name
1	Body	24	Pilot Combustion Head
2	Klingerit Gasket	25	Fuel Nozzle
3	Flame Tube	26	Combustion Head
4	Air Adjustment Mechanism	27	Lance
5	Boiler Connection Flange	28	Lance Centring Console
6	Gasket	29	Solenoid Valve Connection Plate
7	Fan	30	Solenoid Valve
8	Fan Motor Connection Flange	31	Fuel Pipes
9	Motor	32	Manometer
10	Electrical Panel	33	Ball Valve
11	Electrical Panel Mounting Plate	34	Pump
12	Handling Shaft	35	Pump Motor Console
13	Shaft Fixing Plate	36	Pump Motor
14	Observation Glass	37	Pump Cover
15	Observation Frame	38	Air Damper Spring
16	Ignition Transformer	39	Air Damper Motion Transfer Rod
17	Transformer Mounting Plate	40	Air Damper Motion Rod
18	Photocell	41	Air Damper Plate
19	Eyebolt	42	Air Damper Shaft
20	Purger	43	Air Damper Adjustment Rod
21	Gas Solenoid Valve	44	Disc Console Group
22	Pilot Gas Pipe	45	Servomotor
23	Pilot Ignition Electrode		

ECO 65 OLC2

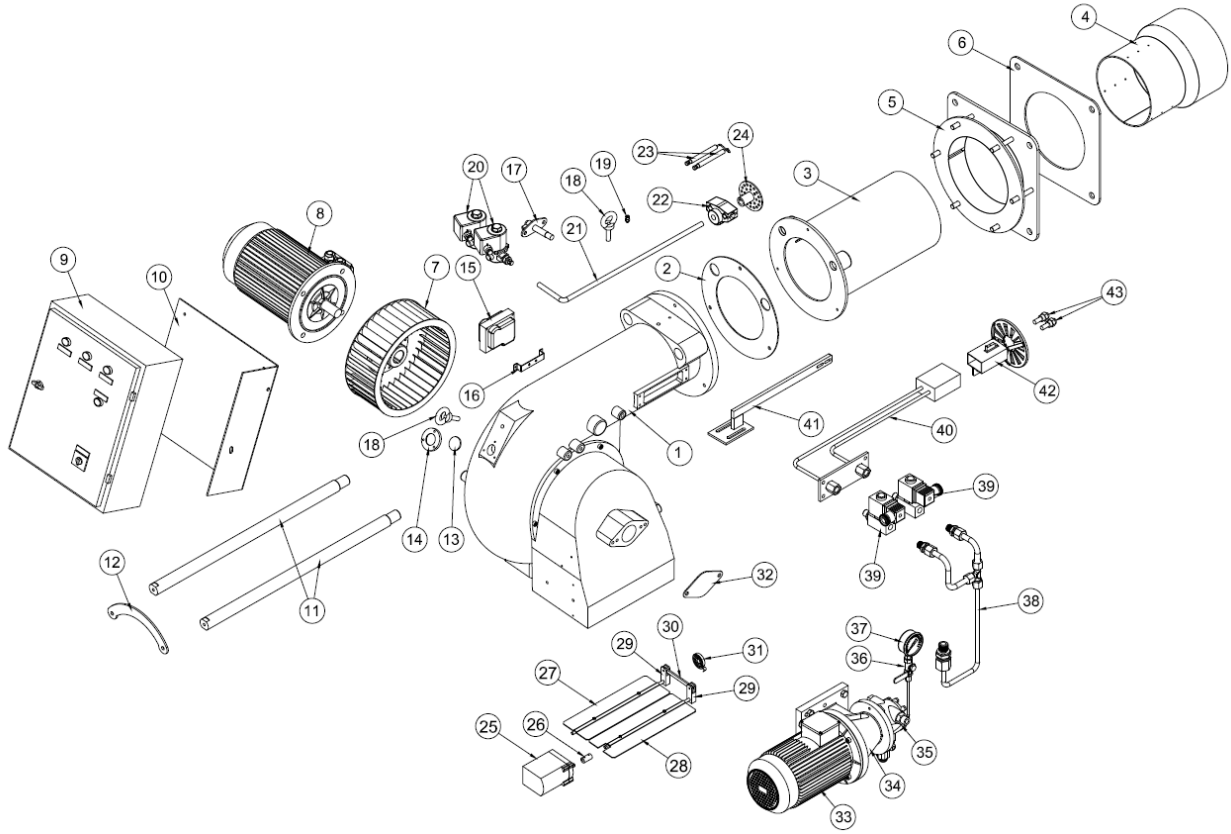

Assembly No	Part Name	Assembly No	Part Name
1	Body	23	Pilot Ignition Electrode
2	Klingerit Gasket	24	Pilot Combustion Head
3	Flame Tube	25	Servomotor
4	Air Adjustment Mechanism	26	Servomotor Coupling
5	Boiler Connection Flange	27	Air Damper
6	Gasket	28	Air Damper
7	Fan	29	Air Damper Motion Rod
8	Motor	30	Air Damper Motion Transfer Rod
9	Electrical Panel	31	Air Dumper Spring
10	Electrical Panel Mounting Plate	32	Pump Cover
11	Handling Shaft	33	Motor
12	Shaft Fixing Plate	34	Pump Motor Console
13	Observation Glass	35	Pump
14	Observation Frame	36	Ball Valve
15	Ignition Transformer	37	Manometer
16	Transformer Mounting Plate	38	Fuel Pipes
17	Photocell	39	Solenoid Valve
18	Eyebolt	40	Lance
19	Purger	41	Lance Centring Console
20	Gas Solenoid Valve	42	Combustion Head
21	Pilot Gas Pipe	43	Fuel Nozzle
22	Electrode Clamp		

ECO 65 OLC3

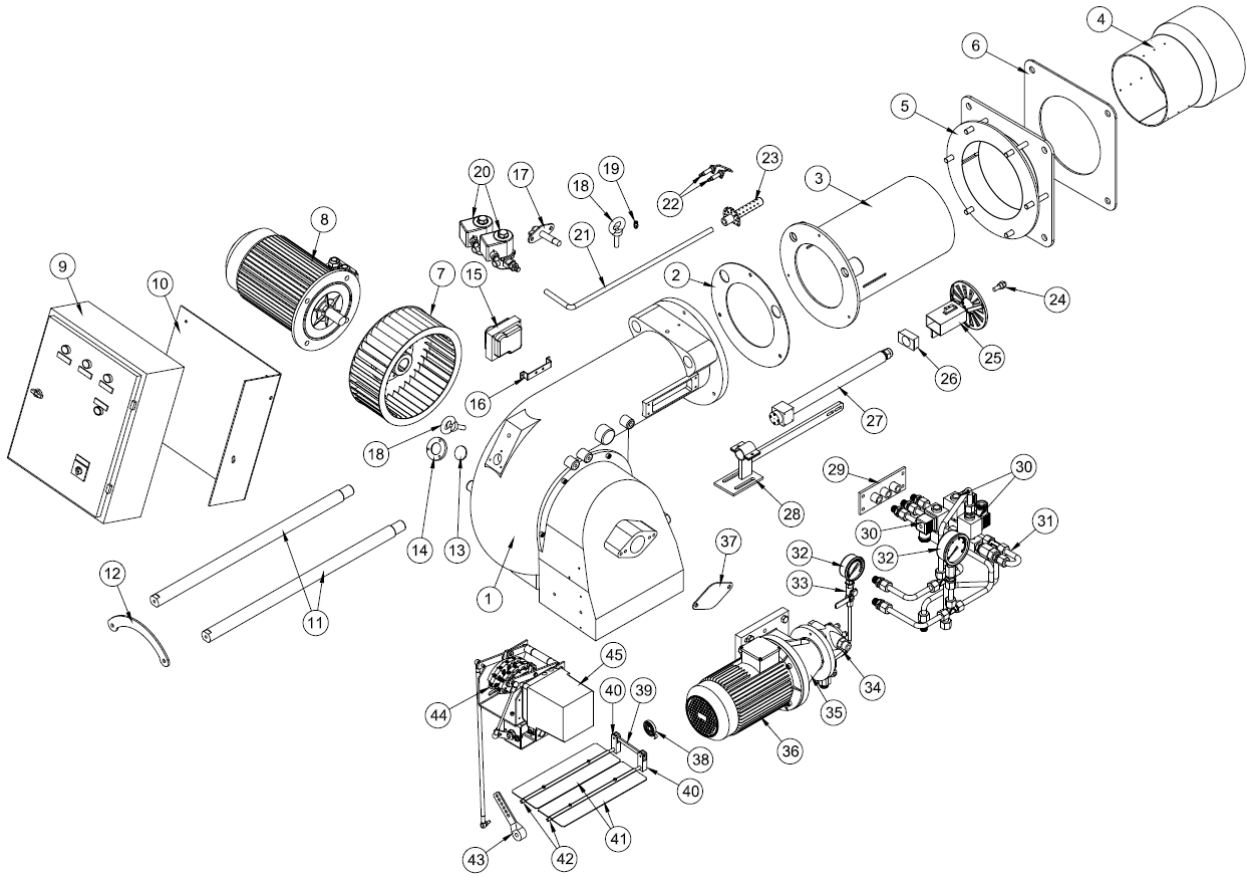

Assembly No	Part Name	Assembly No	Part Name
1	Body	24	Fuel Nozzle
2	Klingerit Gasket	25	Combustion Head
3	Flame Tube	26	Centring Wedge
4	Air Adjustment Mechanism	27	Lance
5	Boiler Connection Flange	28	Lance Centring Console
6	Gasket	29	Solenoid Valve Connection Plate
7	Fan	30	Solenoid Valve
8	Motor	31	Fuel Pipes
9	Electrical Panel	32	Manometer
10	Electrical Panel Mounting Plate	33	Ball Valve
11	Handling Shaft	34	Pump
12	Shaft Fixing Plate	35	Pump Motor Console
13	Observation Glass	36	Motor
14	Observation Frame	37	Pump Cover
15	Ignition Transformer	38	Air Damper Spring
16	Transformer Mounting Plate	39	Air Damper Motion Transfer Rod
17	Photocell	40	Air Damper Motion Rod
18	Eyebolt	41	Air Damper Plate
19	Purger	42	Air Damper Shaft
20	Gas Solenoid Valve	43	Air Damper Adjustment Rod
21	Pilot Gas Pipe	44	Disc Console Group
22	Pilot Ignition Electrode	45	Servomotor
23	Pilot Combustion Head		

ECO 70 OLC2

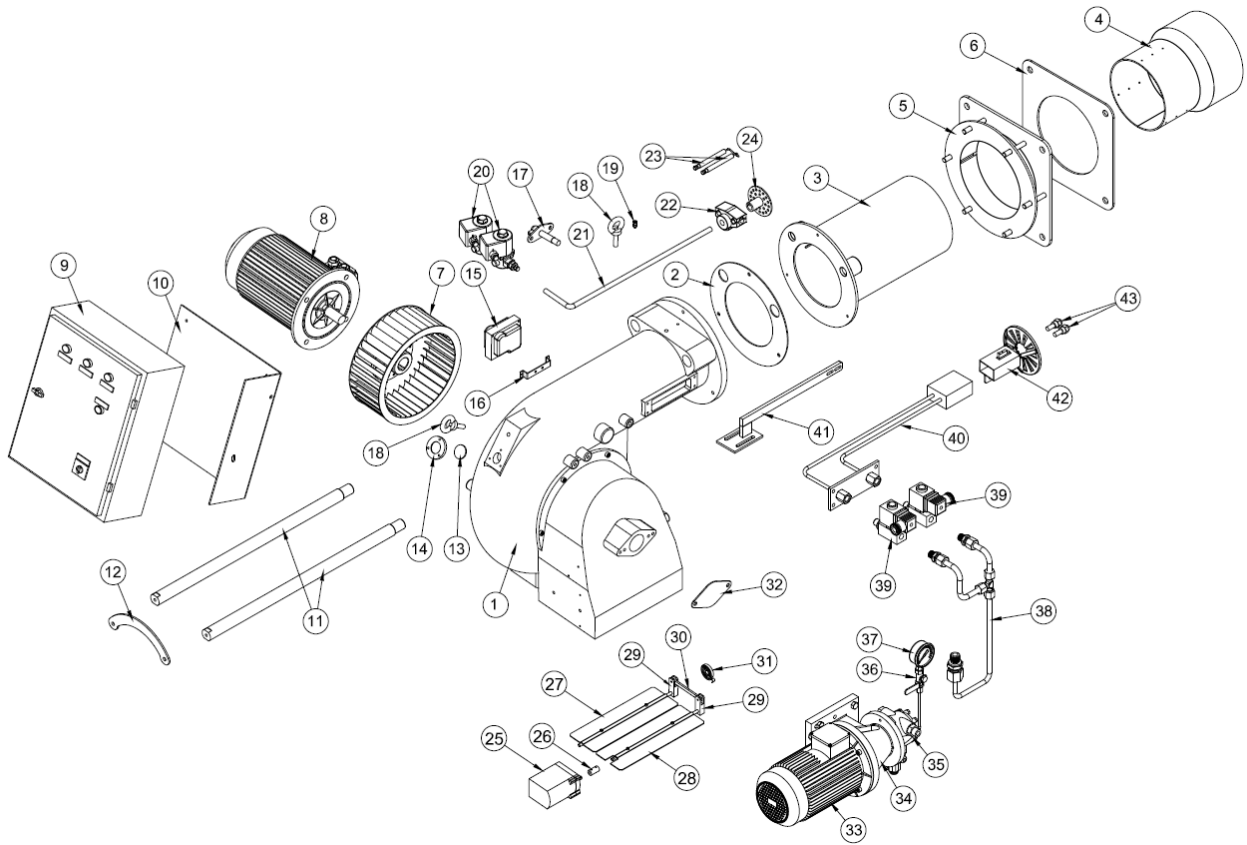

Assembly No	Part Name	Assembly No	Part Name
1	Body	23	Pilot Ignition Electrode
2	Klingerit Gasket	24	Pilot Combustion Head
3	Flame Tube	25	Servomotor
4	Air Adjustment Mechanism	26	Servomotor Coupling
5	Boiler Connection Flange	27	Air Damper
6	Gasket	28	Air Damper
7	Fan	29	Air Damper Motion Rod
8	Motor	30	Air Damper Motion Transfer Rod
9	Electrical Panel	31	Air Dumper Spring
10	Electrical Panel Mounting Plate	32	Pump Cover
11	Handling Shaft	33	Motor
12	Shaft Fixing Plate	34	Pump Motor Console
13	Observation Glass	35	Pump
14	Observation Frame	36	Ball Valve
15	Ignition Transformer	37	Manometer
16	Transformer Mounting Plate	38	Fuel Pipes
17	Photocell	39	Solenoid Valve
18	Eyebolt	40	Lance
19	Purger	41	Lance Centring Console
20	Gas Solenoid Valve	42	Combustion Head
21	Pilot Gas Pipe	43	Fuel Nozzle
22	Electrode Clamp		

ECO 70 OLC3

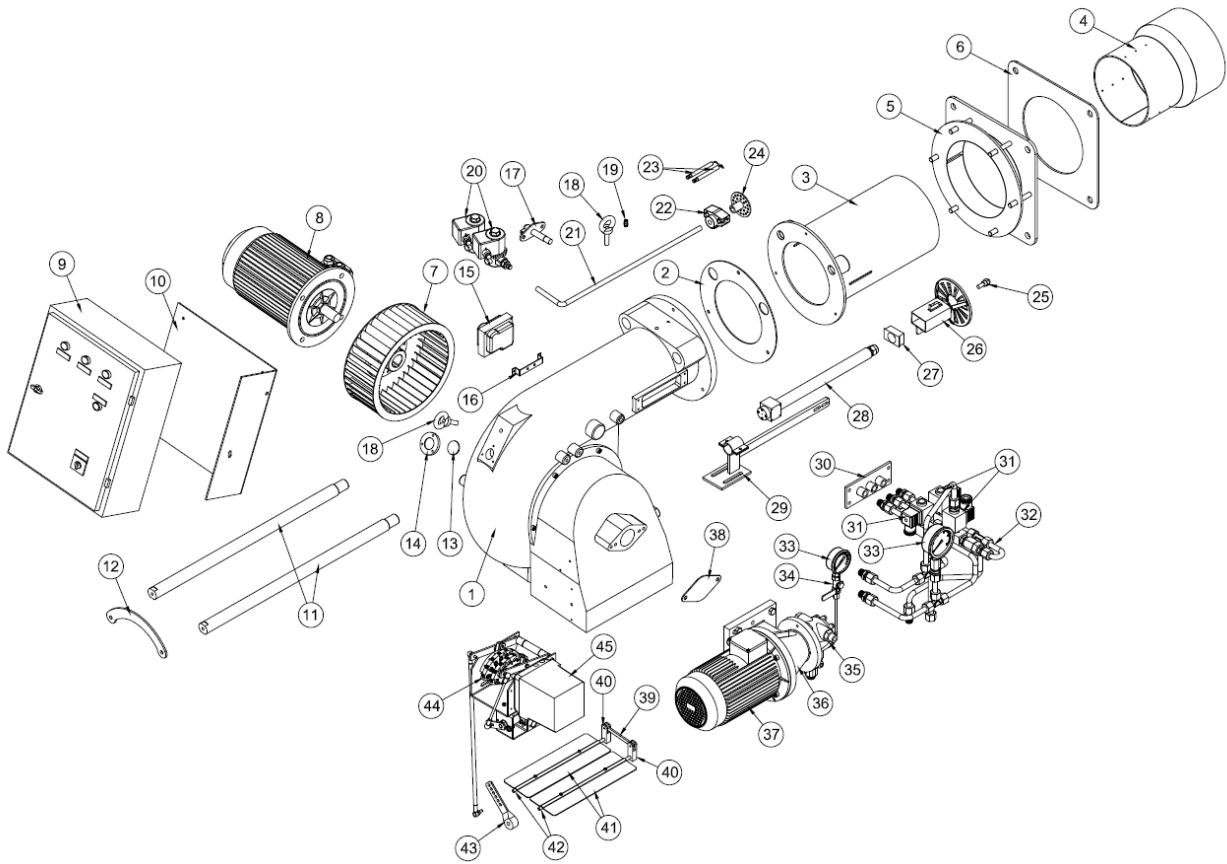

Assembly No	Part Name	Assembly No	Part Name
1	Body	24	Pilot Combustion Head
2	Klingerit Gasket	25	Fuel Nozzle
3	Flame Tube	26	Combustion Head
4	Air Adjustment Mechanism	27	Centring Wedge
5	Boiler Connection Flange	28	Lance
6	Gasket	29	Lance Centring Console
7	Fan	30	Solenoid Valve Connection Plate
8	Motor	31	Solenoid Valve
9	Electrical Panel	32	Fuel Pipes
10	Electrical Panel Mounting Plate	33	Manometer
11	Handling Shaft	34	Ball Valve
12	Shaft Fixing Plate	35	Pump
13	Observation Glass	36	Pump Motor Console
14	Observation Frame	37	Motor
15	Ignition Transformer	38	Pump Cover
16	Transformer Mounting Plate	39	Air Damper Motion Transfer Rod
17	Photocell	40	Air Damper Motion Rod
18	Eyebolt	41	Air Damper Plate
19	Purger	42	Air Damper Shaft
20	Gas Solenoid Valve	43	Air Damper Adjustment Rod
21	Pilot Gas Pipe	44	Disc Console Group
22	Electrode Clamp	45	Servomotor
23	Pilot Ignition Electrode		

ECO 75 OLC3

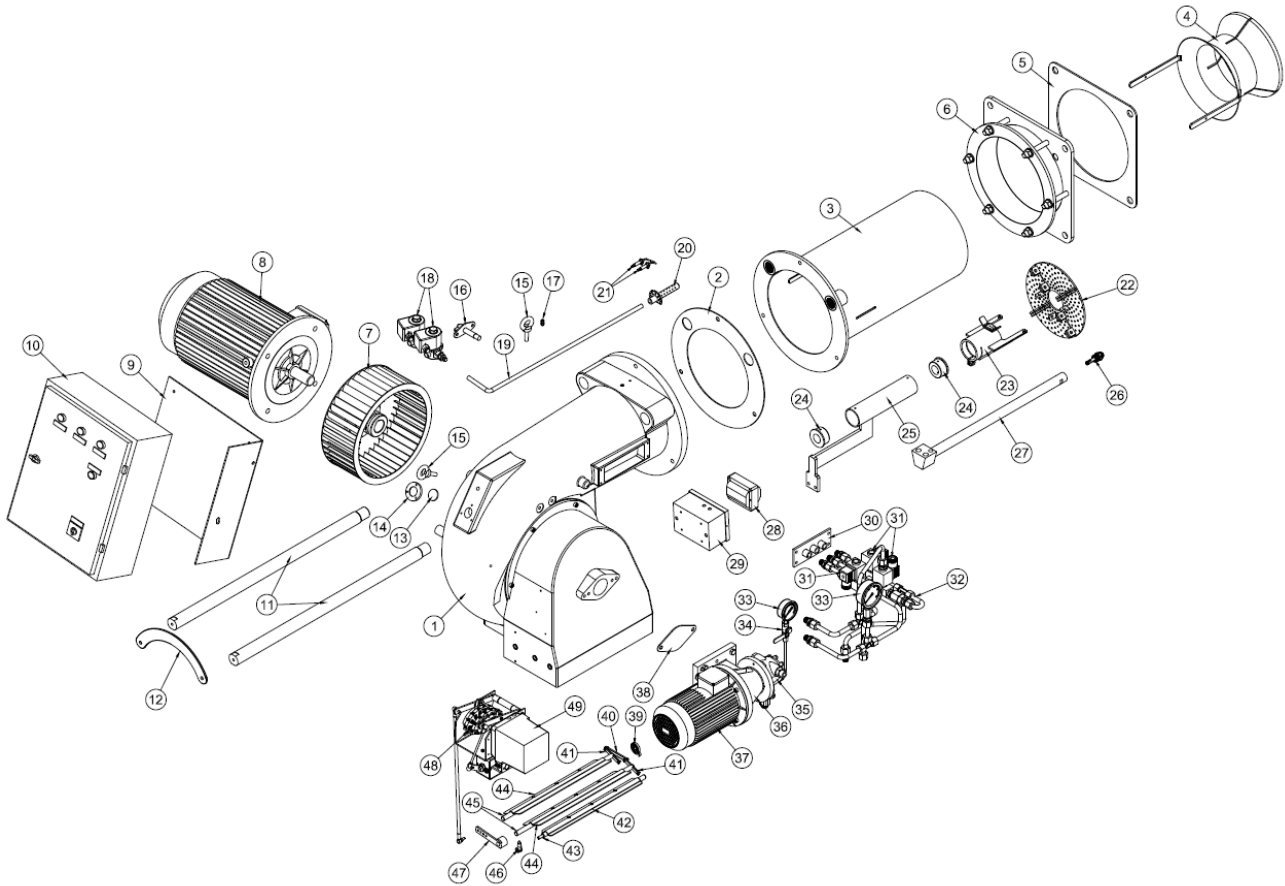

Assembly No	Part Name	Assembly No	Part Name
1	Body	26	Fuel Nozzle
2	Klingerit Gasket	27	Lance
3	Flame Tube	28	Ignition Transformer
4	Air Adjustment Mechanism	29	Transformer Box
5	Gasket	30	Solenoid Valve Connection Plate
6	Boiler Connection Flange	31	Solenoid Valve
7	Fan	32	Fuel Pipes
8	Motor	33	Manometer
9	Electrical Panel Mounting Plate	34	Ball Valve
10	Electrical Panel	35	Pump
11	Handling Shaft	36	Pump Motor Console
12	Shaft Fixing Plate	37	Motor
13	Observation Glass	38	Pump Cover
14	Observation Frame	39	Air Dumper Spring
15	Eyebolt	40	Air Damper Motion Transfer Rod
16	Photocell	41	Air Damper Motion Rod
17	Purger	42	Air Damper Plate
18	Gas Solenoid Valve	43	Air Damper Shaft
19	Pilot Gas Pipe	44	Air Damper Plate
20	Pilot Combustion Head	45	Air Damper Shaft
21	Pilot Ignition Electrode	46	Damper Gauge
22	Combustion Head	47	Air Damper Adjustment Rod
23	Combustion Head Connection Part	48	Disc Console Group
24	Centring Cage	49	Servomotor
25	Lance Centring Console		

4. FLUE GAS AND HEATING WATER SCHEMA

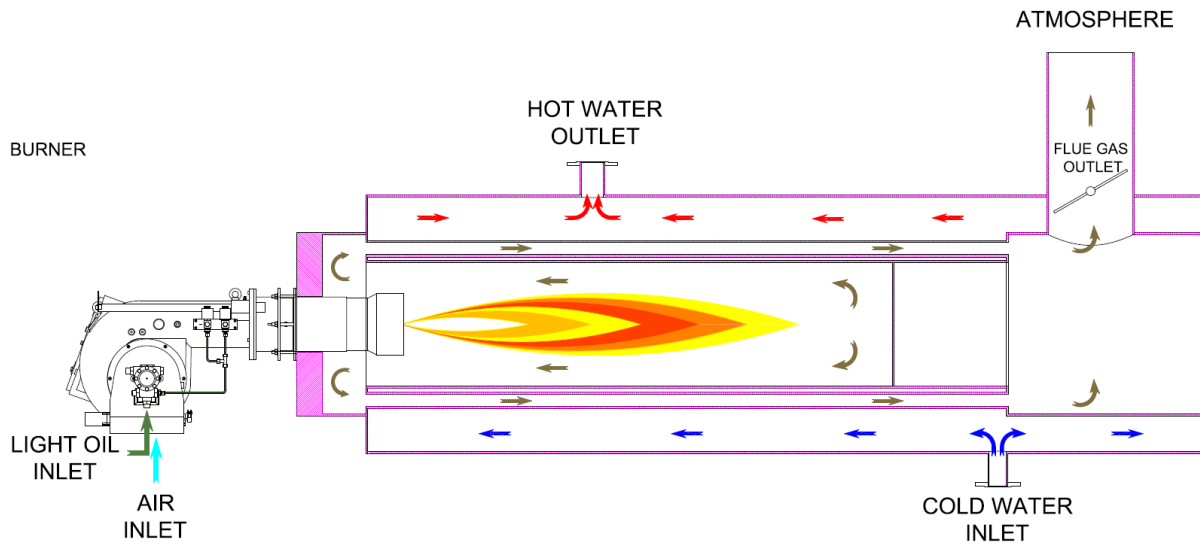

5. TECHNICAL DATA

5.1. Capacity Table

LIGHT OIL BURNERS CAPACITY TABLE									
BURNER TYPE	CAPACITY		CAPACITY		LIGHT OIL CONSUMPTION		FAN MOTOR POWER	OIL PUMP POWER	MAIN SUPPLY
	Min. kcal/h	Max. kcal/h	Min. kW	Max. kW	Min. kg/h	Max. kg/h	kW	kW	VAC
TWO STAGE LIGHT OIL BURNERS									
ECO 50 O (L) C 2	357.000	1.428.000	415	1.660	35	140	2,20	-	3N 380
ECO 55 O (L) C 2	408.000	1.836.000	474	2.135	40	180	3,00	-	3N 380
ECO 55 O (L) C 2a	408.000	2.244.000	474	2.609	40	220	3,00	-	3N 380
ECO 60 O (L) C 2	632.400	2.723.400	735	3.167	62	267	4,00	0,75	3N 380
ECO 65 O (L) C 2	775.200	3.182.400	901	3.700	76	312	5,50	0,75	3N 380
ECO 70 O (L) C 2	969.000	3.702.600	1.127	4.305	95	363	7,50	0,75	3N 380
MODULATING LIGHT OIL BURNERS									
ECO 50 O (L) C 3	357.000	1.428.000	415	1.660	35	140	2,20	-	3N 380
ECO 55 O (L) C 3	408.000	1.836.000	474	2.135	40	180	3,00	-	3N 380
ECO 55 O (L) C 3a	408.000	2.244.000	474	2.609	40	220	3,00	-	3N 380
ECO 60 O (L) C 3	632.400	2.723.400	735	3.167	62	267	4,00	1,10	3N 380
ECO 65 O (L) C 3	775.200	3.182.400	901	3.700	76	312	5,50	1,50	3N 380
ECO 70 O (L) C 3	969.000	3.702.600	1.127	4.305	95	363	7,50	1,50	3N 380
ECO 75 O (L) C 3	1.060.800	5.100.000	1.233	5.930	104	500	11,00	1,50	3N 380

H_u Light Oil (L) = 10200 Kcal/kg

5.2. Back Pressure-Capacity Diagrams

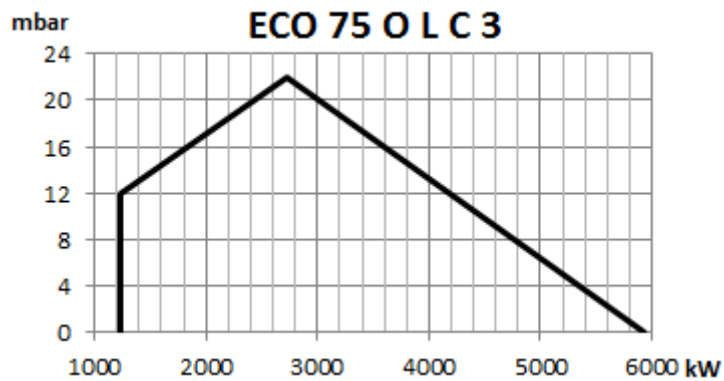
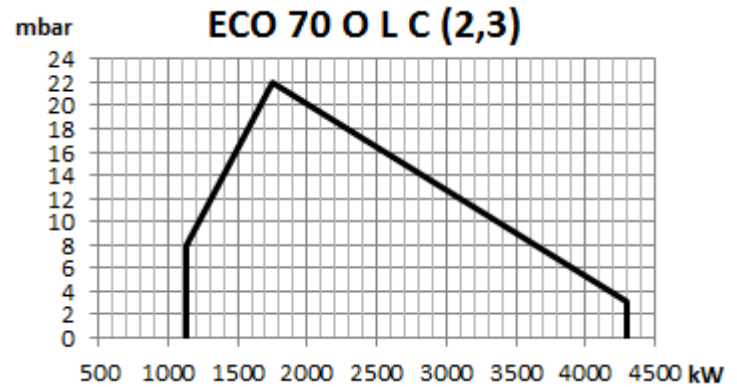
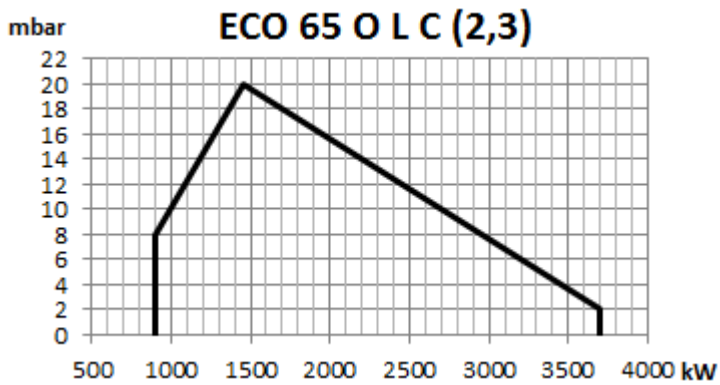
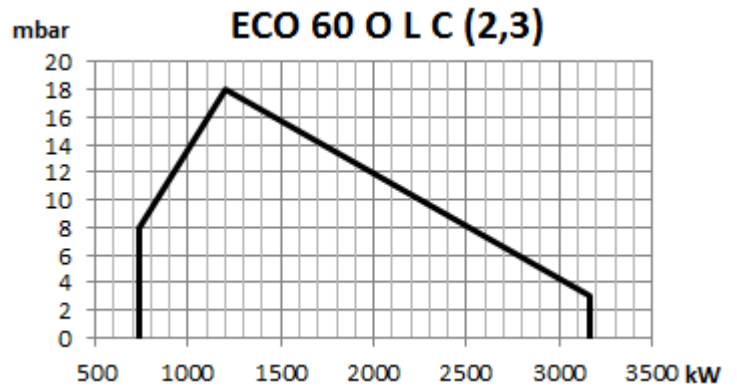
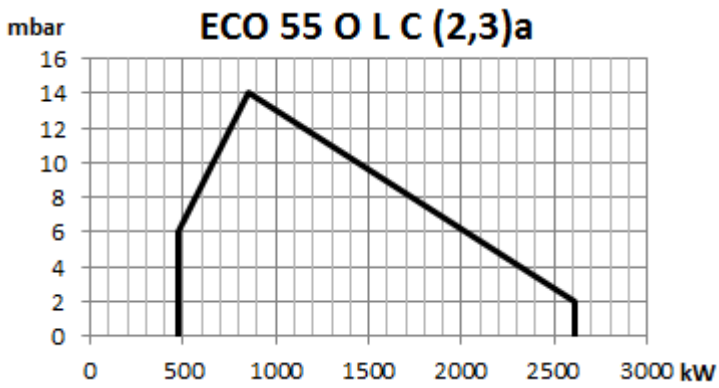
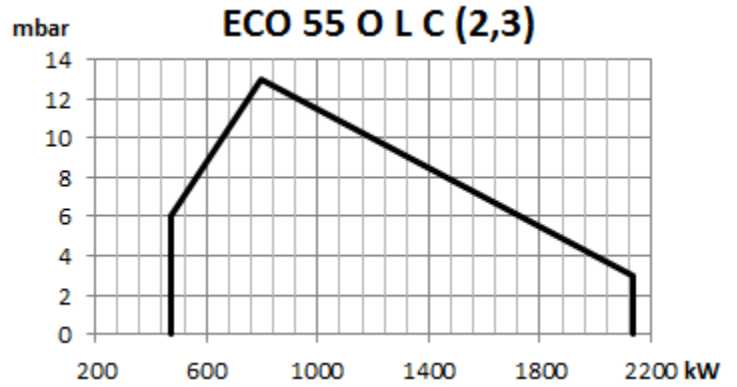
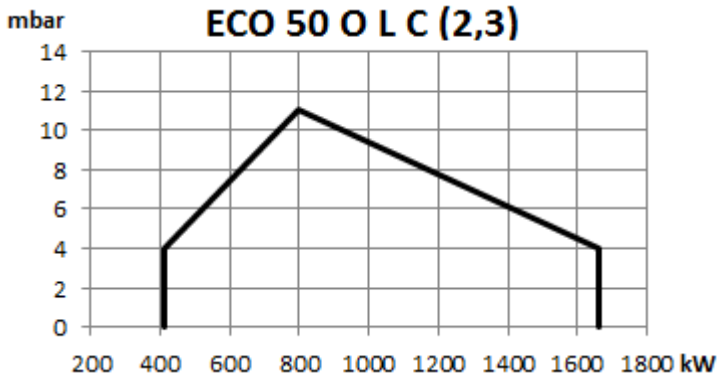

5.3. Burner Dimensions

ECO 50 ECO 55

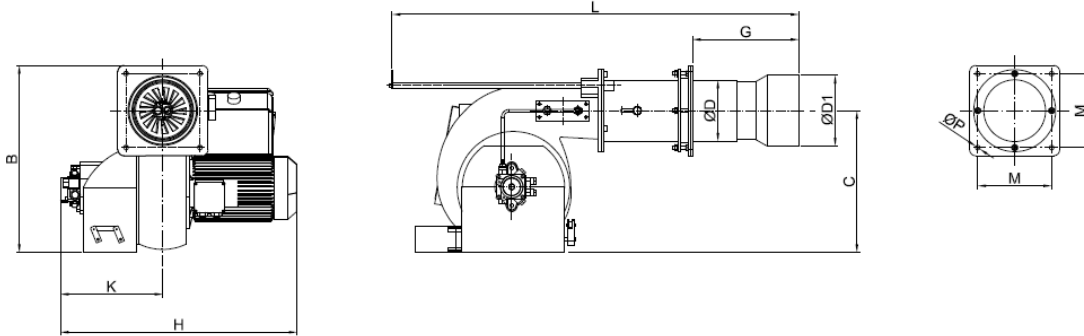

ECO 65 ECO 70

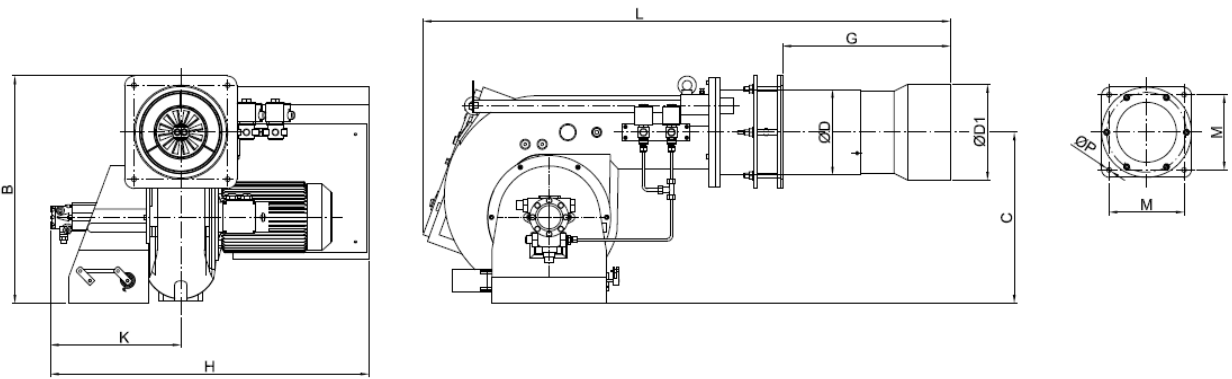

ECO 60 ECO 75

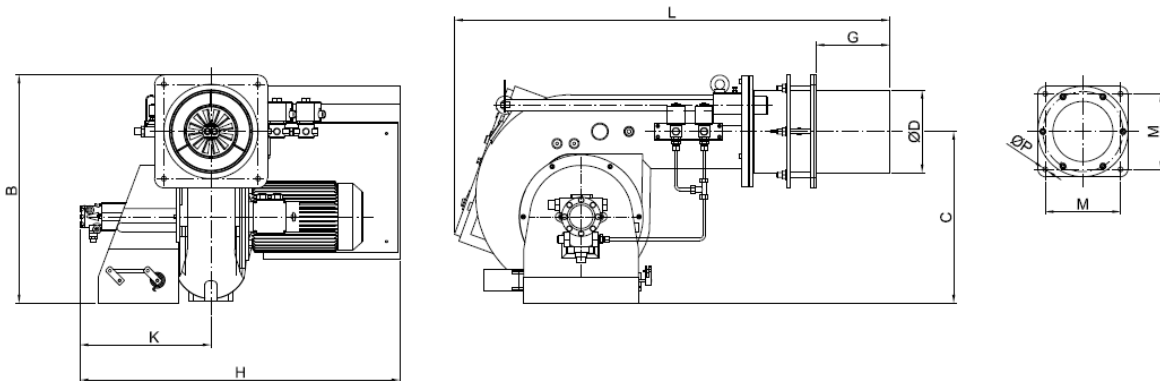

	L	Gmin	Gmax	H	K	B	C	ØP	M	ØD	ØD1
ECO 50 O (L)	1370	280	440	780	360	590	422	18	275	218	236
ECO 55 O (L)	1370	280	440	780	360	590	422	18	275	218	236
ECO 60 O (L)	1300	-	140	950	400	670	510	18	275	240	-
ECO 65 O (L)	1580	200	535	950	400	670	510	18	275	250	280
ECO 70 O (L)	1580	200	535	950	400	670	510	18	275	250	280
ECO 75 O (L)	1500	200	285	870	360	730	525	22	335	300	-

5.4. Flame Length and Diameter

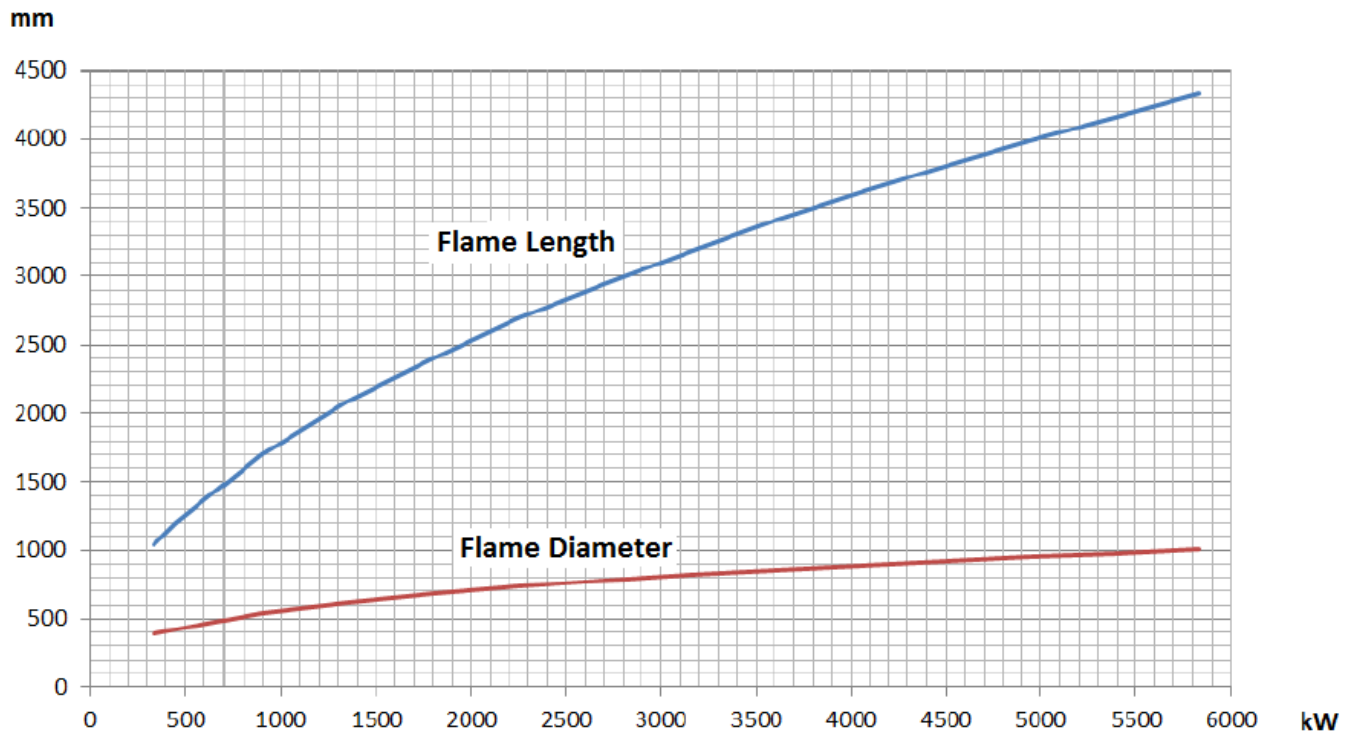

5.5. Noise Level

Product operates within the range of 75 decibels max. and 85 decibels.

6. BURNER HANDLING INFORMATION



- Lift the product by holding the handles as seen in the picture.
- Prevent strong impacts on top of the product and vibration while handling the product.
- Do not leave the product in wet environment.



Dimensions of the box used for handling

Burner	L x W x H (cm)	Weight(kg)
ECO 50 OLC2	135 X 82 X 70	110
ECO 50 OLC3	135 X 82 X 70	110
ECO 55 OLC2	135 X 82 X 70	110
ECO 55 OLC2a	135 X 82 X 70	110
ECO 55 OLC3	136 X 90 X 75	133
ECO 55 OLC3a	136 X 90 X 75	133
ECO 60 OLC2	136 X 115 X 85	228
ECO 60 OLC3	136 X 115 X 85	228
ECO 65 OLC2	170 X 115 X 85	244
ECO 65 OLC3	170 X 115 X 85	244
ECO 70 OLC2	170 X 115 X 85	244
ECO 70 OLC3	170 X 115 X 85	244
ECO 75 OLC3	165 X 120 X 90	270

7. INSTALLATION

7.1. Burner Installation Picture

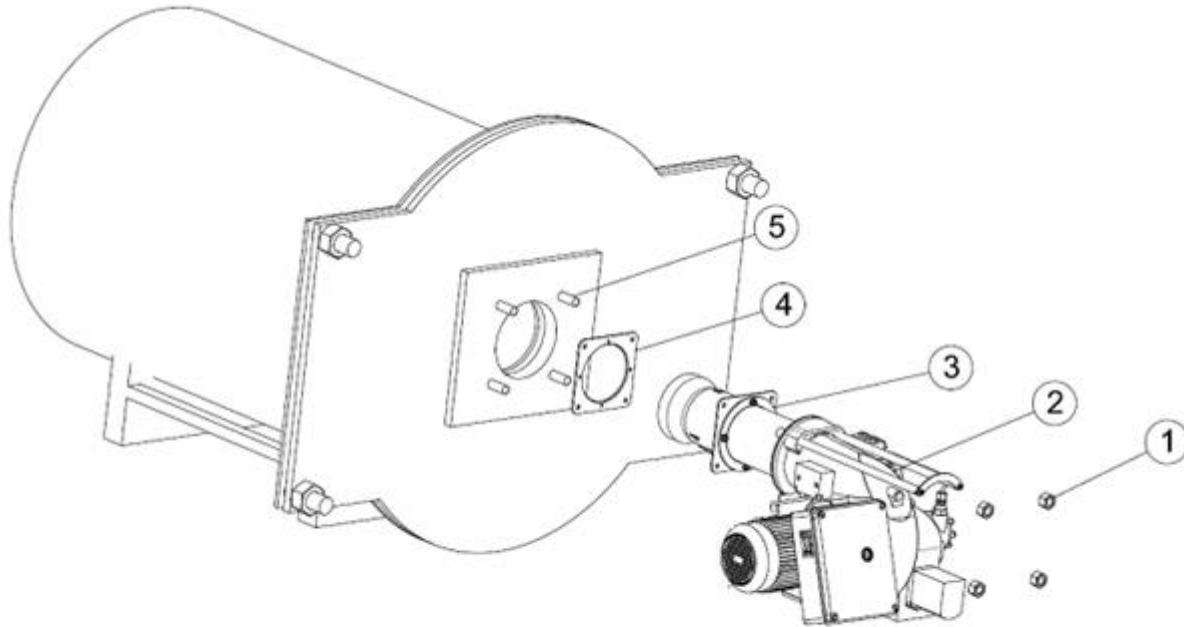

- 1- Drift Bolts
- 2- Burner
- 3- Boiler Connection Flange
- 4- Gasket
- 5- Boiler Studs

- In the installation of the burner, use the installation materials supplied with the burner.
- Secure the burner connection flange onto the burner cover by 4 bolts. Gasket must be connected such that it will remain between connecting flange and boiler cap.

After completing the installation of the burner on the boiler:

- Connect the oil feed pipes.
- Connect the burner panel to the mains by a cable suitable for the rated power.



Clean the inside of fuel line thoroughly before installing the burner to the fuel line. Any damage that may occur due to solid objects and metal particles from the fuel line shall not be covered by our company.

7.2. In reverse flame front mirror boilers

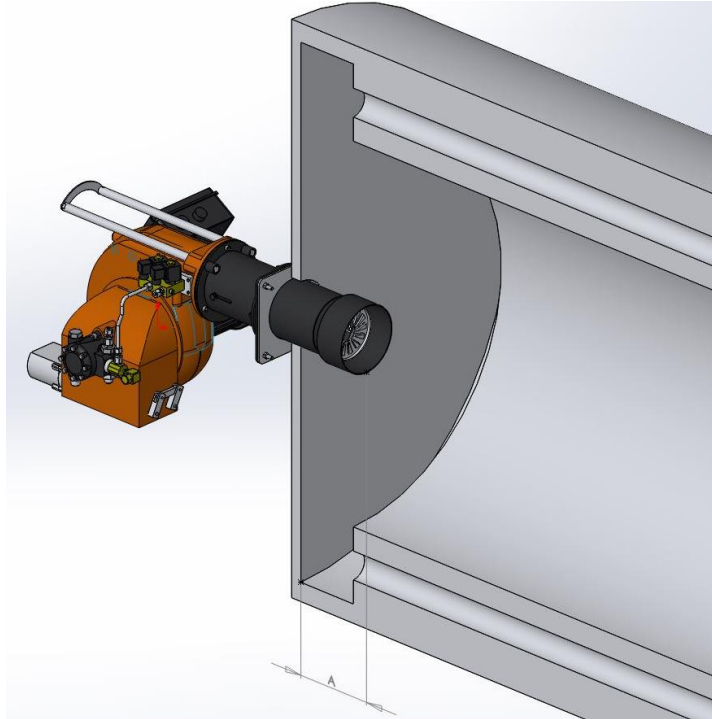

While installing the burner in reverse flame front mirror boilers, flame tube tip must be adjusted such that it gets inside by 50 mm-100 mm from flue pipes ($50\text{mm} \leq A \leq 100\text{mm}$). Otherwise flue gas temperature will rise and fuel consumption will increase.

7.3. In cylindrical (straight flame) boilers

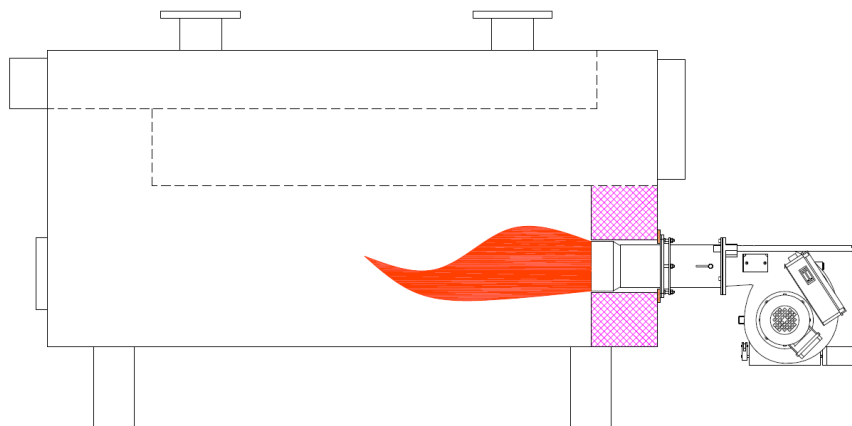

8. COMMISSIONING

8.1. Before Commissioning



Electrical Connection

Perform electrical connections according to the diagram provided with the burner. Follow general security rules during installation of electric wiring and making connections. Connect the earthing terminal in electric panel to the earthing installation.

8.2. General Controls



Make sure to perform the following controls before commissioning the burner.

- Installation of the burner to the boiler is checked.
- Check the fuel line (are the pipe diameters and the pipe installation correct?).
- Check energy input cables and voltages.
- Check the boiler safety thermostats and, if it is a two-stage burner, then make sure that there are two thermostats.
- Check the fuel nozzles according to the boiler capacity.
- Prior to operating the burner, control the boiler water level.
- Make sure water circulation system is turned on, and steam boiler and water feed pumps and boiler inlet - outlets are open.

Commissioning order

- After performing the above mentioned controls, open the fuel tank valve.
- Open the valve upstream of the fuel filter.
- Check direction of motor rotation.
- Open the pump's vent plug and place the manometer (0-40 bar).
- Turn on the burner switch (turn to position 1).
- When the burner starts up, the motor is activated and turns the pump at the same time.
- The pump filter should be cleaned frequently (every 30 minutes) during the first commissioning, and please ensure that the fuel reaches the pump without interruption.
- It actuates pre-purge and discharges the residual gases remaining in the boiler from the funnel.
- After the pre-purge, fuel is delivered from the nozzle. The fuel meets the flame from the ignition electrodes and the combustion starts.
- After combustion of the burner, the pump pressure is adjusted (two stage 14 bar, modulating 25 bar).
- If the burner has two stages, the switch is brought to position "2", and the capacity of the burner is increased through servomotor. Ideal combustion is obtained by increasing the amount of air by the fuel given according to analyses value.
- The boiler thermostat is adjusted as desired (70-90°C for central heating boilers).
- For the safety of the system, check the boiler thermostats and observe the deactivation of the burner.

8.3. Combustion Adjustment

➤ Fuel nozzle

Use proper wrench in installation and dismantle of the fuel nozzle.

Use diesel oil to clean the fuel nozzle. Do not use thinner and its derivatives.

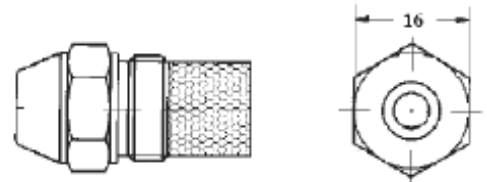

➤ Photocell

Check the photocell weekly. Clean the dust or fume stains on the glass of photocell by a dry cloth.



8.4. Fuel Pumps

E Type

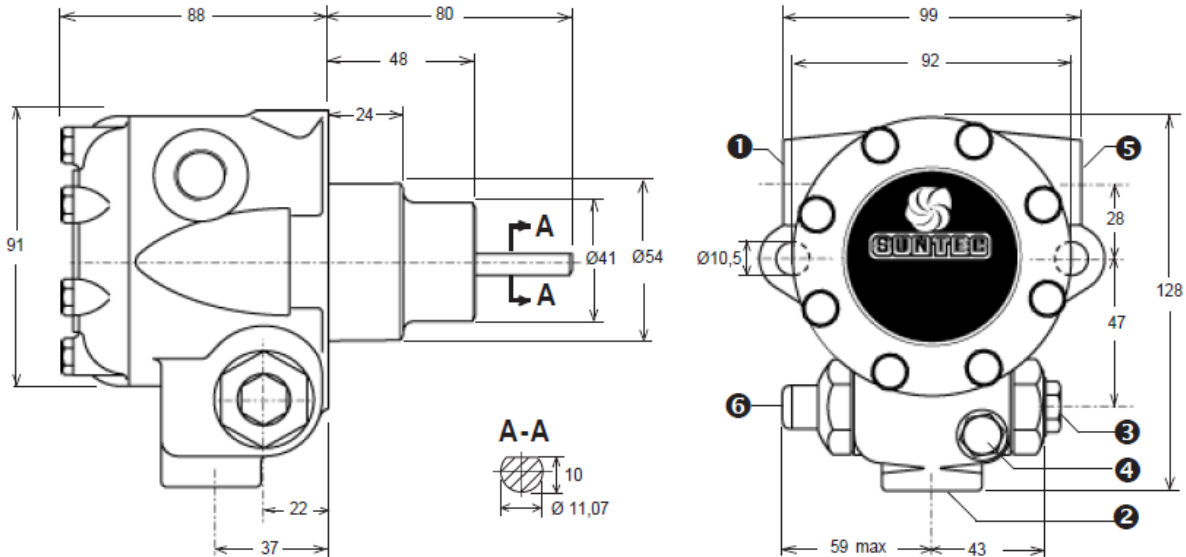

- 1- Suction or vacuum manometer connection
- 2- Return and internal bypass
- 3- Nozzle outlet
- 4- Manometer connection
- 5- Suction or vacuum manometer connection
- 6- Pressure adjustment

TA Type

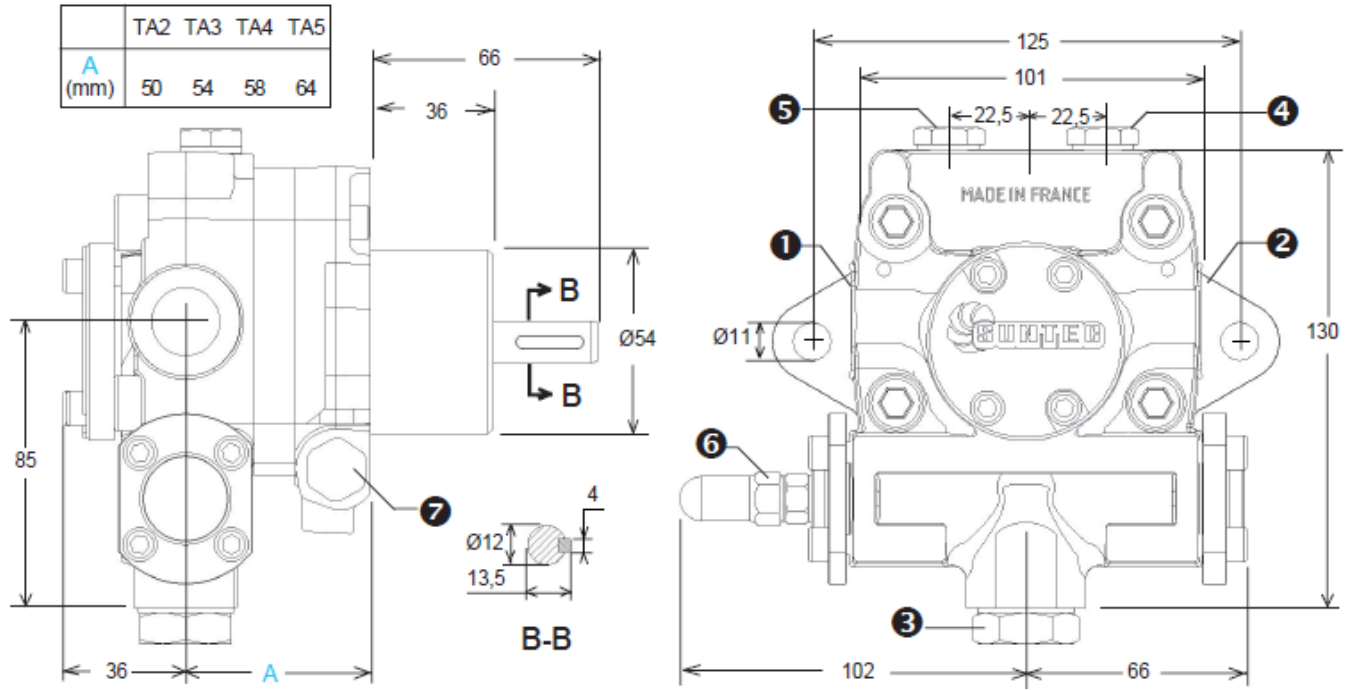

1. Suction
2. Nozzle outlet
3. Return
4. Manometer inlet
5. Vacuum or inlet manometer and internal return inlet
6. Pressure adjustment
7. Pre heater location

➤ **Two Stages Light Oil Burner Fuel Circuit**

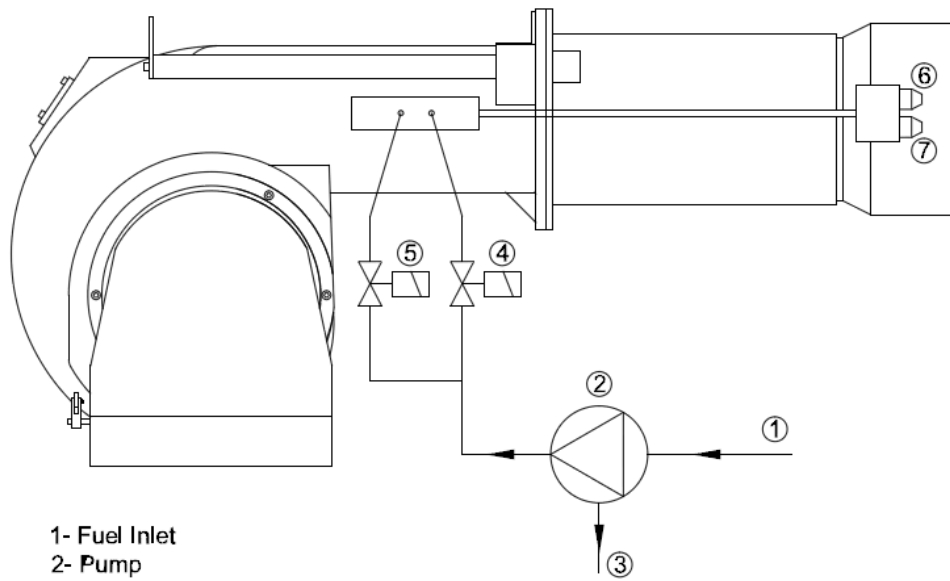

- 1- Fuel Inlet
- 2- Pump
- 3- Fuel Return
- 4- 1. Stage Solenoid Valve
- 5- 2. Stage Solenoid Valve
- 6- 1. Stage Fuel Nozzle
- 7- 2. Stage Fuel Nozzle

➤ **Modulating Light Oil Burner Fuel Circuit**

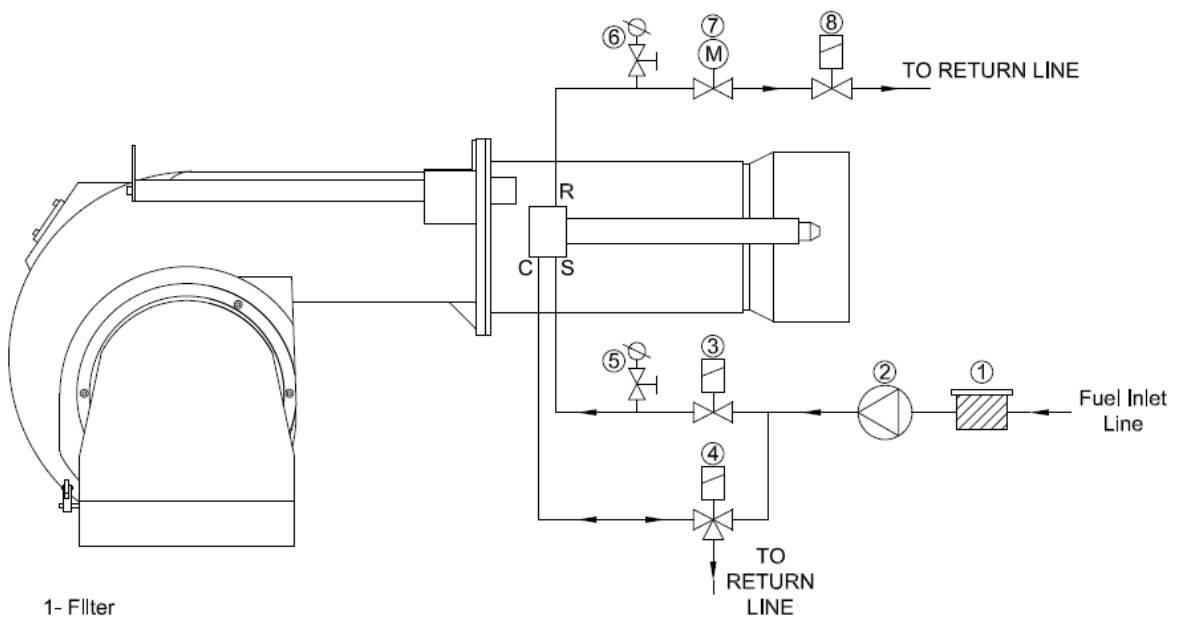

- 1- Filter
- 2- Pump
- 3- Safety Inlet Valve
- 4- Hydraulic Control Valve
- 5- Manometer
- 6- Manometer
- 7- Oil Set Valve
- 8- Safety Outlet Valve



CAUTION!

- **End of the line to the main tank must be open to the atmosphere and line pressure must be zero, otherwise no healthy modulating operation can be ensured since the pressure, which is to form in return, will also affect nozzle pressure. Fuel may drop from nozzle end during stops.**

- **For good pulverization, periodically check durability of the o-ring. In the event of earing of the o-ring, fuel to the nozzle can by-pass and go directly to the return and reduces the working performance of the nozzle.**

- **Maximum operating pressure of the nozzle is 30 bars. This value should not be exceeded during working. Even if these out of control value are exceeded, nozzle must be taken to emergency maintenance and all O-rings must be replaced.**

- **Do not use solvent based materials (thinner and derivatives) during cleaning of the fuel nozzle; clean with gas oil or diesel oil. Fuel nozzle inner kit is very sensitive and even invisible deformations can reduce working performance; dismantling-installing work must be performed only by trained personnel.**

- **Spring has lost its function if dropping from fuel nozzle or fuel exit at large scale is observed when the nozzle performs circulation. It must be checked and replaced if necessary.**

- **During fuel supply, the pressure at the burner fuel pump must be max. 0,40 +0,05 bar for light oil . When the burner is not operating or operating at the maximum fuel flow required, fuel supply pressure value should not changed in the burner pump.**

8.5. Servomotor Adjustment

➤ SQN70

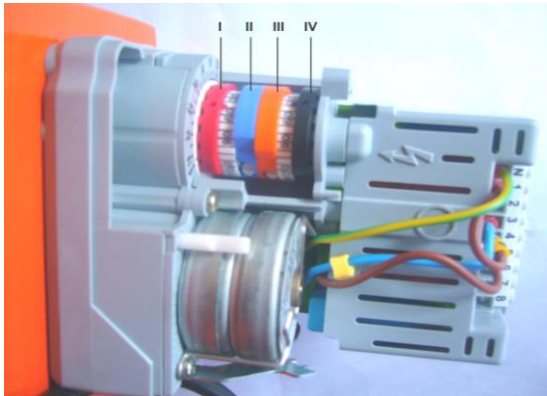

At Two-stage Burners;

- I. Red Cam: Adjusts 2nd level max. air.
- II. Blue Cam: Resets the clamp.
- III. Orange Cam: Adjusts 1st level min. air.
- IV. Black Cam: Adjusts 2nd level valve opening degree.

At Modulating Burners;

- I. Red Cam: Performance max. air adjustment.
- II. Blue Cam: Resets the clamp.
- III. Orange Cam: Performs min. air adjustment.
- IV. Black Cam: Not used.

➤ SQM10



- I. Cam: Opening
- II. Cam: Resets the clamp
- III. Cam: Commissioning air
- IV. V.VI. and VII. Cam not used

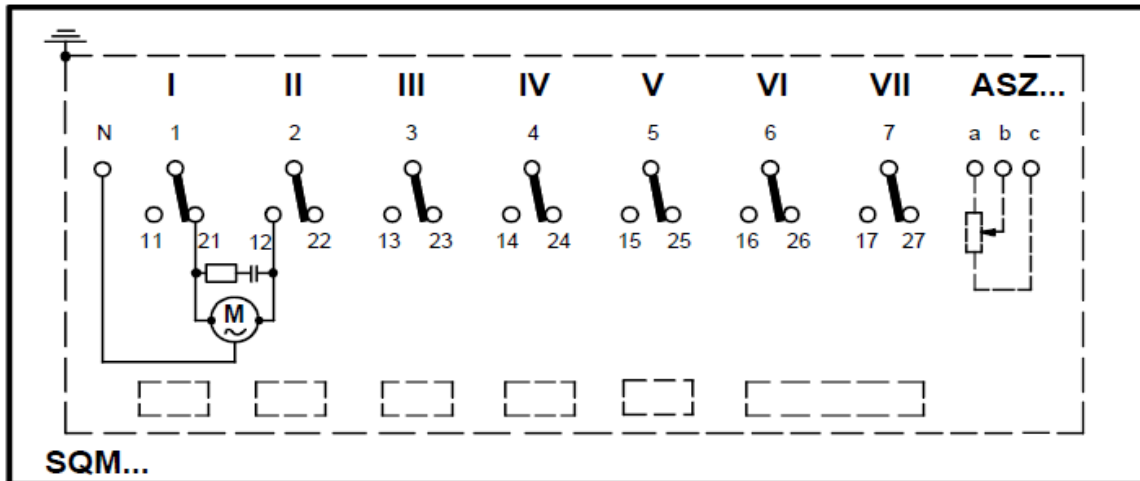

7812a01/1097

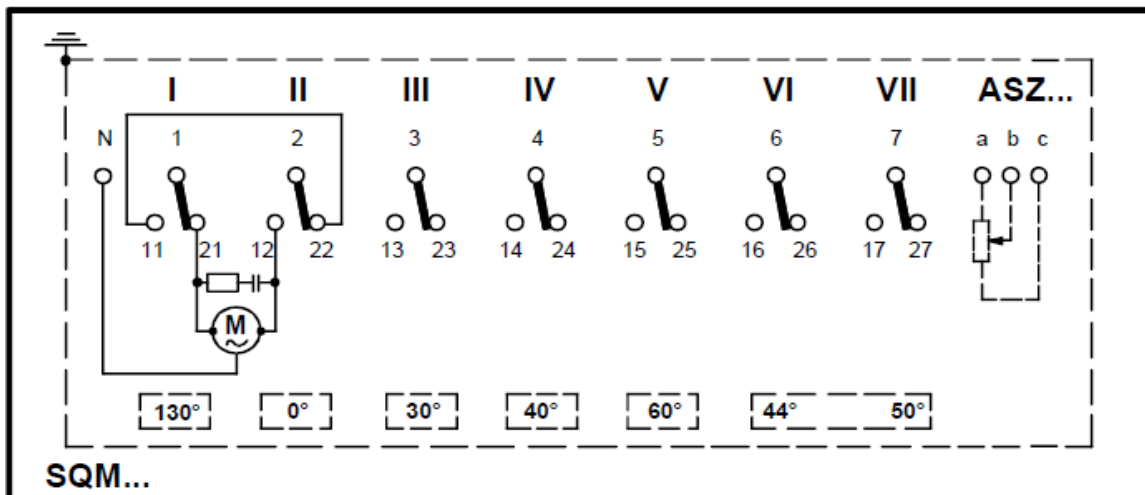

7812a02/1097



Do not open servomotor. Do not interfere with. It may damage servomotor or change burner settings.

➤ **MODULATING MECHANISM ADJUSTMENT**

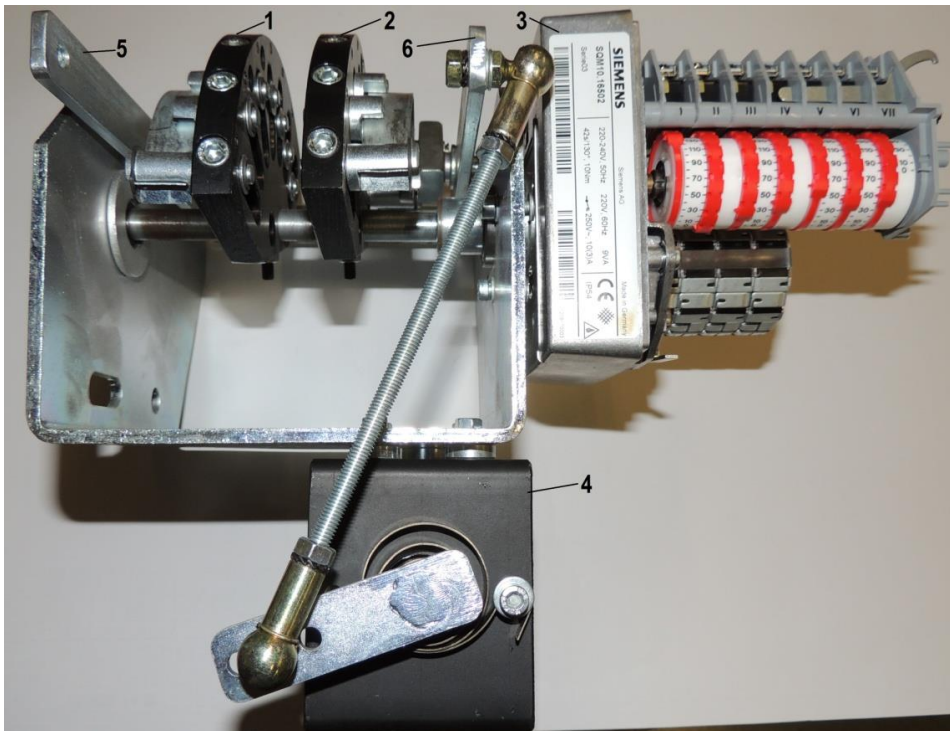

- 1- Air adjustment disk
- 2- Fuel adjustment disk
- 3- Servomotor
- 4- Fuel regulator
- 5- Air control lever
- 6- Fuel control lever

ADJUSTMENT:

1- Start positions prior to disc mechanism adjustment operation must be as follows:

- Servomotor: 0°
- Fuel adjustment disc at start position
- Air adjustment disc at start position
- Fuel regulator at position 10
- Air klappes at fully closed position: 0°

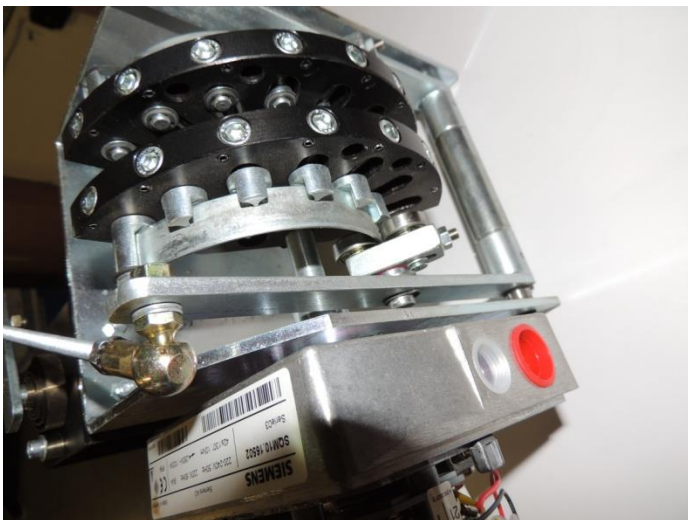

Start position for discs



Start position for fuel regulator

2 – If disc mechanism start positions are correct, start the burner and ensure that it activates in basic load. Detect min capacity activation fuel amount of the burner by checking min. return pressure. If the activation fuel amount is insufficient, set fuel regulator start adjustment to 9 or 8 value by changing spring adjustment from adjusting bolt on fuel disc number 2. When you start the burner again after this operation, you will see that your fuel return pressure has increased and hence activation fuel amount has risen.

3 – Slowly increase the capacity following burner basic load adjustment provided that modulating control device is in manual position. By setting 7 or 8 points during capacity increase, at these points:

- Measure emission values
- Record fuel return pressure
- Observe air klappe position
- Check fuel regulator scale value moves from 10 to 0.

4 - If you haven't been able to reach the max capacity required by the boiler in 90° position of the air klappe and 0° position of the fuel regulator once you have completed the maximum adjustment, follow the below fuel regulator adjustment procedure:

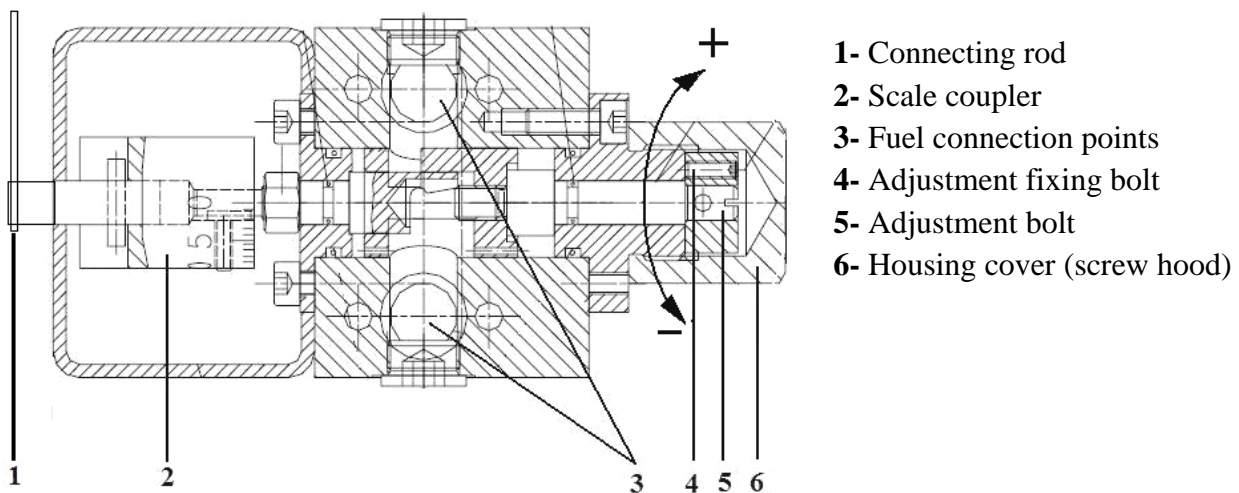

- 1- Connecting rod
- 2- Scale coupler
- 3- Fuel connection points
- 4- Adjustment fixing bolt
- 5- Adjustment bolt
- 6- Housing cover (screw hood)

Fuel Regulator Adjustment

- 1- Remove the housing cover number 6
- 2- Loosen the fixing bolt number 4
- 3- When you rotate the shaft number 5 (when looked from the shaft end) clockwise, the pressure value you observe from return manometer will increase, and burner consumption will also increase since nozzle pressure increases.
- 4- When you rotate the shaft number 5 (when looked from the shaft end) anti-clockwise, the pressure value you observe from return manometer will decrease, and burner consumption will also decrease since nozzle pressure decreases.
- 5- When the adjustment is completed, make sure that the adjustment you have made is permanent by tightening the fixing bolt number 4.
- 6- Place the housing cover number 6.

5 - Set the burner to the correct capacity required by the boiler by considering the below nozzle pressure and consumption values.

Diagram valid for fuel nozzles having 45° spraying angle

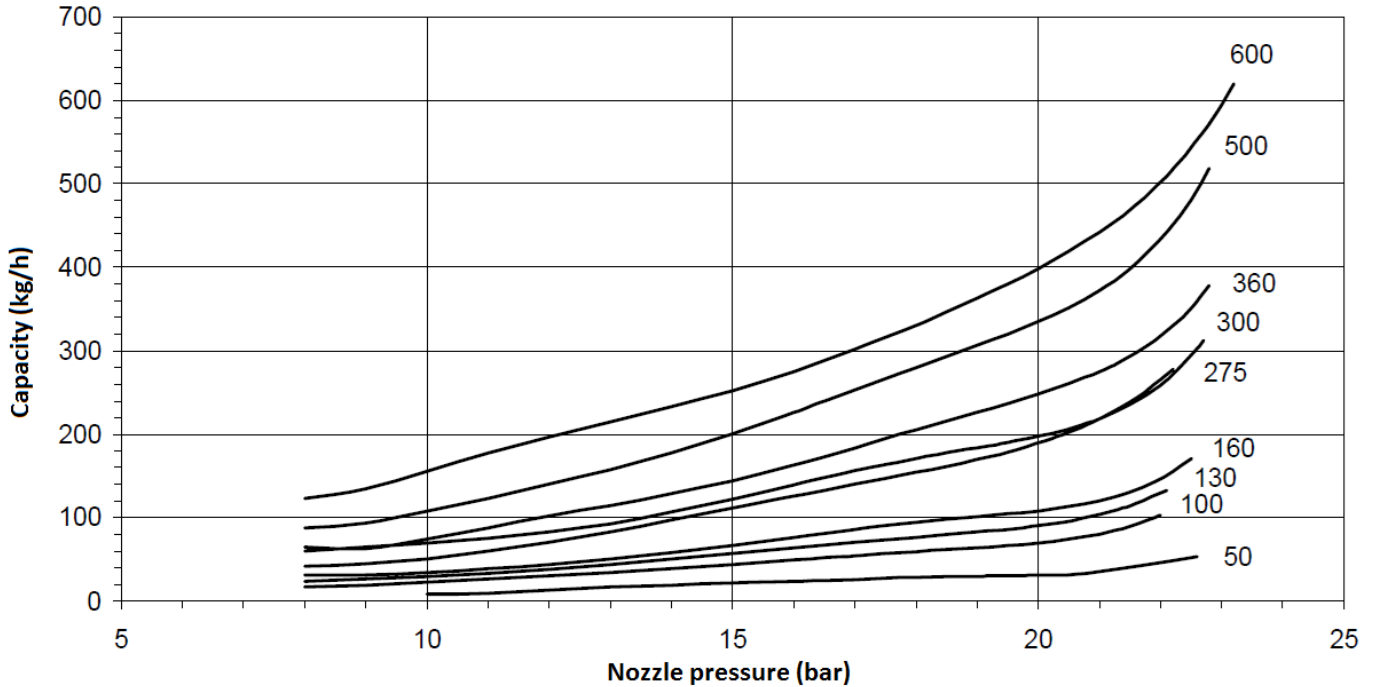
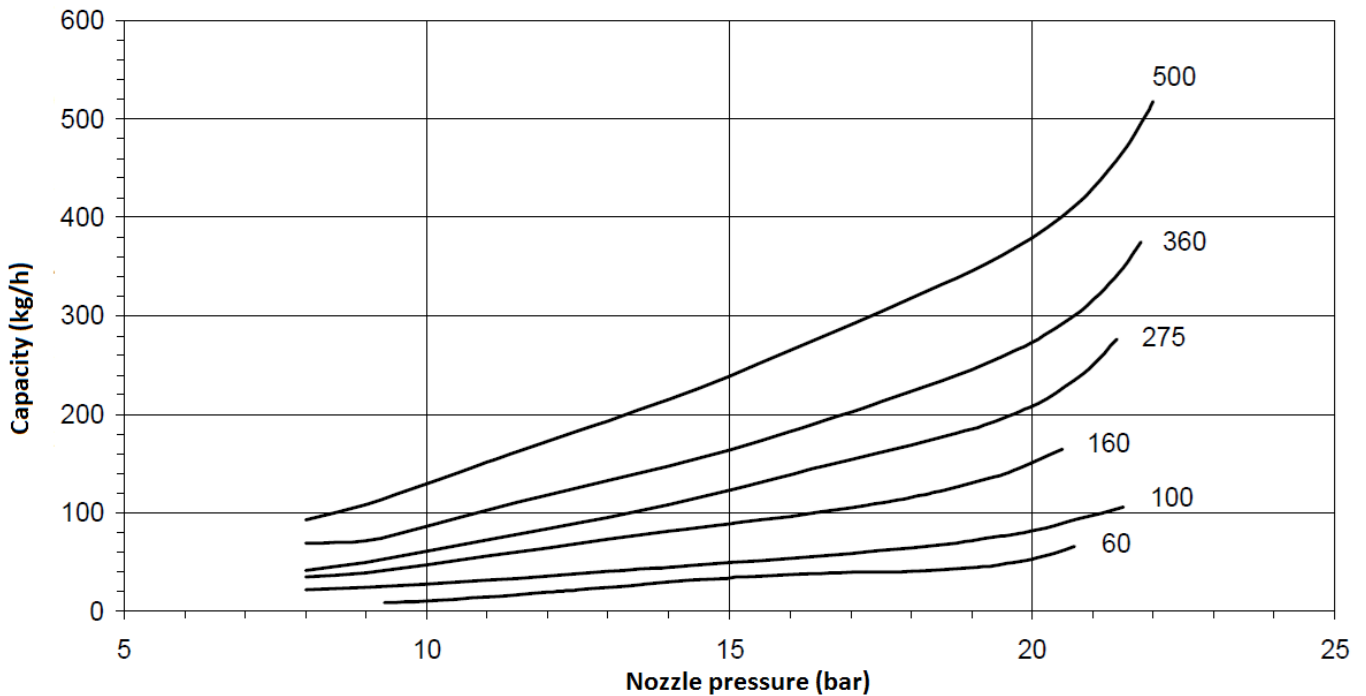

Diagram valid for fuel nozzles having 60° spraying angle



6 – Once the burner modulating adjustment is completed, set modulating control device to automatic position, change set values and observe capacity changes. Air and fuel will increase and decrease simultaneously according to the adjustment you previously made.

8.6. Emission Measurement

In emission measurements, the following values are accepted as reference according to TS EN 267 standard.

- CO < 110 mg/ kWh
- %3 ≤ O₂ ≤ %5
- NO_x < 250 mg/ kWh
- Excess air ratio $1,2 \leq \lambda \leq 1,3$

i It is important for the boiler to be sealed in order to avoid incorrect measurements during emission measurements.

i Boiler temperature must be between 40 C° and 80 C° while making emission measurement in hot water boilers.

8.7. Program Relay

LAL 1.25

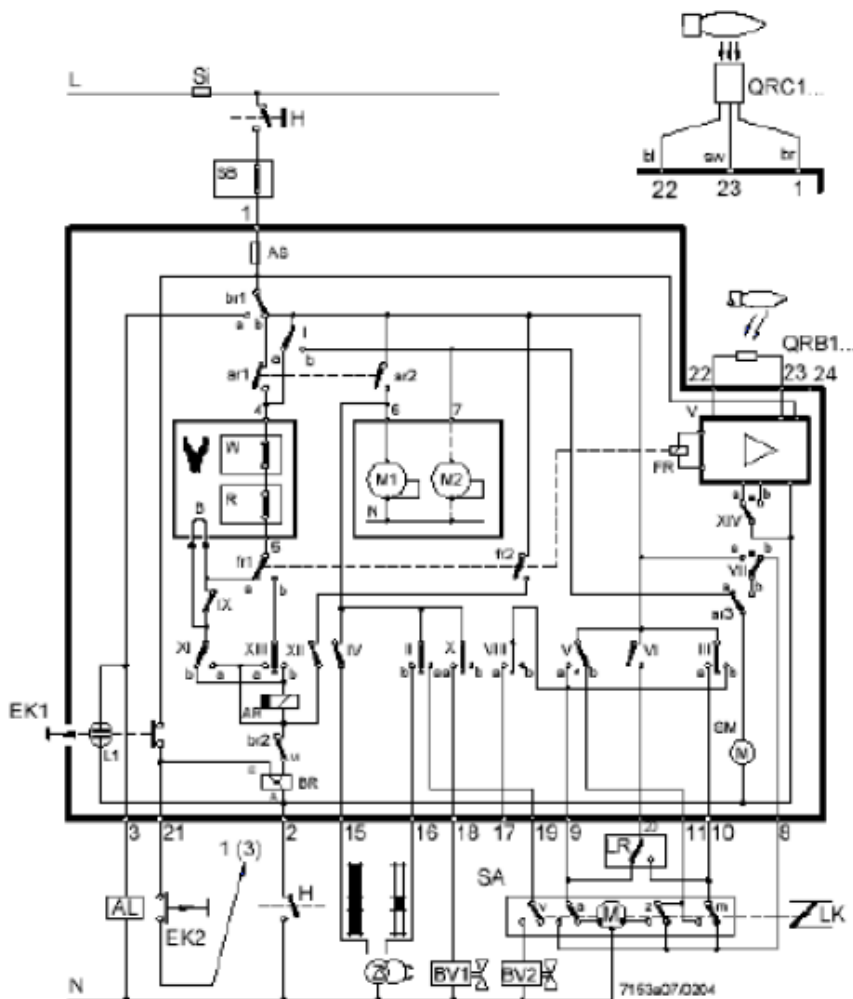



If the flame tube of the burner is longer than standard (standard flame tube length of the burner), please do not forget to support burner body during maintenance and installation/commissioning.

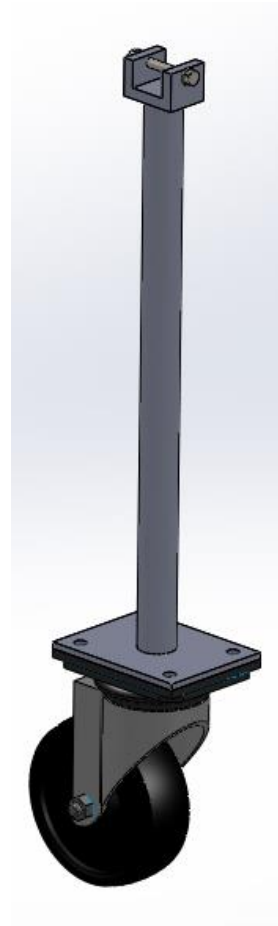
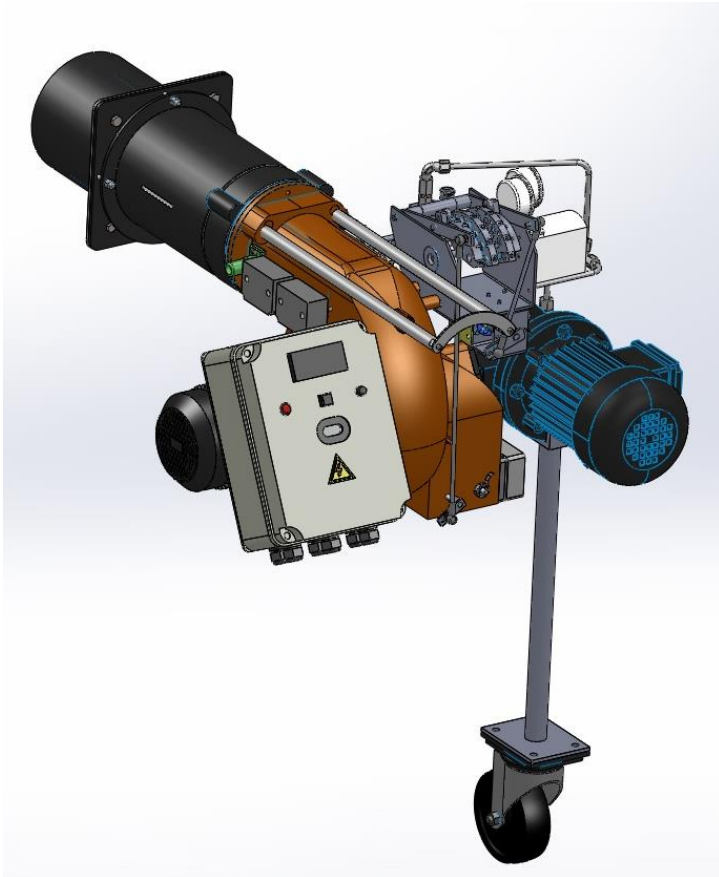

8.8. Light Oil Burner Fuel Ring Line

Tank is above the burner level.

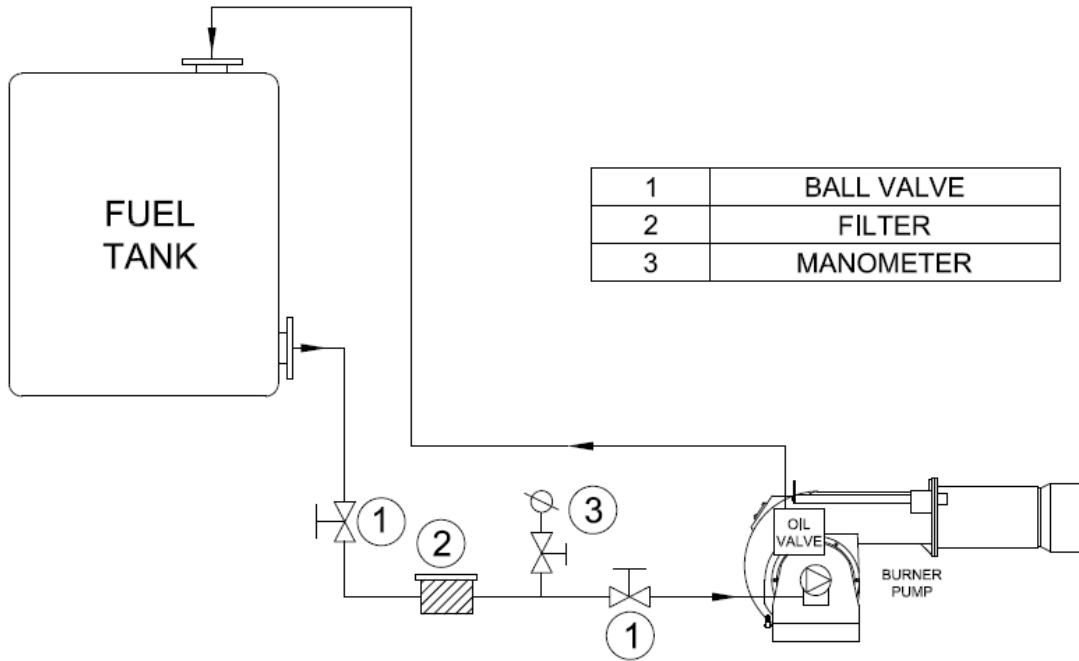

Tank is below the burner level.

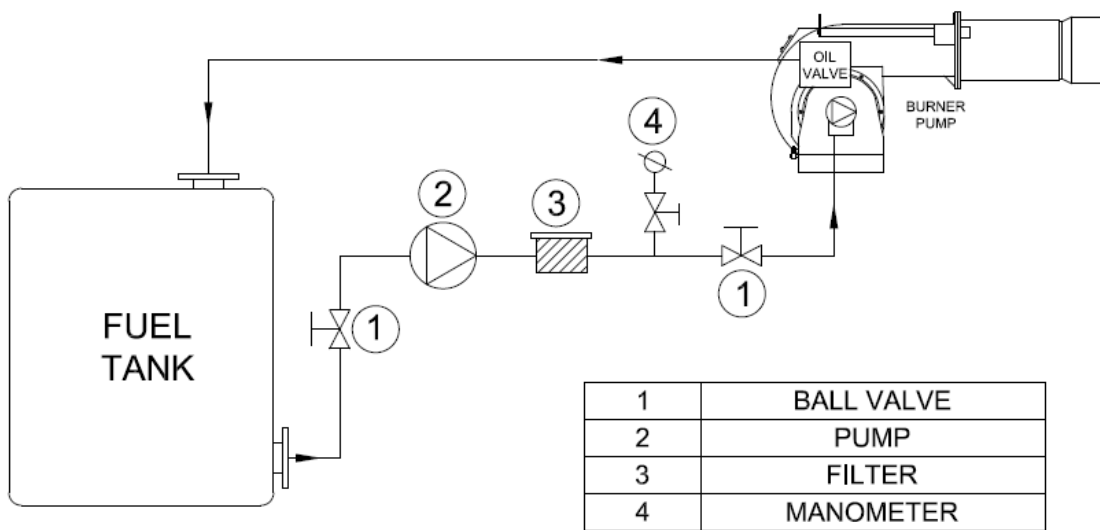

9. MAINTENANCE

9.1. Weekly Maintenance

Weekly maintenance is a routine cleaning and adjustment procedure which is performed to ensure smooth and continuous operation of the system. Burner components must be adjusted after each maintenance work in accordance with the instructions. Otherwise, the burner cannot be operated efficiently.

- Clean all filters in fuel ring system.
- Clean fuel nozzle of the burner.
- If the fin spaces and surface of the diffuser are covered with particles and formed a layer, clean it with a wire brush.
- Clean heads of ignition electrodes. Check by performing manual ignition, adjust the distance between the ignition electrode and diffuser according to the adjustment instructions.

9.2. Monthly Maintenance

Monthly maintenance is a more comprehensive maintenance compared to weekly maintenance, where general checks of burner and peripheral components are performed to prevent possible faults. After completion of maintenance and adjustment processes, make sure to perform a combustion analysis.

- Clean the filters on the fuel line to the burner.
- Clean fuel nozzle of the burner.
- Clean the surface of the diffuser.
- Clean flame pipe.
- Check all wiring points. Tighten loose connections.
- Clean the solenoid valves.
- Clean the photocell.
- Clean the dust and layers accumulated on the fan and air valves.
- Check pump pressure. Check if necessary (Light Oil: 14 bar)
- Check ignition electrodes. Adjust it if necessary. Check ignition cables and sockets.
- Perform cleanliness control of inside panel. Clean if necessary.
- Check all bolts of the burner. Tighten loose bolts.
- After starting the burner and adjusting air klappe, perform flue gas analysis and check if there is an ideal combustion.

9.3. Seasonal Maintenance

Comprehensive maintenance work when the burner is re-started after long periods of shut-down or interruptions. After completion of maintenance and adjustment processes, make sure to perform a combustion analysis.

- Check insulation resistance of electric motor.
- Make surface cleaning of ignition electrodes and porcelains. Replace cracked or broken porcelains.
- Clean air fan and clamps.
- Check the operating function.
- Check cleanliness of the nozzle. Replace it if necessary.
- Clean the N.C. solenoid valve. Measure the coil winding resistance.
- Clean the strainer (filter) under the pump cover.
- Clean the photocell.
- Clean fuel filter. Replace it if necessary.
- Check boiler thermostats.
- Check cleanliness of boiler inside and clean if necessary.

9.4. Installation and Disassembly Instructions for Maintenance Purposes

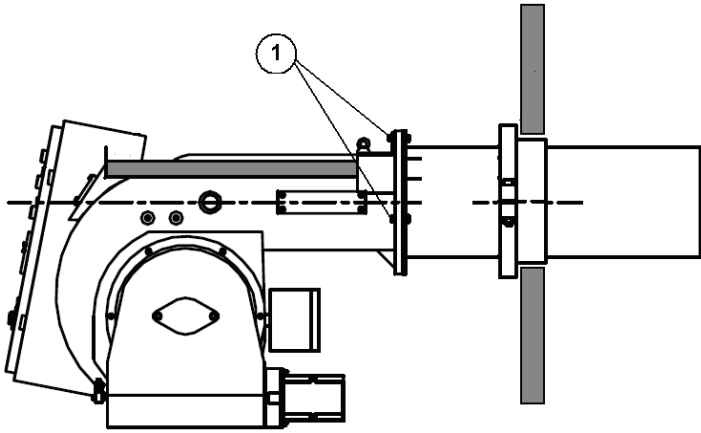

1. Remove 3 bolts connecting the burner body to the flame tube

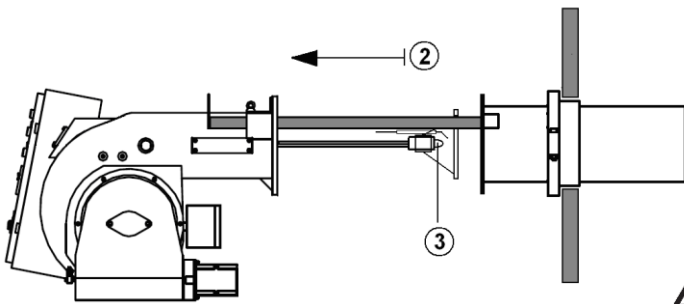

2. Pull the burner body back
3. Remove and perform maintenance of fuel nozzle, diffuser and ignition electrodes.



Be careful to connect the components correctly during installation after maintenance.

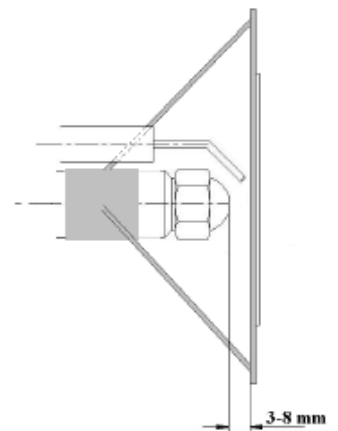
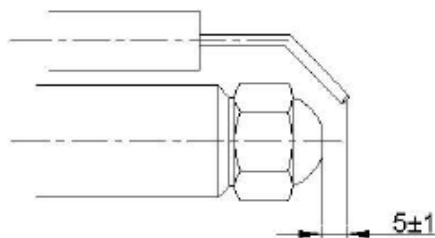
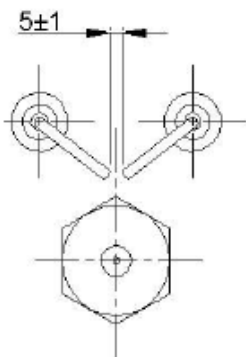

Perform the installation by following the reverse of the method you have followed during disassembly.

10. TROUBLESHOOTING

Problem	Cause	Explanation-Suggestion
Burner cannot be commissioned	Fuel is cut or does not come	Fuel valve might be closed. Open the valve.
	Fuse failure	Check burner power supply. The fuse on the main panel or the fuse on the burner might be tripped.
	Relay failure	Reset the thermal relay. Check adjustment of the thermal relay according to the current in motor label. If the failure is not removed, replace the thermal relay.
	Boiler thermostat, pressure switch failure	If there is a problem with the burner thermostats, pressure switches and steam tank this may be due to an unadjusted or faulty water level device; adjust it and if broken, replace it.
Flame appears and goes into failure mode.	Fuel pressure error	Circuit fuel pressure might have dropped.
	Photocell failure	Photocell may be faulty or contaminated. Remove and clean..
	Program relay failure	Replace it with a new one.
Burner starts up, but fails after 10 seconds.	Program relay failure	Replace it with a new one.
	Fan motor failure	Check fan motor coils, motor contactor and outlet from program relay.
Burner starts up, but fails after 30 seconds.	Fuel valve, fuel pressure drop	Fuel valve might be closed. Supply fuel pressure might be low. Check fuel inlet manometer.
	Ignition electrode failure	Ignition electrodes might be misadjusted or ignition cables might have come out of their terminals. Adjust ignition electrodes with a distance of 3-5 mm. between them.
Boiler cover is overheating.	Sealing problem	Ensure sealing between the boiler cover and burner. If required, use insulating material between the boiler connecting flange and boiler cover.

11. PERIODICAL FLUE GAS MEASUREMENT REPORT								
Fuel Consumption (kg/h)	CO (ppm)	O₂ (%)	CO₂ (ppm)	NO_x (ppm)	Yield (%)	Flue Temp. (°C)	Date	Signature

12. AFTER-SALES SERVICES

Dear Customer,

We believe that providing a good service is as important as providing a good product. Therefore, we continue offering wide range of comprehensive services to our conscious customers.

Our contact details for your requests and complaints

Esentepe Mah.Milangaz Cad. No:75 K:3

Kartal Monumento Plaza

KARTAL/İSTANBUL/TÜRKİYE

Tel: +90 216 442 93 00

Fax: +90 216 370 45 03

Factory Contact Details

Türkgücü OSB

Bülent Ecevit Bulvarı No:11

ÇORLU/TEKİRDAĞ/TÜRKİYE

Tel: +90 282 685 44 80-81

Fax: +90 282 685 42 09

Also you can contact with us:

Web site : www.ecostar.com.tr

E - mail : servis@ecostar.com.tr



Please observe the following recommendations.

- Use the product in accordance with the principles of this manual.
- For any service demands regarding the product, please contact our Service Center from the abovementioned phone numbers.
- Upon your purchase, register your warranty certificate during installation.

