

PROCESS BURNERS DUAL FUEL (GAS-HEAVY OIL) INSTALLATION, OPERATING AND MAINTENANCE MANUAL

ONE STAGE, TWO STAGE AND MODULATING OPERATION

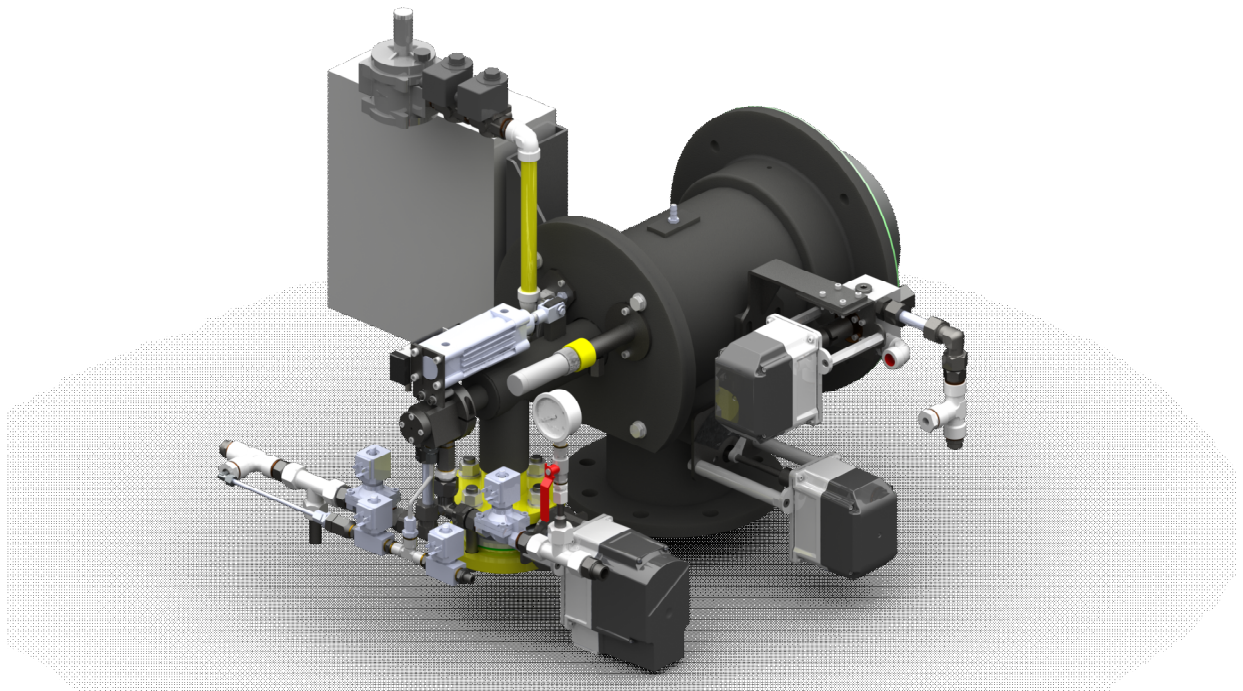

FPB 200
FPB 300
FPB 400
FPB 550
FPB 870
FPB 1200
FPB 1600
FPB 2000
FPB 2500
FPB 3500
FPB 5000

DEAR USER,

ECOSTAR FPB 200, FPB 300, FPB 400, FPB 550, FPB 870, FPB 1200, FPB 1600, FPB 2000, FPB 2500, FPB 3500, FPB 5000 Dual Fuel (Gas-Heavy Oil) process burners are prepared and manufactured according to the latest technical developments and safety rules. It is easy to use for our customers.

We recommend that you read this manual and safety warnings thoroughly before the use of the device in order to ensure safe, cost effective and environmental-friendly use.

If you encounter any issue that is not explained clearly in this manual or you could not understand, please contact with our service department.

We thank you for choosing ECOSTAR brand.









This Operating Manual is an integral part of the burner and must be maintained in a plastic dossier and hung at a clearly visible place in the burner room.

CONTENTS

1.	WARNINGS.....	3
1.1.	Warning Symbols and Descriptions.....	3
1.2.	General Safety Rules.....	4
2.	TERMS OF WARRANTY	6
2.1.	Out of Warranty Conditions.....	6
3.	BURNER’S GENERAL FEATURES.....	7
3.1.	Purpose of Use and Work Limits of Burners	7
3.2.	Process Burner Components.....	9
4.	GAS, FLUE GAS AND HEATING WATER SCHEMA	10
5.	TECHNICAL DATA.....	11
5.1.	Capacity Table.....	11
6.	INSTALLATION	12
6.1.	Burner Installation Picture.....	12
7.	COMMISSIONING.....	13
7.1.	General Controls.....	13
7.2.	Combustion Adjustment.....	14
7.2.1.	Oil pump.....	15
7.2.2.	Gas Adjustment.....	15
7.2.2.1.	VGD 20 4011 - 5011 Series Gas Valve.....	15
7.2.2.2.	MB DLE Series Monoblock Gas Valve.....	16
7.2.2.3.	MB ZRD(LE) 405 – 412 Series Gas Valve.....	18
7.3.	Fuel Diagrams.....	19
7.4.	Air pressure switch adjustment.....	22
7.5.	Servomotor Adjustment	22
7.6.	Program Relay	27
7.7.	Heavy Oil Burner Fuel Ring Line.....	27
7.8.	Gas Pass Equipment Required in Gas Line.....	28
8.	MAINTENANCE	30
8.1.	Weekly Maintenance.....	30
8.2.	Monthly Maintenance	30
8.3.	Seasonal Maintenance.....	31
9.	TROUBLESHOOTING.....	32
10.	PERIODICAL FLUE GAS MEASUREMENT REPORT.....	33
11.	AFTER SALES SERVICES.....	34
12.	NOTES	35

1. WARNINGS

1.1. Warning Symbols and Descriptions

Symbols	Symbol Descriptions
	Important information and useful hints.
	Warning of danger to life or property.
	Warning of electrical voltage.
	Product handling information.
<p data-bbox="368 1167 400 1196">P_F</p>	Impulse connection detecting combustion chamber pressure
<p data-bbox="368 1317 400 1346">P_L</p>	Impulse connection detecting combustion air pressure
<p data-bbox="360 1467 408 1496">P_{BR}</p>	Impulse connection detecting burner gas head
 <p data-bbox="320 1597 539 1671">CLEAN THE GAS BURNER. CLEAN GAS LINE. ЧИСТАЯ ЛИНИЯ ГАЗ.</p>	"Clean the gas line" warning on gas line.
   	Carry in an upright position. Fragile Item. Protect against water.

1.2. General Safety Rules

- All personnel engaged in installation, disassembly, commissioning, operation, control, maintenance and repair should have received the necessary training and fully read and understood this manual.
- No changes that might damage the safety of the burner unit must be made by persons and/or organizations on the burner unit.
- All operation, commissioning and installation works (except for burning adjustment) should be carried out when the burner is not operating and after disconnecting the power supply. Noncompliance with these rules may lead to serious bodily injuries and even death by electrical shocks or uncontrolled flame formation.
- Repairs concerned with safety elements should be carried out only by the manufacturing company.
- The device should never be used by children, mentally handicapped and inexperienced persons.
- Children must not be allowed to play with the device.
- Keep the device away from explosive and flammable materials.
- Device must intake air, ventilation and air discharge holes must not be closed.



If you sense scent of gas;

- Shut down valves of all gas devices.
- Open all doors and windows.
- Do not turn on electric devices or do not turn them off if they are working.
- Do not use burner derived tools such as match and lighter.
- Inform the gas company.



Do not store any inflammable materials in boiler room.



Wear hearing protectors if there is noise in boiler room.



In case of fire or other emergency;

- Switch off the main switch
- Close the main fuel shut-off valve outside the plant.
- Take appropriate actions



Install burner firmly. Vibration may damage burner or its components.



Keep boiler doors closed while starting burner and during burner operation.



During the first commissioning of the burner or in case of any revision carried out in the electrical system or motor cables by any reason, direction of the fan rotation must certainly be checked by the authorized technical service.



For products that have not been commissioned or started more than 6 months, before activating the servomotor;

In gas, air dampers and oil regulators, servomotor and damper connections must be checked to ensure that they are free running in spite of immobility and oil freezing.



In products used in high temperature oven applications; When the burners are not operated / are switched off, The air flaps must be set to remain in the half-open position, to prevent the burner components being damaged by hot air.



BURNER ROOM

Install the burner in a suitable room/floor with minimum external air openings and sufficient to ensure perfect combustion, in compliance with current regulations.

Never obstruct air openings of the burner room, burner fan intake vents or air ducts in order to prevent:

- a. The build up of toxic / explosive gas mixtures in the burner room,
- b. Combustion with insufficient air, resulting in hazardous, anti-economical and polluting operation.

The burner must be always protected from rain, snow and frost to prevent corrosion and paint deformations.

Keep the burner room clean and free of solid volatile substances, which could be sucked into the fan and clog the internal burner or combustion head air ducts.

2. TERMS OF WARRANTY

Main and auxiliary equipment and all components used in Ecostar Dual Fuel (Gas-Heavy Oil) process burners are guaranteed for 1 year by TERMO ISI SİST. A.Ş starting from the date of commissioning under the maintenance, adjustment, operating conditions and relevant mechanic, chemical and thermal effects explained herein.



Please note that this warranty is only valid if the device(s) is commissioned and maintained by our authorized services.



Our company reserves the right to make any modifications on the product and all instructions thereof for improvement purposes.

2.1. Out of Warranty Conditions

- Any damage arising out of or in relation to customers' non-compliance to their responsibilities with regards to installation, commissioning, operation and maintenance,
- Any damage arising out of or in relation to commissioning, repairs and maintenance carried out by unauthorized services,
- Any damage that may occur during transportation or storage of the product,
- Not preserving the product in its original packaging until the installation stage,
- Incorrect and poor electrical connections, Failures due to incorrect voltage applications, frequent repetition of voltage fluctuations,
- Any damage that may occur as a result of incorrect fuel usage or, foreign substances in the fuel used or using of the product without any fuel,
- Any damage that may occur due to foreign particles entered into the product during installation and operation,
- Failures due to incorrect device selection,
- Any damage to unit due to natural disasters,
- Devices without any warranty certificates,
- Warranty Certificates without the stamp and signature of the authorized dealer or service,
- Devices with any falsification on the warranty certificate or without an original serial number.
- The risks during transportation of device under the responsibility of customer belong to the customer.
- Presence of misuse faults are indicated in the reports issued by authorized service stations or our authorized agent, dealer, representative or our factory in case of unavailability of authorized service stations.
- Customers may apply consumer protection arbitrator committee with regards to this report and request for an expert report.

3. BURNER'S GENERAL FEATURES

ECOSTAR Dual Fuel (Gas-Heavy Oil) burners are designed and manufactured to work with liquid fuel with max. 2.5- 20 Cst (mm^2/s) viscosity. and Natural Gas / Liquid Petroleum Gas at gas pressures of min.20 mbar, max.300 mbar and at -%15 to +%10 of nominal voltages, under environmental temperature of max.60°C with rated capacity and burner pressure ranges.

3.1. Purpose of Use and Work Limits of Burners

- This product works at any load value equivalent to its max. capacity or covered by its capacity range;
 - High temperature industrial appliances.
 - In direct and indirect hot air generators,
 - -15 °C...+60 °C ambient temperature range,
 - 1N 230 VAC/3N 380VAC /50 Hz feed voltage (-%15...+%10) values,
 - Max. 95% relative humidity,
 - In well-ventilated open and closed spaces compatible with protection class IP 40.



This device must never be operated with open flame!

c St

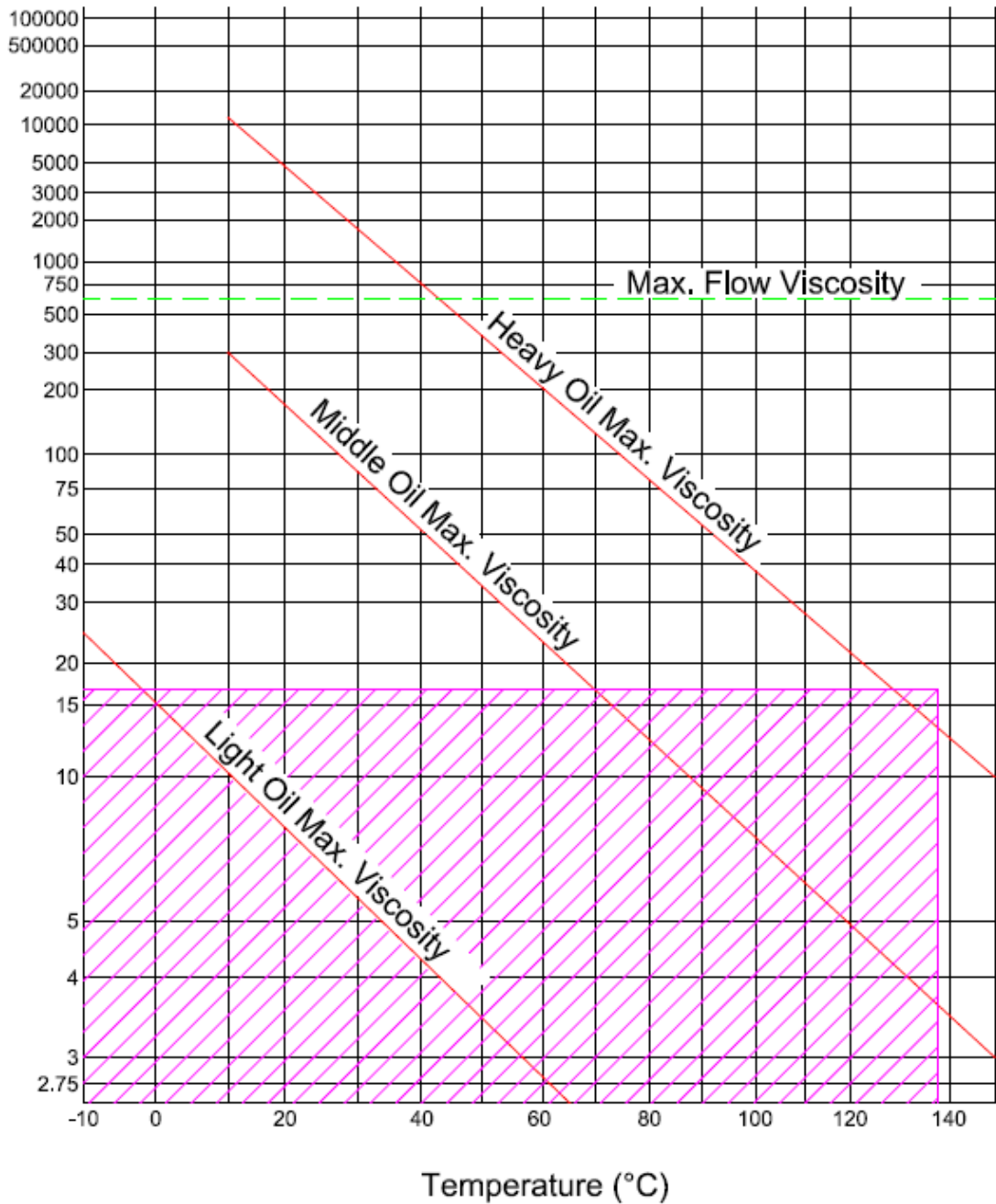

Temperature change of fuel used in ECOSTAR Dual Fuel (Gas-Heavy Oil) process burners dependent on viscosity



Operating Range

3.2. Process Burner Components

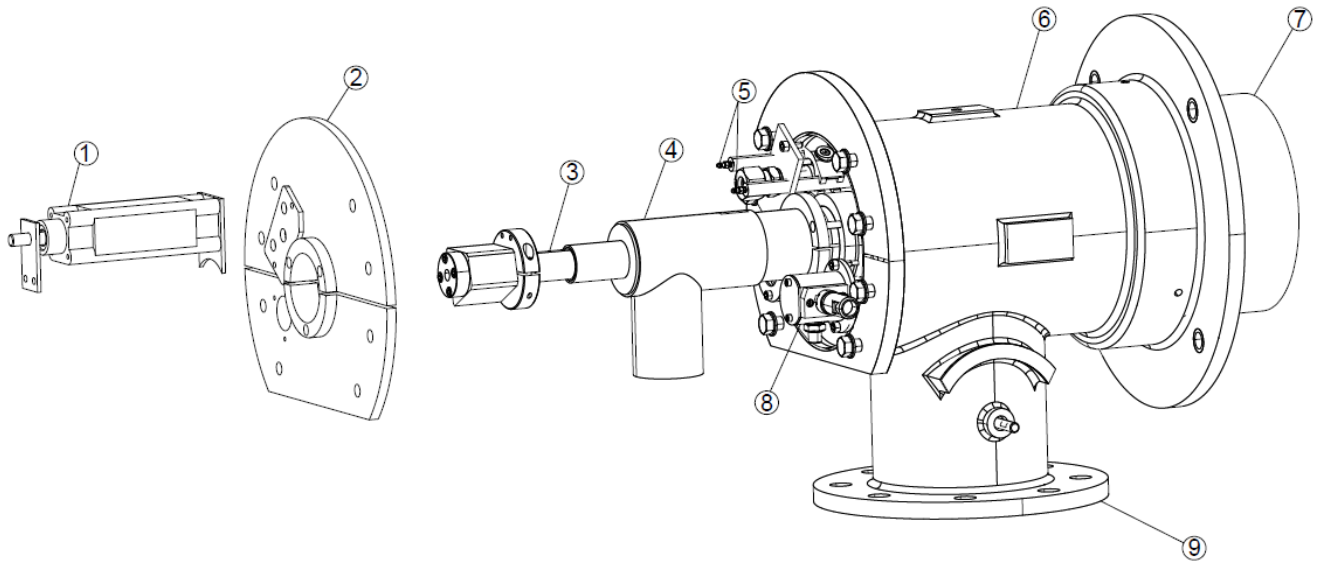

- 1- Pneumatic Cylinder*
- 2- Casing Flange
- 3- Nozzle
- 4- Gas Intake Pipe
- 5- Ignition Electrodes
- 6- Body
- 7- Flame Tube
- 8- Photocell
- 9- Combustion Air Intake

* It is available as an option.

4. GAS, FLUE GAS AND HEATING WATER SCHEMA

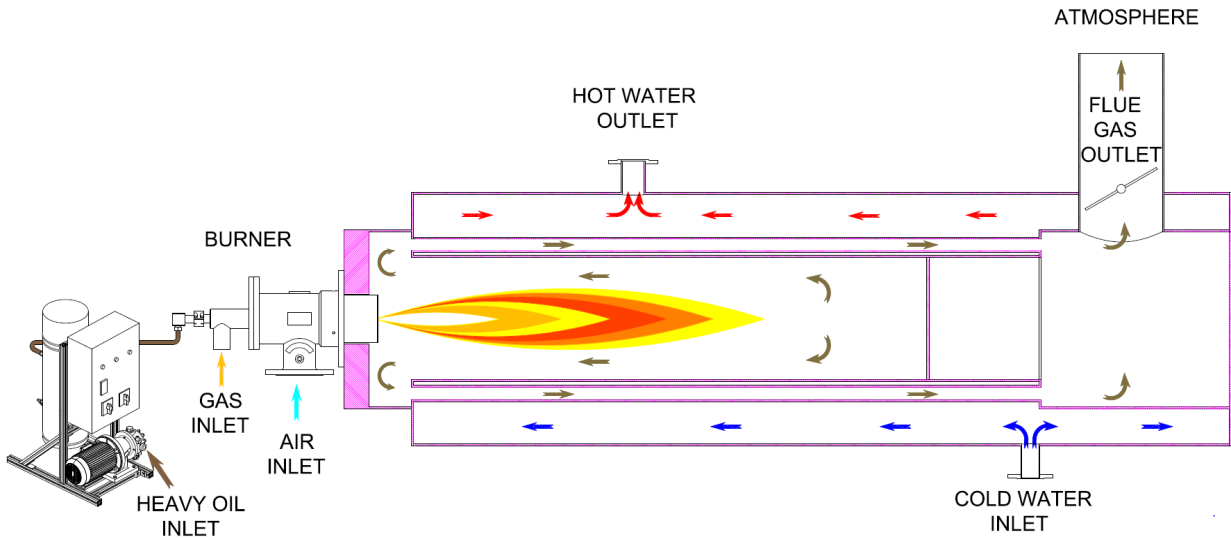

5. TECHNICAL DATA

5.1. Capacity Table

FPB PROCESS BURNERS											
	CAPACITY		CAPACITY		GAS CONSUMPTION		LPG CONSUMPTION		HEAVY OIL CONSUMPTION		FAN FLOW RATE
	Min.	Max.	Min.	Max.	Min.	Max.	Min.	Max.	Min.	Max.	
	Kcal/h		kW		Nm ³ /h		Nm ³ /h		kg/h		
FPB 200	40.000	200.000	46,5	232,6	4,8	24,2	1,8	8,9	4,1	20,7	350
FPB 300	60.000	300.000	69,8	348,8	7,3	36,4	2,7	13,3	6,2	31,1	500
FPB 400	80.000	400.000	93,0	465,1	9,7	48,5	3,6	17,8	8,3	41,5	650
FPB 550	110.000	550.000	127,9	639,5	13,3	66,7	4,9	24,4	11,4	57,0	900
FPB 870	174.000	870.000	202,3	1011,6	21,1	105,5	7,7	38,7	18,0	90,2	1.400
FPB 1200	240.000	1.200.000	279,1	1395,3	29,1	145,5	10,7	53,3	24,9	124,4	2.000
FPB 1600	320.000	1.600.000	372,1	1860,5	38,8	193,9	14,2	71,1	33,2	165,8	2.500
FPB 2000	400.000	2.000.000	465,1	2325,6	48,5	242,4	17,8	88,9	41,5	207,3	3.100
FPB 2500	500.000	2.500.000	581,4	2907,0	60,6	303,0	22,2	111,1	51,8	259,1	4.000
FPB 3500	700.000	3.500.000	814,0	4069,8	84,8	424,2	31,1	155,6	72,5	362,7	5.500
FPB 5000	1.000.000	5.000.000	1162,8	5814,0	121,2	606,1	44,4	222,2	103,6	518,1	7.800

H_u Natural Gas = 8250 kcal/Nm³

H_u LPG = 22500 kcal/Nm³

H_u Heavy Oil (S) = 9650 kcal/kg

6. INSTALLATION

6.1. Burner Installation Picture

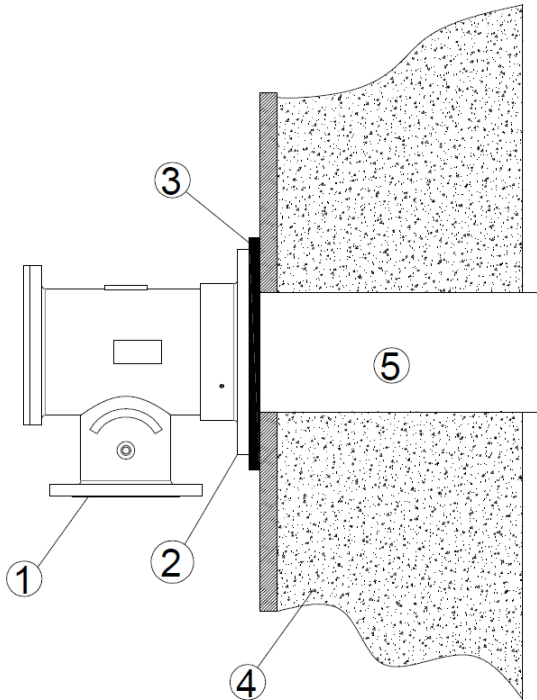

- 1 - Air inlet
- 2 - Connecting Flange
- 3- Sealing (Gasket)
- 4 - Refractory combustion chamber
- 5 - Flame tube

After completing the installation of the burner on the boiler:



Sealing between the combustion chamber and burner must be ensured



Device must be shipped in original packaging!



Do not lift the device holding from servomotor, gas valve, impulse pipes or pressure switch during installation!



Connect the oil feed pipes.



Connect the burner panel to the mains by a cable suitable for the rated power.



Clean the inside of fuel line thoroughly before installing the burner to the fuel line. Any damage that may occur due to solid objects and metal particles from the fuel line shall not be covered by our company.

7. COMMISSIONING

7.1. General Controls



Make sure to perform the following controls before commissioning the burner.

- Has heat demand been formed?
- Are the thermostat and other thermo-elements for control purposes working properly?
- Are the electrical connections correct?
- Is there electricity current?
- Is there gas?
- Has the boiler explosion lid been controlled?
- Is there sufficient air flow? (**capacity kW x 7 = ventilation section area cm²**)
- Has the boiler been installed correctly?
- Has the sealing of fuel lines been controlled?
- Check the temperature of the heavy-oil coming from the daily storage tank to the burner (should be 50°C ±5).
- Check the fuel line (are the pipe diameters and the pipe installation correct?).
- Check the fuel nozzles according to the capacity.

Commissioning order

Operating with Heavy Oil;

- Open the fuel tank valve.
- Open the valve upstream of the fuel filter.
- Open the pump's vent plug and place the manometer (0-40 bar).
- Switch on the burner's switch.
- When the burner starts up, the motor is activated and turns the pump at the same time.
- After the pre-purge, fuel is delivered from the nozzle. The fuel meets with the flame from the ignition electrodes and the combustion starts.
- Pump pressure is adjusted after the burner is burnt.
- If the burner has two stages, the switch is brought to position "2", and the capacity of the burner is increased through servomotor.
- Thermostat is adjusted upon request.
- For the safety of the system, check the thermostats and observe the deactivation of the burner.

Operating with Gas;

Operation of one-stage burner

- Open the main gas valve, check the gas pressure from the manometer at the valve. (max.300 mbar)
- Check the boiler thermostat or pressure switch settings.
- Bring the operating switch on the burner panel to position 1.
- Burner fan motor will be activated.
- Ignition will take place at the end of pre-purge process.
- 3 sec. later, the gas valve will be opened and combustion will occur.
- Flame control system (ionization) will start flame control.
- Burner is deactivated after the required capacity is formed.

Operation of two-stage burner

- Open the main gas valve, check the gas pressure from the manometer at the valve. (max.300 mbar)
- Check the boiler thermostat or pressure switch settings.
- Bring the operating switch on the burner panel to position 2.
- Burner fan motor will be activated.
- Ignition will take place at the end of pre-purge process.
- 3 sec. later, the gas valve will be opened and combustion will occur.
- Flame control system (ionization) will start flame control.
- Burner will switch to the second stage (max. capacity) according to the heat requirement.
- Burner is deactivated after the required capacity is formed.

Operation of a modulating burner

- Open the main gas valve; check max 300 mbar gas pressure from the manometer.
- Open operating switch on the burner panel.
- Switch on the modulating control switch.
- Switch automatic-hand switch to automatic.
- Check the temperature and pressure set values from the modulating control unit.
- Ignition will take place at the end of pre-purge process.
- 3 sec. later, the gas valve will be opened and combustion will occur.
- Flame control system (ionization) will start flame control.
- In modulating burner, the burner goes into max. capacity according to the signal from the modulating control unit.
- When the capacity increases, modulating control unit will switch the burner to min. capacity.
- If the boiler water temperature or steam pressure increases despite the operation of burner with min. capacity, the modulating control unit will stop the burner.

7.2. Combustion Adjustment

➤ Fuel nozzle

Use proper wrench in installation and dismantle of the fuel nozzle.

Use diesel oil to clean the fuel nozzle. Do not use thinner and its derivatives.

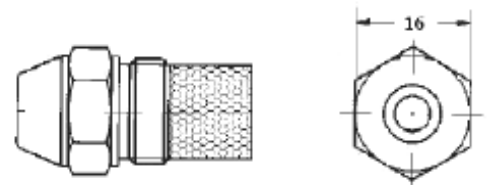

➤ Photocell

Check the photocell weekly. Clean the dust or fume stains on the glass of photocell by a dry cloth.

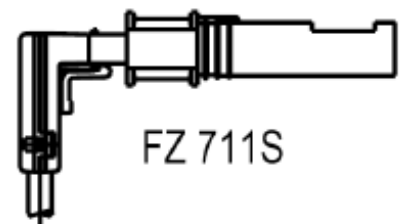

7.2.1. Oil pump

1. Oil inlet connection
2. Pressure adjustment screw
3. Oil return connection
4. Manometer connection
5. Pressurized oil outlet connection

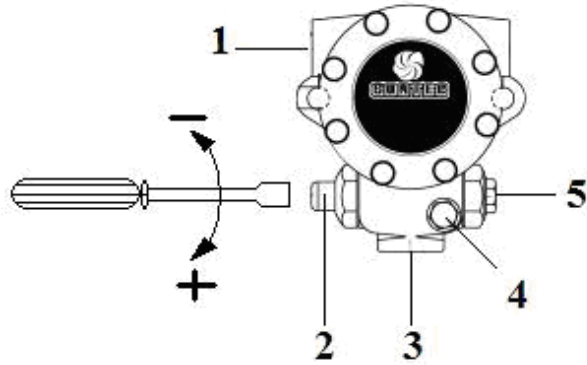

7.2.2. Gas Adjustment

Follow the instructions of the valve manufacturer during installation, dismantling and adjustment of the gas valve

7.2.2.1. VGD 20 4011 - 5011 Series Gas Valve

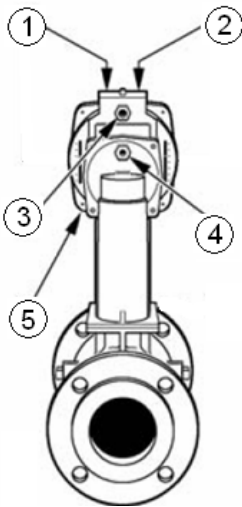

SKP 75 Connection Diagram

- 1 – Air-gas adjustment ratio
- 2 – Zero "0" point (start) adjustment
- 3 – Boiler counter pressure impulse connection
- 4 – Gas pressure impulse connection
- 5 – Air pressure impulse connection

7.2.2.2. MB DLE Series Monoblock Gas Valve

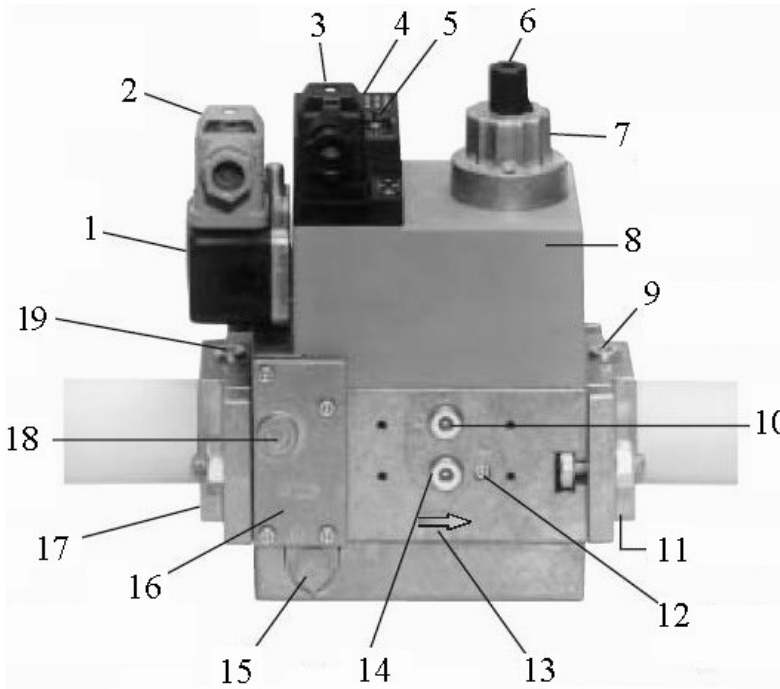

- 1- Pressure switch
- 2- Pressure switch electrical connection
- 3- Electrical connection of the valve
- 4- Operation gauge
- 5- The sealing ring
- 6- Set cover
- 7- Hydraulic disk brakes or settings
- 8- Coil
- 9- Measuring element connection (1/8)
- 10- Measuring element connection (1/8)
- 11- Output flange
- 12- Measuring element connection (1/8)
- 13- Gas flow way
- 14- Measuring element connection (1/8)
- 15- The vent plug
- 16- Filter chamber cover
- 17- Inlet flange
- 18- Measuring element connection (1/8)
- 19- Measuring element connection (1/8)

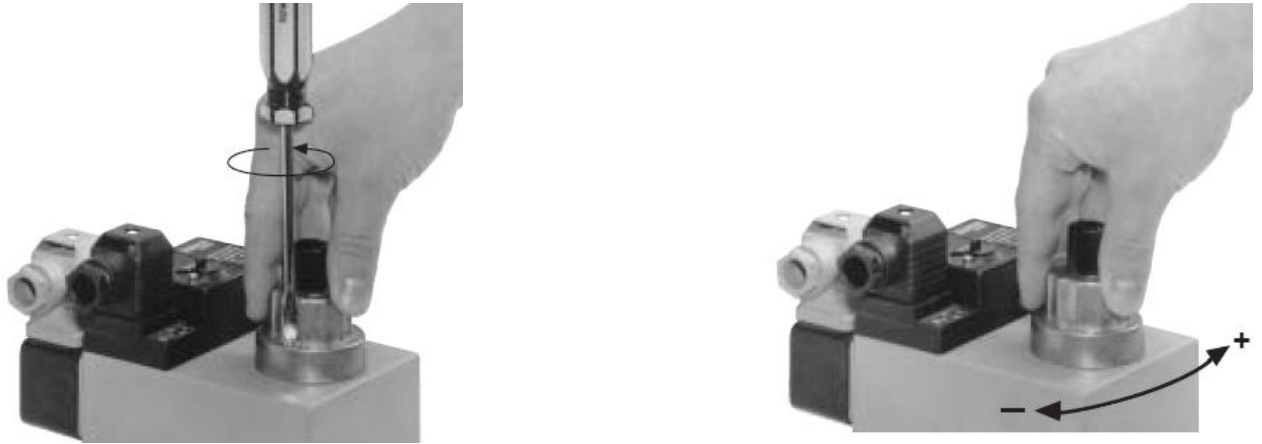

- Consider the below torque values for bolts tightened on the valve.
- Tighten flange bolts according to cross ordering and use proper tools.
- Sealing and function check must be performed if the valve is dismantled and re-installed over the line due to any reason.
- Before dismantling the valve from the line, you can perform filter replacement according to the below order.
 - Cut off the gas flow (turn off the ball valve)
 - Remove the 4 bolts (1,2,3,4) on the cover seen in the picture and take out the cover (5).
 - Take the filter cartridge (6) out of its socket and replace with a new one
 - Close the cover and tighten the bolts. In frequently performed filter replacement operations, use M4x14 bolt instead of self-tapping bolts used for fixing the cover.
 - Perform sealing and function control

Max. torque values;

M 4	M 5	M 6	M 8	G 1/8	G 1/4	G 1/2	G 3/4
2,5 Nm	5 Nm	7 Nm	15 Nm	5 Nm	7 Nm	10 Nm	15 Nm

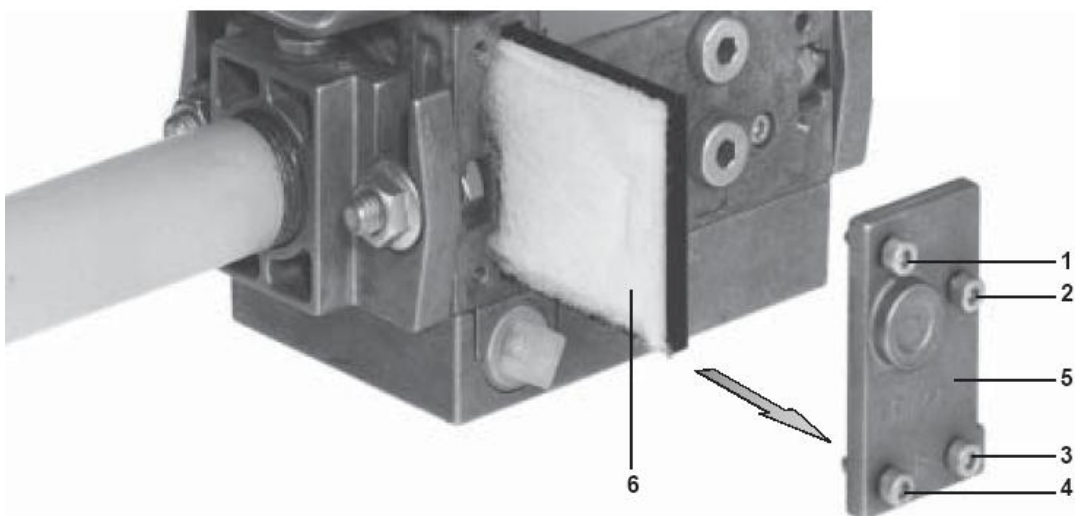

7.2.2.3. MB ZRD(LE) 405 – 412 Series Gas Valve

GasMultiBloc[®]

**Combined regulator and
safety shut-off valves
Two-stage function**

MB-ZRD(LE) 405 - 412 B01

DUNGS[®]
Combustion Controls

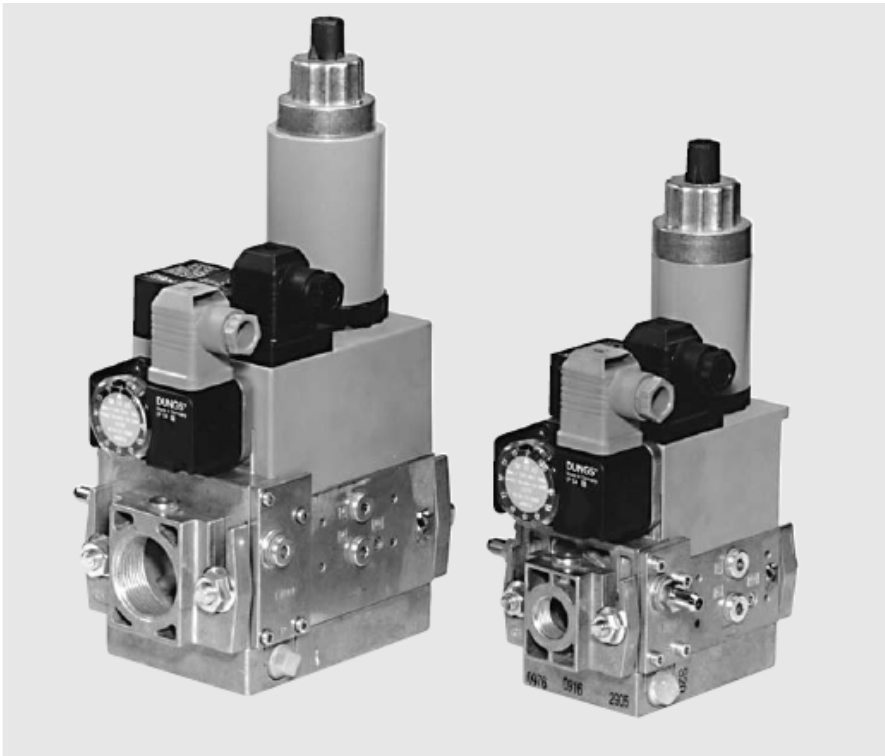

Technical description

The DUNGS GasMultiBloc[®] integrates filter, regulator, valves and pressure switches in one compact fitting.

- Dirt trap: microfilter
- One regulator and two main valves: B01
- One one-stage valve and one two-stage valve
- One valve is fast opening, one valve is slow or fast opening
- Solenoid valves up to 360 mbar (36 kPa) as per DIN EN 161 Class A Group 2
- Sensitive setting of output pressure by proportional regulator as per DIN EN 88 Class A Group 2
- High flow rates with low pressure drop
- DC solenoid drive interference degree N
- Main volume restrictor and partial volume restrictor at valve V2
- Hydraulic opening delay
- Flange connections with pipe threads as per ISO 7/1
- Simple mounting, compact, light-weight

The modular system permits individual solutions by using external ignition gas tap in connection with separately controlled valves, by adding a valve proving system, mini/maxi pressure switches, pressure limiters, limit switch and closing stroke limiter at valve V2, regulator blocking for liquid gas applications.

Application

The modular system permits individual solutions in gas safety and regulator engineering. Suitable for gases of families 1, 2, 3 and other neutral gaseous media.

Approvals

EC type test approval as per EC Gas Appliance Directive:
MB-ZR...405-412 B01 CE-0085 AP 3156
EC type test approval as per EC Pressure Equipment Directive:
MB-ZR...405-412 B01 CE0036
Approvals in other important gas consuming countries.

7.3. Fuel Diagrams

➤ One Stage Heavy Oil Burner Fuel Circuit

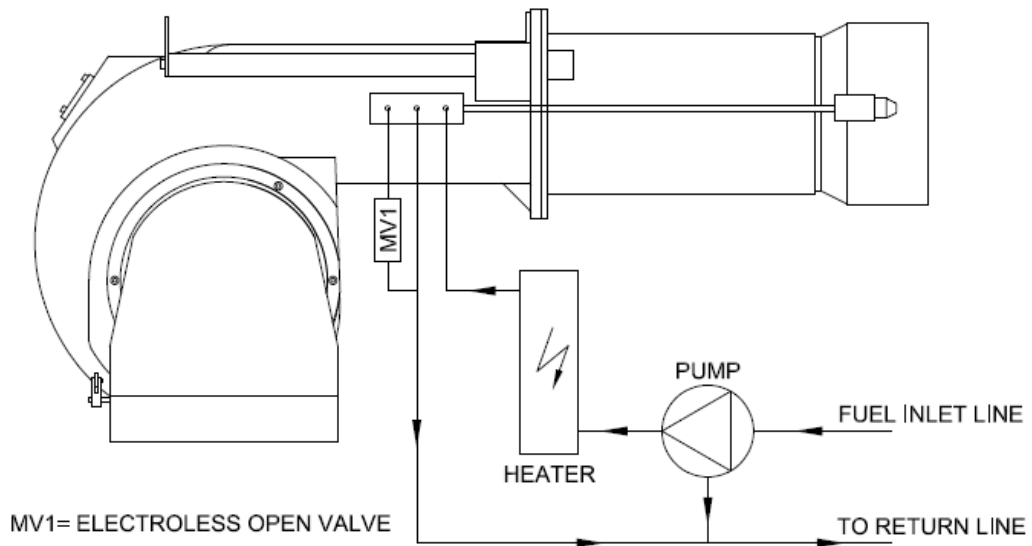

➤ Two Stages Heavy Oil Burner Fuel Circuit

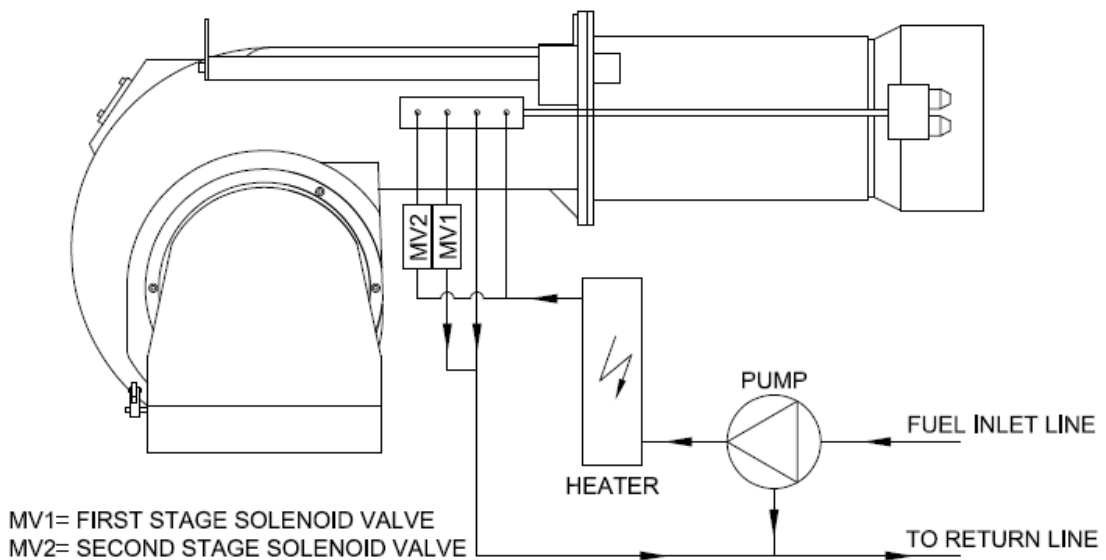

➤ **Modulating Heavy Oil Burner Fuel Circuit**

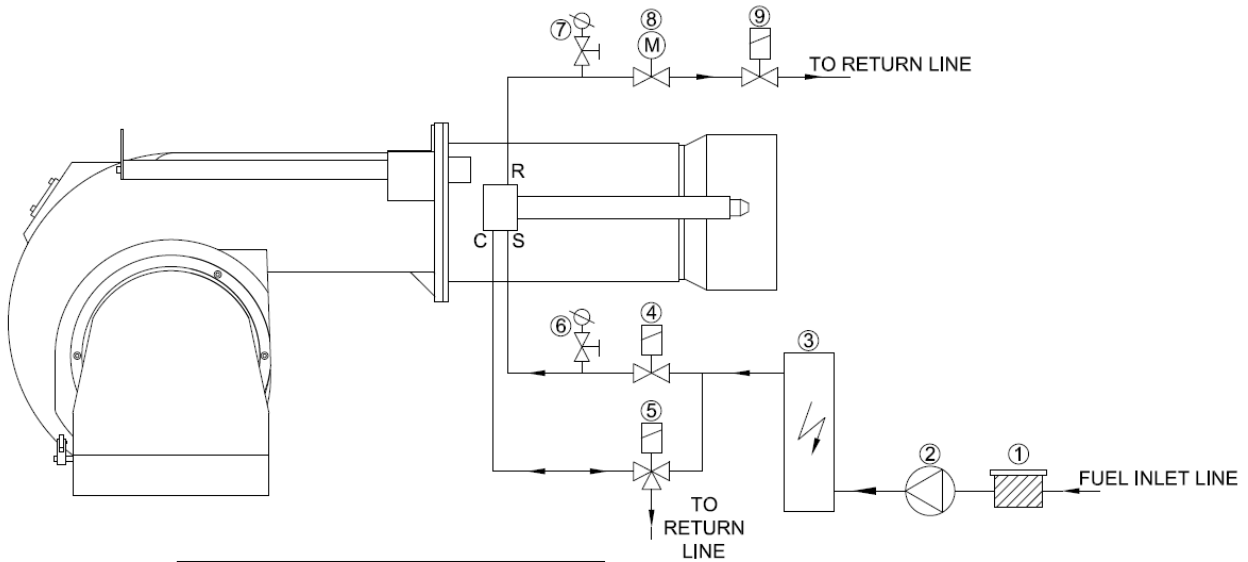

1	FILTER
2	PUMP
3	HEATER
4	FUEL INLET VALVE
5	HYDRAULIC CONTROL VALVE
6	MANOMETER
7	MANOMETER
8	OIL REGULATING VALVE
9	FUEL RETURN VALVE



CAUTION!

- **End of the line to the main tank must be open to the atmosphere and line pressure must be zero, otherwise no healthy modulating operation can be ensured since the pressure, which is to form in return, will also affect nozzle pressure. Fuel may drop from nozzle end during stops.**
- **For good pulverization, periodically check durability of the o-ring. In the event of earing of the o-ring, fuel to the nozzle can by-pass and go directly to the return and reduces the working performance of the nozzle.**
- **Maximum operating pressure of the nozzle is 30 bars, while its maximum operating temperature is 140°C. These values should not be exceeded during working. Even if these out of control value are exceeded, nozzle must be taken to emergency maintenance and all O-rings must be replaced.**
- **Do not use solvent based materials (thinner and derivatives) during cleaning of the fuel nozzle; clean with gas oil or diesel oil. Fuel nozzle inner kit is very sensitive and even invisible deformations can reduce working performance; dismantling-installing work must be performed only by trained personnel.**
- **Spring has lost its function if dropping from fuel nozzle or fuel exit at large scale is observed when the nozzle performs circulation. It must be checked and replaced if necessary.**

➤ **Burner preheater**

1. Fuel inlet
2. Fuel outlet
3. Discharge
4. Fixing plate
5. Resistance
6. Thermostat bulb pipe
7. Housing cover

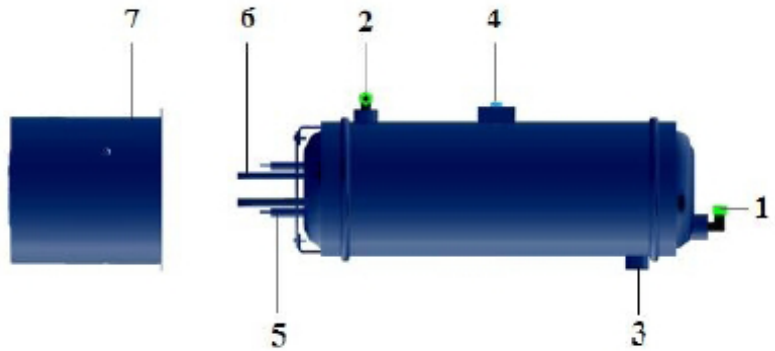

7.4. Air pressure switch adjustment

While the burner is working without any problem, the air pressure switch is adjusted to desired minimum pressure as follows.

- Unscrew the screw of the transparent cover and remove the cover.
- Turn the adjustment wheel in the direction to increase the pressure, note the pressure value at which the burner is failed.
- Set the pressure switch to a value 1 mbar lower than the pressure value at which the burner failed and close the pressure switch lid.
- It is recommended that this adjustment is carried out when the burner is at minimum load.



7.5. Servomotor Adjustment

➤ **SQN70**

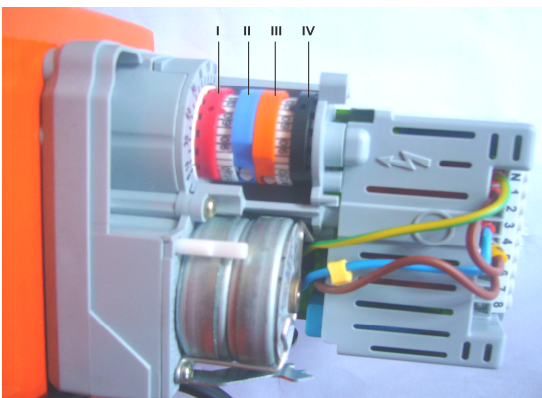

At Two-stage Burners;

- I. Red Cam: Adjusts 2nd level max. air.
- II. Blue Cam: Resets the clamp.
- III. Orange Cam: Adjusts 1st level min. air.
- IV. Black Cam: Adjusts 2nd level valve opening degree.

At Modulating Burners;

- I. Red Cam: Performance max. air adjustment.
- II. Blue Cam: Resets the clamp.
- III. Orange Cam: Performs min. air adjustment.
- IV. Black Cam: Not used.

➤ SQM10



- I. Cam: Opening
- II. Cam: Resets the clamp
- III. Cam: Commissioning air
- IV. V. VI. and VII. Cam not used

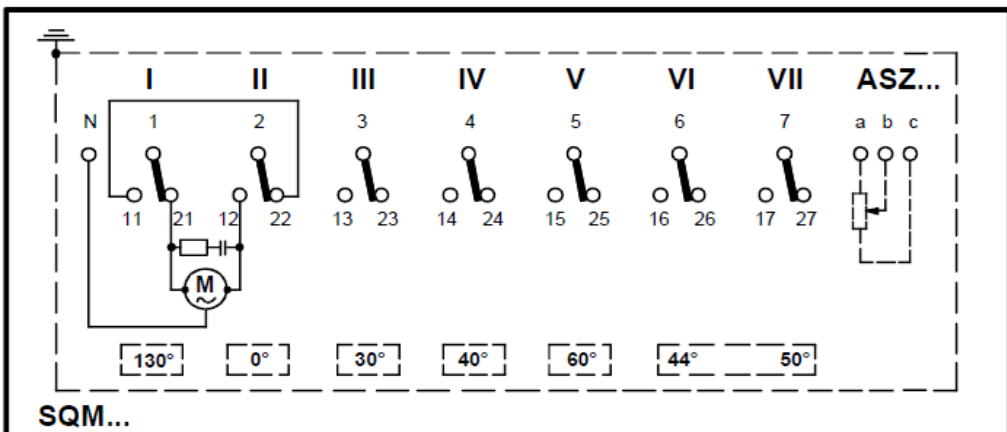
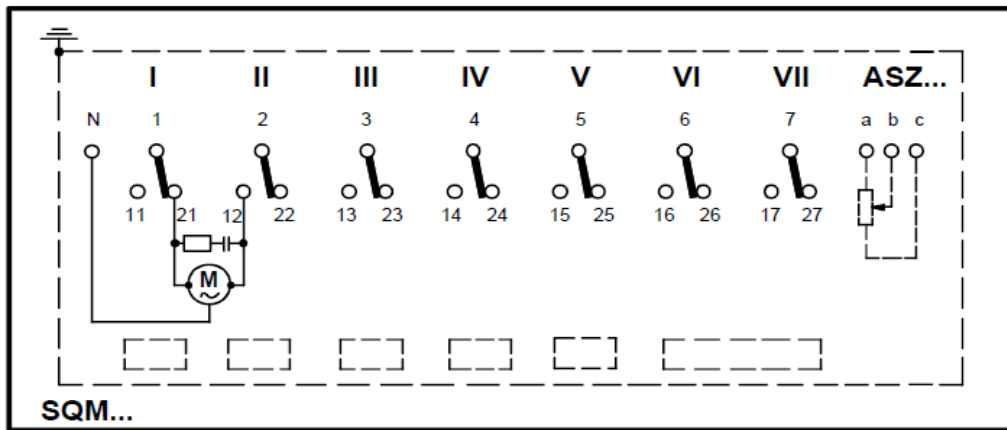

Do not open servomotor. Do not interfere with. It may damage servomotor or change burner settings.



Burner's actuators should not be installed closer to high temperature zones, max allowed ambient temperature should be 60 °C for actuator's operation safety

➤ **MODULATING MECHANISM ADJUSTMENT**

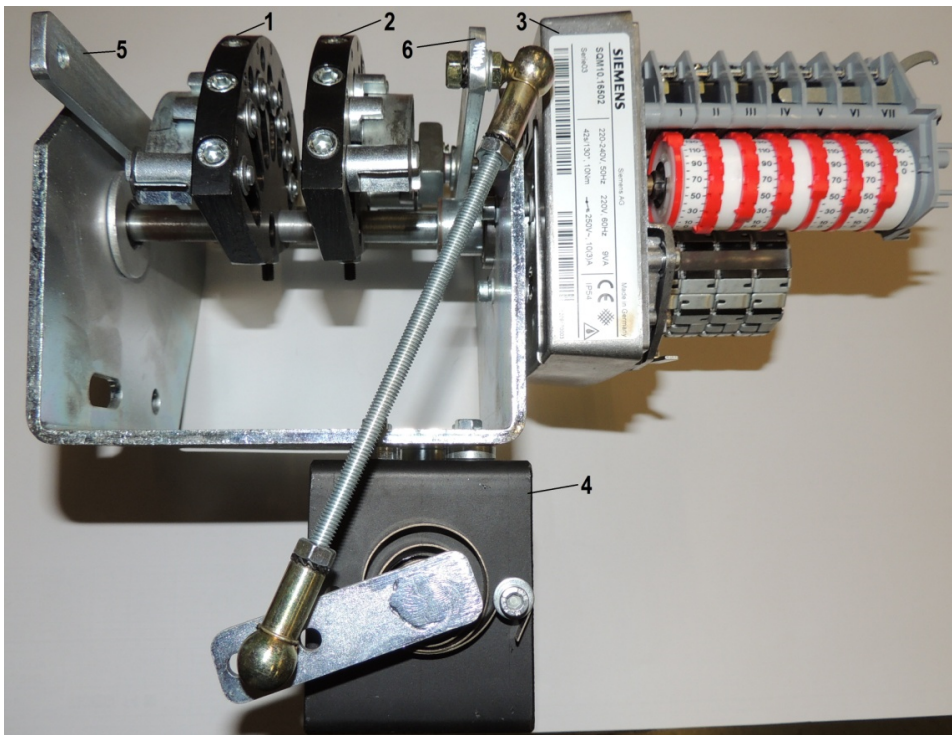

- 1- Air adjustment disk
- 2- Fuel adjustment disk
- 3- Servomotor
- 4- Fuel regulator
- 5- Air control lever
- 6- Fuel control lever

ADJUSTMENT:

1- Start positions prior to disc mechanism adjustment operation must be as follows:

- Servomotor: 0°
- Fuel adjustment disc at start position
- Air adjustment disc at start position
- Fuel regulator at position 10
- Air klappes at fully closed position: 0°

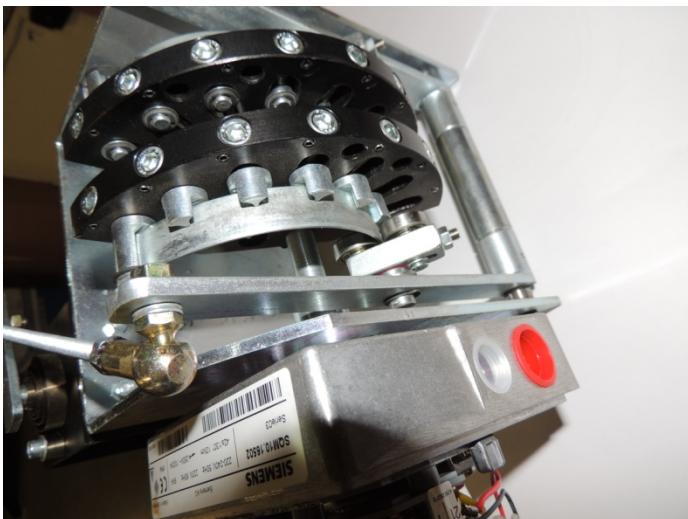

Start position for discs



Start position for fuel regulator

2 – If disc mechanism start positions are correct, start the burner and ensure that it activates in basic load. Detect min capacity activation fuel amount of the burner by checking min. return pressure. If the activation fuel amount is insufficient, set fuel regulator start adjustment to 9 or 8 value by changing spring adjustment from adjusting bolt on fuel disc number 2. When you start the burner again after this operation, you will see that your fuel return pressure has increased and hence activation fuel amount has risen.

3 – Slowly increase the capacity following burner basic load adjustment provided that modulating control device is in manual position. By setting 7 or 8 points during capacity increase, at these points:

- Measure emission values
- Record fuel return pressure
- Observe air klappe position
- Check fuel regulator scale value moves from 10 to 0.

4- If you haven't been able to reach the max capacity required by the boiler in 90° position of the air klappe and 0° position of the fuel regulator once you have completed the maximum adjustment, follow the below fuel regulator adjustment procedure:

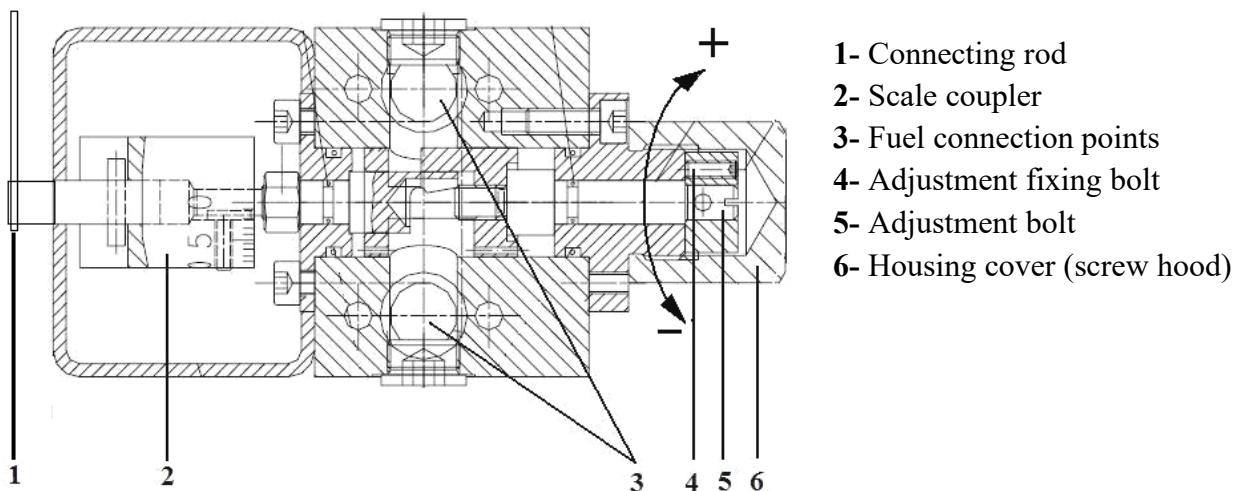

Fuel Regulator Adjustment

- 1- Remove the housing cover number 6
- 2- Loosen the fixing bolt number 4
- 3- When you rotate the shaft number 5 (when looked from the shaft end) clockwise, the pressure value you observe from return manometer will increase, and burner consumption will also increase since nozzle pressure increases.
- 4- When you rotate the shaft number 5 (when looked from the shaft end) anti-clockwise, the pressure value you observe from return manometer will decrease, and burner consumption will also decrease since nozzle pressure decreases.
- 5- When the adjustment is completed, make sure that the adjustment you have made is permanent by tightening the fixing bolt number 4.
- 6- Place the housing cover number 6.

5 - Set the burner to the correct capacity required by the boiler by considering the below nozzle pressure and consumption values.

Diagram valid for fuel nozzles having 45° spraying angle

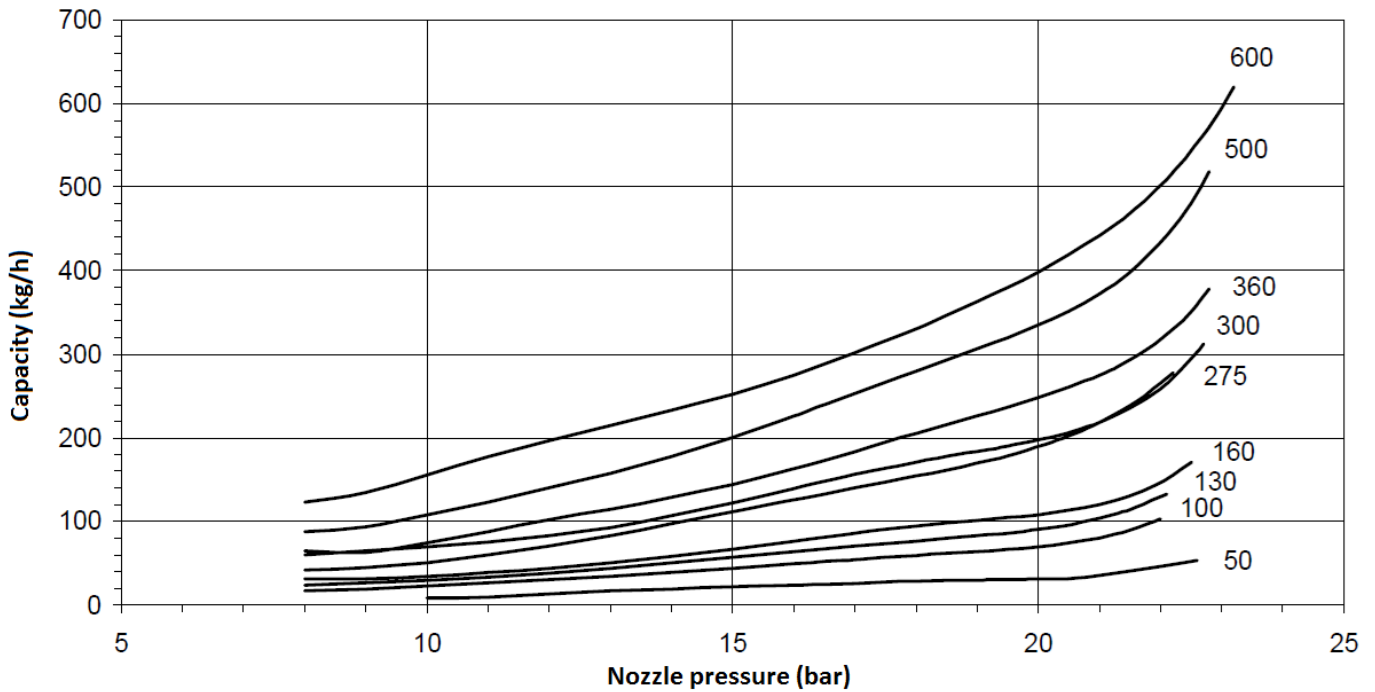
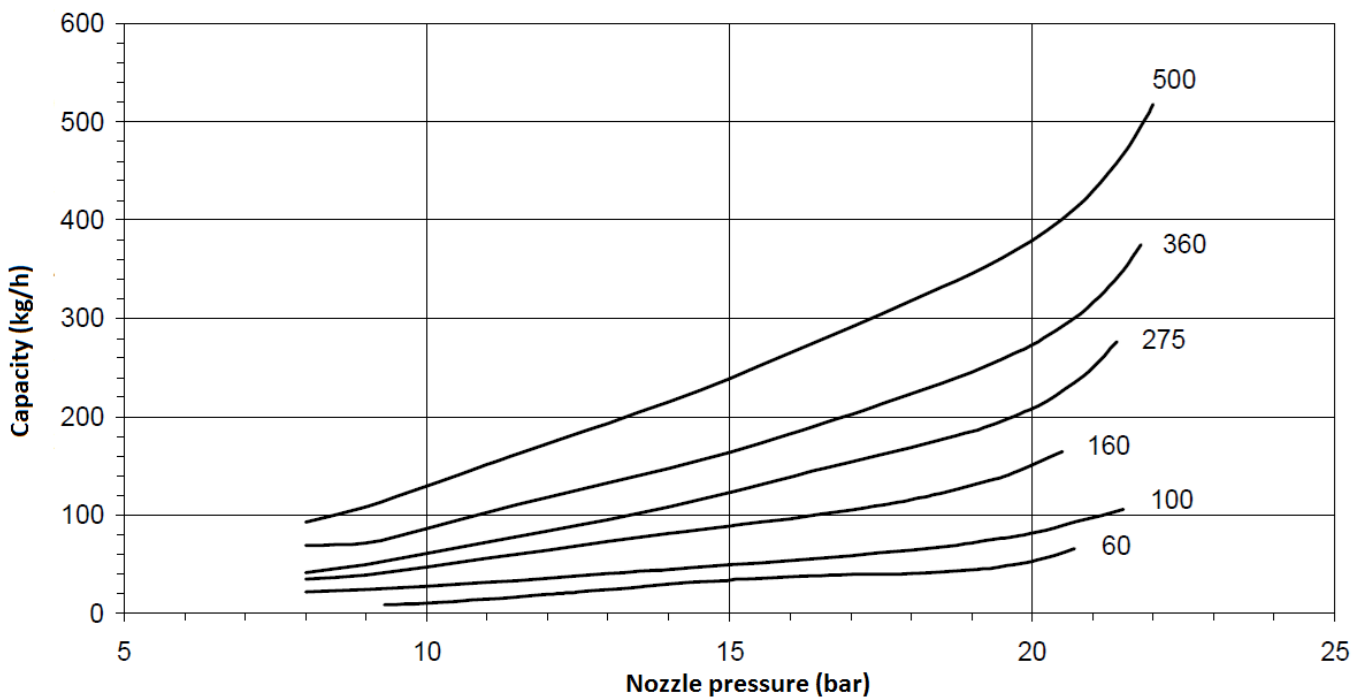

Diagram valid for fuel nozzles having 60° spraying angle



6 – Once the burner modulating adjustment is completed, set modulating control device to automatic position, change set values and observe capacity changes. Air and fuel will increase and decrease simultaneously according to the adjustment you previously made.

7.6. Program Relay

LFL 1.32



7.7. Heavy Oil Burner Fuel Ring Line

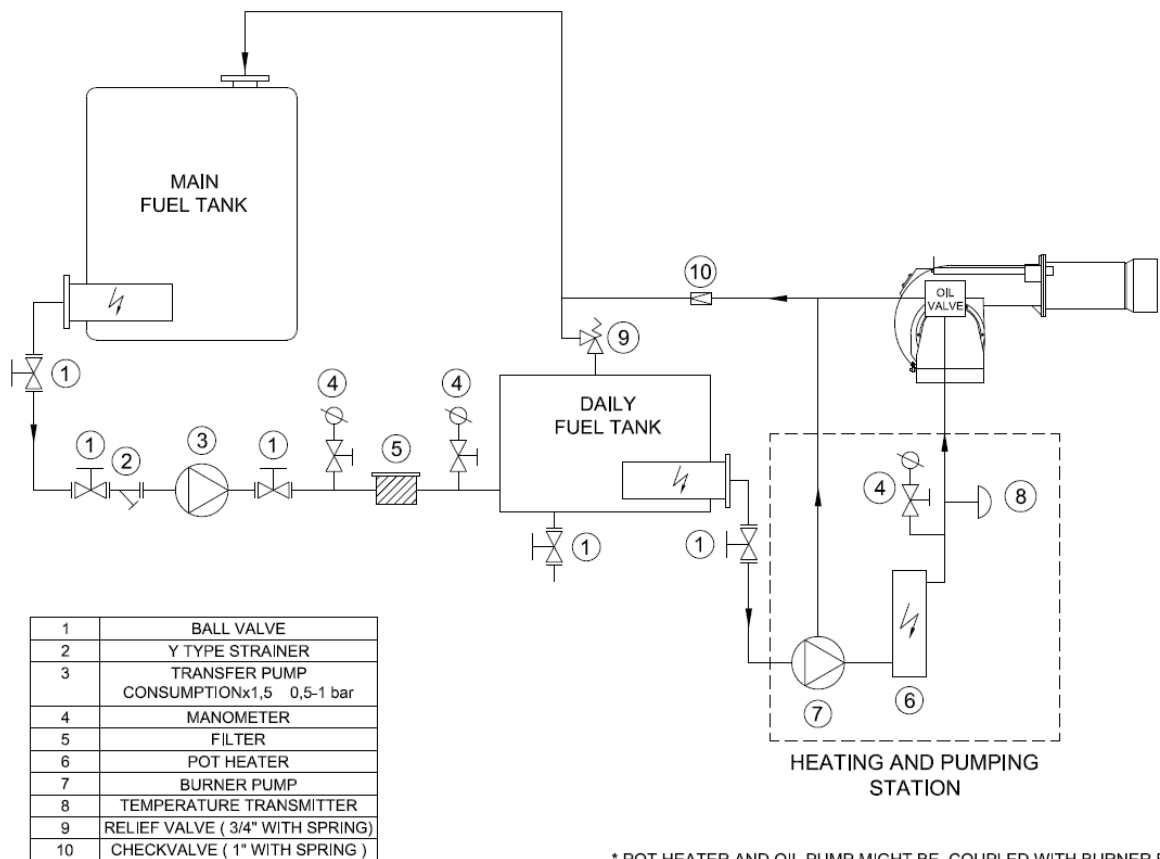

* POT HEATER AND OIL PUMP MIGHT BE COUPLED WITH BURNER BODY OR COME AS A SEPARATE FILTERING-PUMPING-HEATING GROUP ACCORDING TO BURNER CAPACITY.

7.8. Gas Pass Equipment Required in Gas Line

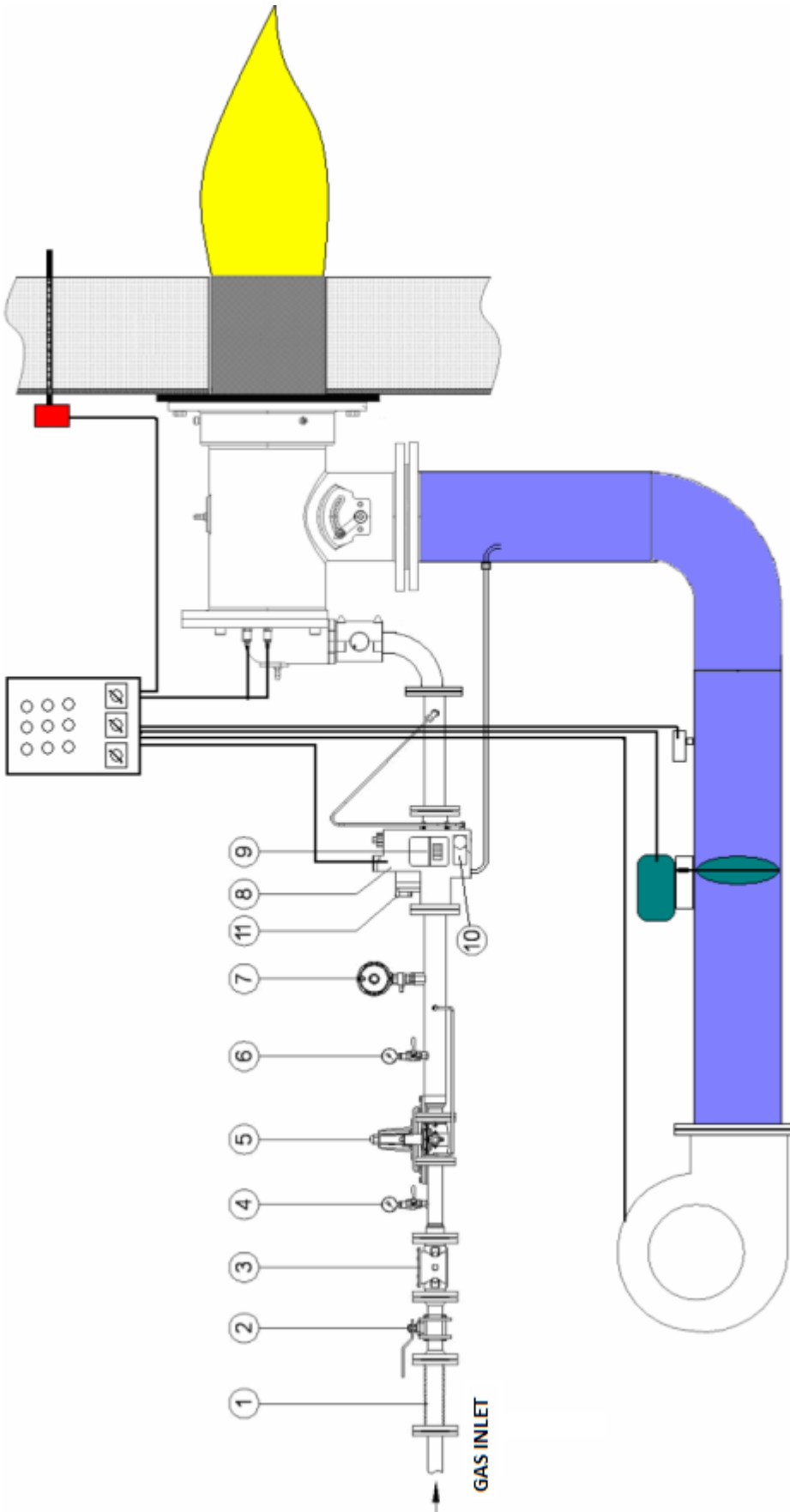

Pe < 300 mbar Q<1200kW	Pe > 300 mbar Q<1200kW	Pe < 300 mbar Q>1200kW	Pe > 300 mbar Q>1200kW
1- Compensator	1- Compensator	1- Compensator	1- Compensator
2- Ball valve	2- Ball valve	2- Ball valve	2- Ball valve
3- Gas filter	3- Gas filter	3- Gas filter	3- Gas filter
4- Inlet manometer + valve	4- Inlet manometer + valve	4- Inlet manometer + valve	4- Inlet manometer + valve
8 – Multi-block (safety and operation solenoids)	5- Regulator	8 – Multi-block (safety and operation solenoids))	5- Regulator
10- max. gas pressure switch	6- Outlet manometer + valve	9- Sealing Control Set	6- Outlet manometer + valve
11- min. gas pressure switch	7- Safety discharge valve	10- max. gas pressure switch	7- Safety discharge valve
	8 – Multi-block (safety and operation solenoids)	11- min. gas pressure switch	8 – Multi-block (safety and operation solenoids)
	10- max. gas pressure switch		9- Sealing Control Set
	11- min. gas pressure switch		10- max. gas pressure switch
			11- min. gas pressure switch

8. MAINTENANCE

8.1. Weekly Maintenance

Weekly maintenance is a routine cleaning and adjustment procedure which is performed to ensure smooth and continuous operation of the system. Burner components must be adjusted after each maintenance work in accordance with the instructions. Otherwise, the burner cannot be operated efficiently.

- Clean all filters in fuel ring system.
- Clean fuel nozzle of the burner.
- Check the burner gas tip.
- If the fin spaces and surface of the diffuser are covered with particles and formed a layer, clean it with a wire brush.
- Clean heads of ignition electrodes. Check by performing manual ignition, adjust the distance between the ignition electrode and diffuser according to the adjustment instructions.

8.2. Monthly Maintenance

Monthly maintenance is a more comprehensive maintenance compared to weekly maintenance, where general checks of burner and peripheral components are performed to prevent possible faults. After completion of maintenance and adjustment processes, make sure to perform a combustion analysis.

- Clean the filters on the fuel line to the burner.
- Clean fuel nozzle of the burner.
- Clean the surface of the diffuser.
- Clean flame pipe.
- Check all wiring points. Tighten loose connections.
- Clean the solenoid valves.
- Clean the photocell.
- Clean the dust and layers accumulated on the fan and air valves.
- Check pump pressure. Check if necessary (Heavy Oil: 18bar)
- Check ignition electrodes. Adjust it if necessary. Check ignition cables and sockets.
- Perform cleanliness control of inside panel. Clean if necessary.
- Check all bolts of the burner. Tighten loose bolts.
- Clean the filters on the main line and multiblock.
- Check the burner gas tip.
- Check gas line pressure, it must be the same with the first adjusted pressure, otherwise burner load and emission values will also have changed.

8.3. Seasonal Maintenance

Comprehensive maintenance work when the burner is restarted after long periods of shut-down or interruptions. After completion of maintenance and adjustment processes, make sure to perform a combustion analysis.

- Check insulation resistance of electric motor.
- Make surface cleaning of ignition electrodes and porcelains. Replace cracked or broken porcelains.
- Clean air fan and clamps.
- Check the operating function.
- Check cleanliness of the nozzle. Replace it if necessary.
- Clean the N.C. solenoid valve. Measure the coil winding resistance.
- Clean the strainer (filter) under the pump cover.
- Clean the photocell.
- Clean fuel filter. Replace it if necessary.
- Check boiler thermostats.

9. TROUBLESHOOTING

Problem	Cause	Explanation-Suggestion
Burner cannot be commissioned	Heavy Oil or Gas is cut or does not come	Heavy Oil or Gas valve might be closed. Open the valve.
	Fuse failure	Check burner power supply. The fuse on the main panel or the fuse on the burner might be tripped.
	Relay failure	Reset the thermal relay. Check adjustment of the thermal relay according to the current in motor label. If the failure is not removed, replace the thermal relay.
	Boiler thermostat, pressure switch failure	If there is a problem with the burner thermostats, pressure switches and steam tank this may be due to an unadjusted or faulty water level device; adjust it and if broken, replace it.
Flame appears and goes into failure mode.	Heavy Oil or Gas pressure error	Circuit heavy oil or gas pressure might have dropped.
	Photocell failure	Photocell may be faulty or contaminated. Remove and clean.
	Program relay failure	Replace it with a new one.
Burner starts up, but fails after 10 seconds.	Program relay failure	Replace it with a new one.
	Air pressure switch adjustment	Air pressure switch might be adjusted to a high value. There may be dirt in the air pressure switch. Air pressure switch might be broken.
	Fan motor failure	Check fan motor coils, motor contactor and outlet from program relay.
Burner starts up, but fails after 30 seconds.	Heavy Oil or Gas valve, heavy oil or gas pressure drop	Heavy Oil or Gas valve might be closed. Circuit heavy oil or gas pressure might have dropped. Check Heavy Oil or Gas inlet manometer.
	Ignition electrode failure	Ignition electrodes might be misadjusted or ignition cables might have come out of their terminals. Adjust ignition electrodes with a distance of 3-5 mm. between them.
Boiler cover is overheating.	Sealing problem	Ensure sealing between the boiler cover and burner. If required, use insulating material between the boiler connecting flange and boiler cover.

11. AFTER SALES SERVICES

Dear Customer,

We believe that providing a good service is as important as providing a good product. Therefore, we continue offering wide range of comprehensive services to our conscious customers.

For your suggestions, complaints and service requests
Esentepe Mah. Milangaz Cad. No:75 K:3
Kartal Monumento Plaza
KARTAL/İSTANBUL/TÜRKİYE
Tel: 444 8 326
Fax: +90 216 370 45 03

Factory Contact Details
Türkgücü OSB
Bülent Ecevit Bulvarı No:11
ÇORLU/TEKİRDAĞ/TÜRKİYE
Tel: +90 282 685 44 80-81
Fax: +90 282 685 42 09

Also you can contact with us:
Web site : www.ecostar.com.tr
E - mail : servis@ecostar.com.tr



Please observe the following recommendations.

- Use the product in accordance with the principles of this manual.
- For any service demands regarding the product, please contact our Service Center from the abovementioned phone numbers.
- Upon your purchase, register your warranty certificate during installation.

