

DUOBLOCK HEAVY OIL BURNERS INSTALLATION, OPERATING AND MAINTENANCE MANUAL

MODULATING OPERATION (MECHANICAL)

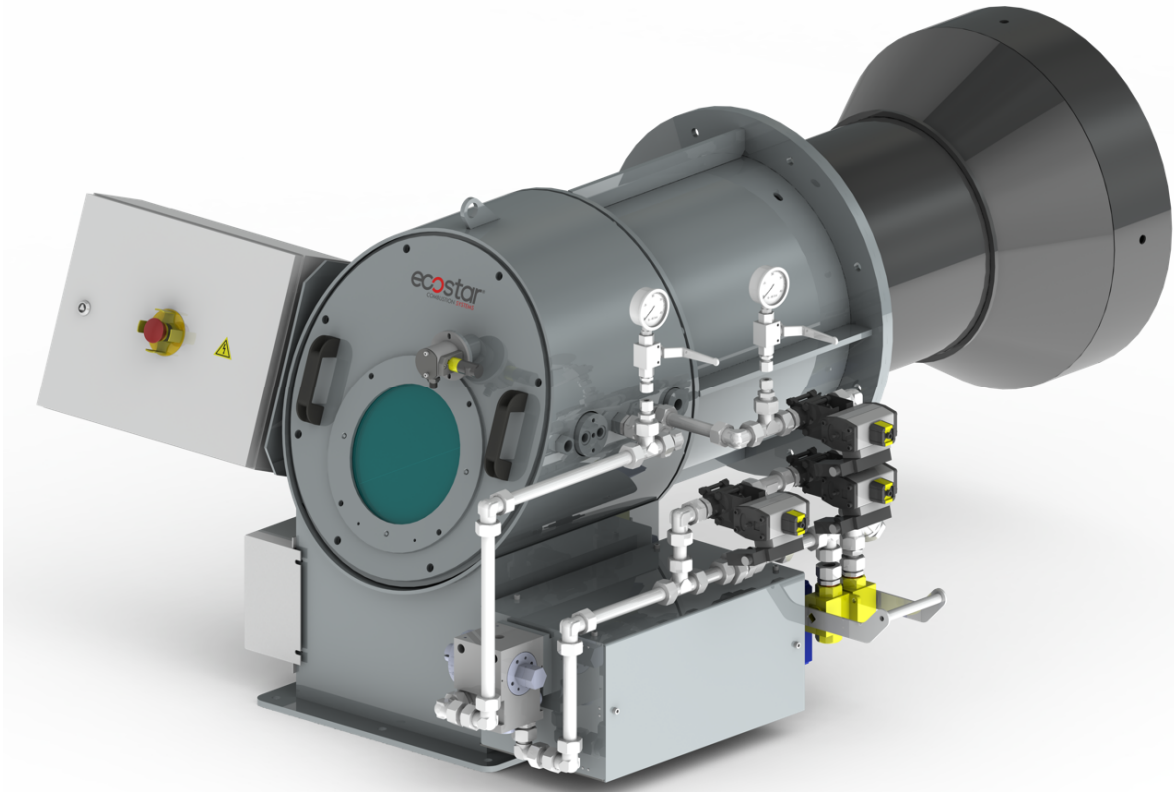

ECO 250
ECO 300
ECO 350
ECO 400
ECO 450
ECO 500
ECO 600
ECO 700
ECO 800
ECO 900



08.03.2024 Rev. 00

DEAR USER,

ECOSTAR ECO 250, ECO 300, ECO 350, ECO 400, ECO 450, ECO 500, ECO 600, ECO 700, ECO 800, ECO 900 Heavy Oil burners are prepared and manufactured according to the latest technical developments and safety rules. It is easy to use for our customers.

We recommend that you read this manual and safety warnings thoroughly before the use of the device in order to ensure safe, cost effective and environmental-friendly use.

If you encounter any issue that is not explained clearly in this manual or you could not understand, please contact with our service department.

We thank you for choosing ECOSTAR brand.

Ecostar Heavy Oil Burners are manufactured in accordance with TS EN 267 standards.

This Operating Manual is an integral part of the burner and must be maintained in a plastic dossier and hung at a clearly visible place in the burner room.



TERMO ISI SİSTEMLERİ SAN.VE TİC.A.Ş.

Esentepe Mah.Milangaz Cad. No:75 K:3

Kartal Monumento Plaza
Kartal/İSTANBUL/TÜRKİYE

Tel: +90 216 442 93 00

Fax: +90 216 370 45 03

www.ecostar.com.tr







e-mail:servis@ecostar.com.tr

CONTENTS

1.	WARNINGS	3
1.1.	Warning Symbols and Descriptions	3
1.2.	General Safety Rules	4
2.	TERMS OF WARRANTY	6
2.1.	Out of Warranty Conditions.....	6
3.	BURNER'S GENERAL FEATURES	7
3.1.	Purpose of Use and Work Limits of Burners.....	7
3.2.	Code Key.....	7
4.	TECHNICAL DATA	9
4.1.	Capacity Table.....	9
4.2.	Burner Dimensions	10
5.	INSTALLATION.....	12
5.1.	Burner Installation Picture	12
6.	COMMISSIONING	13
6.1.	General Controls.....	13
6.2.	Combustion Adjustment	14
6.2.1.	Pilot Ignition System	14
6.2.2.	PAL.....	16
6.3.	Photocell	19
6.4.	Nozzle	20
6.5.	Curves According To Fuel Consumption (Fuel Nozzles)	26
6.6.	Oil Adjustment Regulator.....	32
6.7.	Oil Burner Ring Line.....	33
6.8.	Servomotor Adjustment.....	34
6.9.	Emission Measurement.....	34
6.10.	Program Relay	35
7.	MAINTENANCE	37
7.1.	Weekly Maintenance	37
7.2.	Monthly Maintenance.....	37
7.3.	Seasonal Maintenance.....	38
8.	TROUBLESHOOTING	39
9.	PERIODICAL FLUE GAS MEASUREMENT REPORT.....	40
10.	AFTER SALES SERVICES.....	41
11.	NOTES	42

1. WARNINGS

1.1.Warning Symbols and Descriptions

Symbols	Symbol Descriptions
	Important information and useful hints.
	Warning of danger to life or property.
	Warning of electrical voltage.
	Product handling information.
	Electric motor direction of rotation
	Carry in an upright position. Fragile Item. Protect against water.

1.2. General Safety Rules

- All personnel engaged in installation, disassembly, commissioning, operation, control, maintenance and repair should have received the necessary training and fully read and understood this manual.
- No changes that might damage the safety of the burner unit must be made by persons and/or organizations on the burner unit.
- All operation, commissioning and installation works (except for burning adjustment) should be carried out when the burner is not operating and after disconnecting the power supply. Noncompliance with these rules may lead to serious bodily injuries and even death by electrical shocks or uncontrolled flame formation.
- Repairs concerned with safety elements should be carried out only by the manufacturing company.
- The device should never be used by children, mentally handicapped and inexperienced persons.
- Children must not be allowed to play with the device.
- Keep the device away from explosive and flammable materials.
- Device must intake air, ventilation and air discharge holes must not be closed.



Do not store any inflammable materials in boiler room.



Wear hearing protectors if there is noise in boiler room.



In case of fire or other emergency;

- Switch off the main switch
- Take appropriate actions



The burner installation must be carried out in accordance with the instructions. Vibration can damage the burner and its components.



Keep boiler doors closed while starting burner and during burner operation.



Check combustion values to be correct by using flue gas analyzer at the whole adjustment range between minimum, full load, and ignition load.



Use lifting device or belt for lifting fan motor, if necessary



During the first commissioning of the burner or in case of any revision carried out in the electrical system or motor cables by any reason, direction of the fan rotation must certainly be checked by the authorized technical service.



For products that have not been commissioned or started more than 6 months, before activating the servomotor;

In air dampers and oil regulators, servomotor and air damper connections must be checked to ensure that they are free running in spite of immobility and oil freezing.



BURNER ROOM

Install the burner in a suitable room/floor with minimum external air openings and sufficient to ensure perfect combustion, in compliance with current regulations.

Never obstruct air openings of the burner room, burner fan intake vents or air ducts in order to prevent:

- a. The build up of toxic / explosive gas mixtures in the burner room,
- b. Combustion with insufficient air, resulting in hazardous, anti-economical and polluting operation.

The burner must be always protected from rain, snow and frost to prevent corrosion and paint deformations.

Keep the burner room clean and free of solid volatile substances, which could be sucked into the fan and clog the internal burner or combustion head air ducts.

2. TERMS OF WARRANTY

Main and auxiliary equipment and all components used in Ecostar heavy oil burners are guaranteed for 1 year by TERMO ISI SİST. A.Ş starting from the date of commissioning under the maintenance, adjustment, operating conditions and relevant mechanic, chemical and thermal effects explained herein.



Please note that this warranty is only valid if the devices is commissioned and maintained by our authorized services.



Our company reserves the right to make any modifications on the product and all instructions thereof for improvement purposes.

2.1.Out of Warranty Conditions

- Any damage arising out of or in relation to customers' non-compliance to their responsibilities with regards to installation, commissioning, operation and maintenance,
- Any damage arising out of or in relation to commissioning, repairs and maintenance carried out by unauthorized services,
- Any damage that may occur during transportation or storage of the product,
- Not preserving the product in its original packaging until the installation stage,
- Incorrect and poor electrical connections, Failures due to incorrect voltage applications, frequent repetition of voltage fluctuations,
- Any damage that may occur as a result of incorrect fuel usage or, foreign substances in the fuel used or using of the product without any fuel,
- Any damage that may occur due to foreign particles entered into the product during installation and operation,
- Failures due to incorrect device selection,
- Any damage to unit due to natural disasters,
- Devices without any warranty certificates,
- Warranty Certificates without the stamp and signature of the authorized dealer or service,
- Devices with any falsification on the warranty certificate or without an original serial number.
- The risks during transportation of device under the responsibility of customer belong to the customer.
- Presence of misuse faults are indicated in the reports issued by authorized service stations or our authorized agent, dealer, representative or our factory in case of unavailability of authorized service stations.
- Customers may apply consumer protection arbitrator committee with regards to this report and request for an expert report.

3. BURNER'S GENERAL FEATURES

ECOSTAR Heavy Oil burners are designed to operate with oil at 2.5 – 20 Cst (mm²/s) viscosity, at rated capacity and pressure ranges and -15% to +10% nominal voltage.

3.1. Purpose of Use and Work Limits of Burners

- This product works at any load value equivalent to its max. capacity or covered by its capacity range;
 - In hot water and steam boilers,
 - In direct and indirect hot air generators,
 - Industrial appliances operating at temperature below 600 °C,
 - -15 °C...+60 °C ambient temperature range,
 - 1N 230 VAC/3N 380VAC /50 Hz feed voltage (-%15...+%10) values,
 - Max. 95% relative humidity,
 - In well-ventilated open and closed spaces compatible with protection class IP 40.



This device must never be operated with open flame!

3.2. Code Key

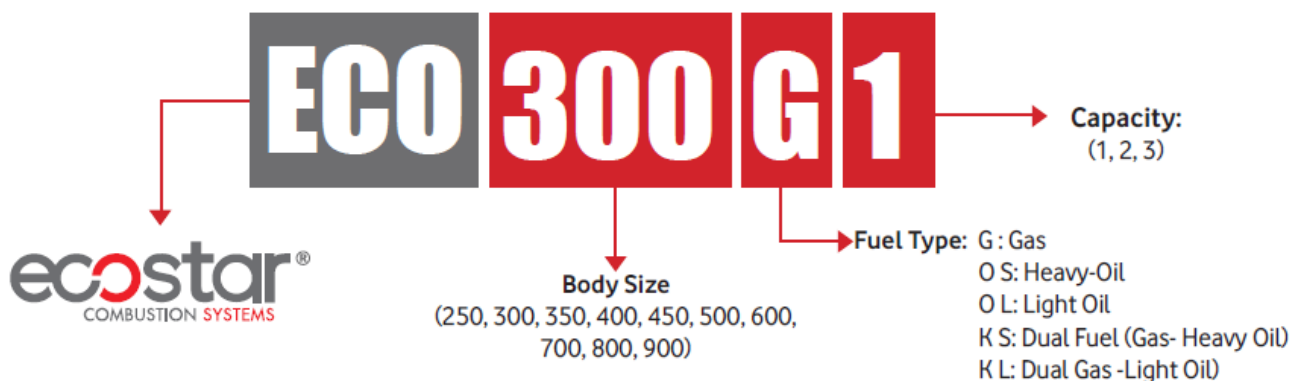

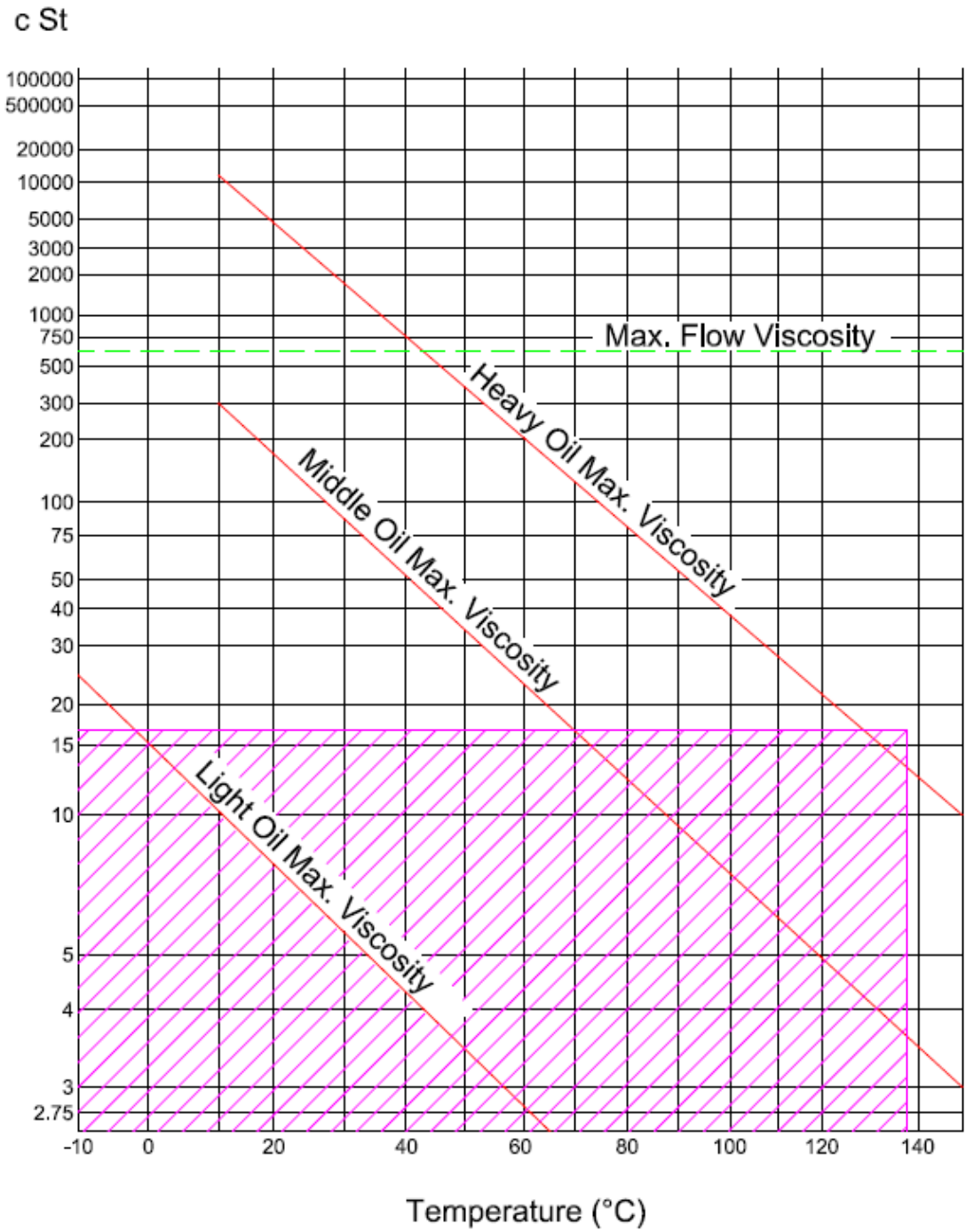

Temperature change of fuel used in ECOSTAR Heavy Oil burners dependent on viscosity



Operating Range

4. TECHNICAL DATA

4.1.Capacity Table

BURNER TYPE	CAPACITY		HEAVY OIL CONSUMPTION
	Max. MW	Max. kcal/h	Max. kg/h
ECO-250.1	1,9	1.600.000	165,8
ECO-250.2	2,6	2.250.000	233,2
ECO-300.1	3,4	2.900.000	300,5
ECO-300.2	4,2	3.600.000	373,1
ECO-350.1	5,0	4.300.000	445,6
ECO-350.2	6,2	5.300.000	549,2
ECO-350.3	7,3	6.300.000	652,8
ECO-400.1	8,1	7.000.000	725,4
ECO-400.2	8,8	7.600.000	787,6
ECO-400.3	9,7	8.300.000	860,1
ECO-450.1	11,5	9.900.000	1025,9
ECO-450.2	12,9	11.100.000	1150,3
ECO-450.3	14,5	12.450.000	1290,2
ECO-500.1	16,2	13.900.000	1440,4
ECO-500.2	17,8	15.300.000	1585,5
ECO-500.3	19,4	16.650.000	1725,4
ECO-600.1	20,8	17.900.000	1854,9
ECO-600.2	23,4	20.150.000	2088,1
ECO-600.3	25,0	21.500.000	2228,0
ECO-700.1	26,2	22.500.000	2331,6
ECO-700.2	27,3	23.500.000	2435,2
ECO-700.3	29,1	25.000.000	2590,7
ECO-800.1	32,1	27.600.000	2860,1
ECO-800.2	33,5	28.850.000	2989,6
ECO-800.3	35,2	30.250.000	3134,7
ECO-900.1	36,7	31.600.000	3274,6
ECO-900.2	39,2	33.750.000	3497,4
ECO-900.3	40,8	35.050.000	3632,1

H_u Heavy Oil (S) = 9650 Kcal/kg

Mechanical Modulating Burner-Modulation Ratio: Liquid Fuel 3:1

4.2. Burner Dimensions

➤ Fuel Oil Asphalt Plant

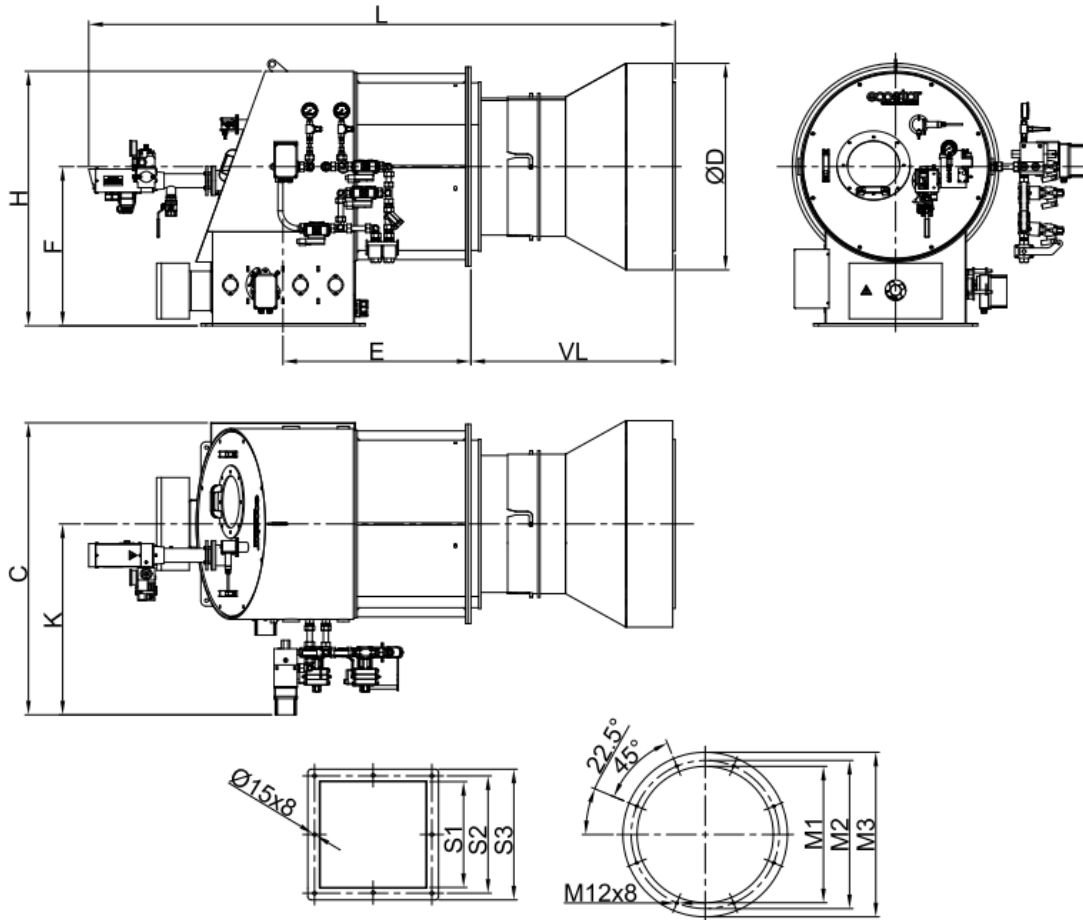

	Ø D	L	E	H	F	C	K	S1	S2	S3	Ø M1	Ø M2	Ø M3	VL
ECO 250 OS 1	-	1850	650	875	500	700	325	250	300	340	Ø380	Ø430	Ø500	570
ECO 250 OS 2	-	1850	650	875	500	700	325	250	300	340	Ø380	Ø430	Ø500	570
ECO 300 OS 1	-	1850	650	875	500	700	325	300	350	385	Ø380	Ø430	Ø500	570
ECO 300 OS 2	-	1850	650	875	500	700	325	300	350	385	Ø380	Ø430	Ø500	570
ECO 350 OS 1	Ø520	1900	675	900	550	740	350	350	410	450	Ø430	Ø480	Ø550	670
ECO 350 OS 2	Ø520	1900	675	900	550	740	350	350	410	450	Ø430	Ø480	Ø550	670
ECO 350 OS 3	Ø520	1900	675	900	550	740	350	350	410	450	Ø430	Ø480	Ø550	670
ECO 400 OS 1	Ø590	1900	675	920	600	900	500	400	450	510	Ø480	Ø530	Ø600	670
ECO 400 OS 2	Ø590	1900	675	920	600	900	500	400	450	510	Ø480	Ø530	Ø600	670
ECO 400 OS 3	Ø590	1900	675	920	600	900	500	400	450	510	Ø480	Ø530	Ø600	670
ECO 450 OS 1	Ø665	1950	675	960	640	1000	500	450	500	556	Ø580	Ø630	Ø700	750
ECO 450 OS 2	Ø665	1950	675	960	640	1000	500	450	500	556	Ø580	Ø630	Ø700	750
ECO 450 OS 3	Ø665	1950	675	960	640	1000	500	450	500	556	Ø580	Ø630	Ø700	750
ECO 500 OS 1	Ø740	2500	760	1100	690	1000	500	500	550	608	Ø660	Ø710	Ø800	870
ECO 500 OS 2	Ø740	2500	760	1100	690	1000	500	500	550	608	Ø660	Ø710	Ø800	870
ECO 500 OS 3	Ø740	2500	760	1100	690	1000	500	500	550	608	Ø660	Ø710	Ø800	870
ECO 600 OS 1	Ø890	2550	810	1100	690	1000	500	600	660	708	Ø740	Ø792	Ø860	870
ECO 600 OS 2	Ø890	2550	810	1100	690	1000	500	600	660	708	Ø740	Ø792	Ø860	870
ECO 600 OS 3	Ø890	2550	810	1100	690	1000	500	600	660	708	Ø740	Ø792	Ø860	870
ECO 700 OS 1														
ECO 700 OS 2														
ECO 700 OS 3														
ECO 800 OS 1														
ECO 800 OS 2														
ECO 800 OS 3														
ECO 900 OS 1														
ECO 900 OS 2														
ECO 900 OS 3														

Contact The Sales Department

Please Contact The Sales Unit For Special VL Sizes.

➤ Fuel Oil Steam Boiler

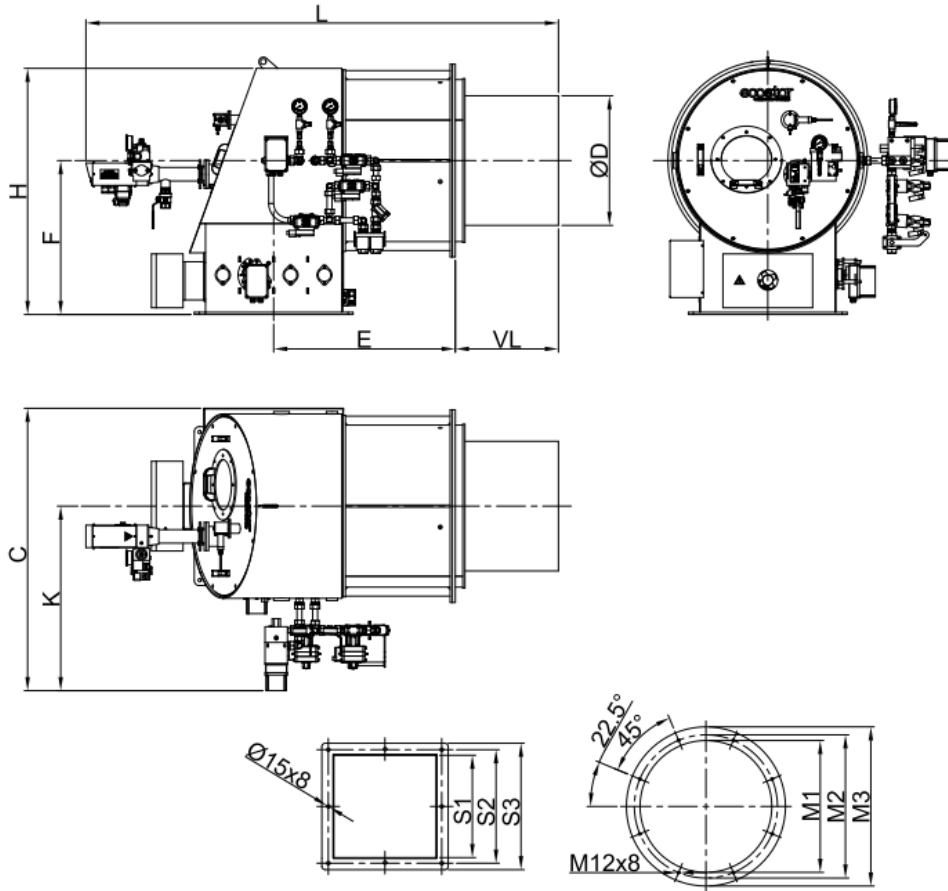

	Ø D	L	E	H	F	C	K	S1	S2	S3	Ø M1	Ø M2	Ø M3	VL
ECO 250 OS 1	Ø219	1600	650	875	500	1100	725	250	300	340	Ø330	Ø380	Ø450	320
ECO 250 OS 2	Ø246	1600	650	875	500	1100	725	250	300	340	Ø330	Ø380	Ø450	320
ECO 300 OS 1	Ø259	1600	650	875	500	1100	725	300	350	385	Ø380	Ø430	Ø500	320
ECO 300 OS 2	Ø295	1600	650	875	500	1100	725	300	350	385	Ø380	Ø430	Ø500	320
ECO 350 OS 1	Ø323	1550	675	900	550	1140	750	350	410	450	Ø430	Ø480	Ø550	320
ECO 350 OS 2	Ø350	1550	675	900	550	1140	750	350	410	450	Ø430	Ø480	Ø550	320
ECO 350 OS 3	Ø365	1550	675	900	550	1140	750	350	410	450	Ø430	Ø480	Ø550	320
ECO 400 OS 1	Ø393	1600	675	920	600	1300	900	400	450	510	Ø480	Ø530	Ø600	370
ECO 400 OS 2	Ø401	1600	675	920	600	1300	900	400	450	510	Ø480	Ø530	Ø600	370
ECO 400 OS 3	Ø431	1600	675	920	600	1300	900	400	450	510	Ø480	Ø530	Ø600	370
ECO 450 OS 1	Ø450	1550	675	960	640	1400	900	450	500	556	Ø580	Ø630	Ø700	350
ECO 450 OS 2	Ø485	1550	675	960	640	1400	900	450	500	556	Ø580	Ø630	Ø700	350
ECO 450 OS 3	Ø499	1550	675	960	640	1400	900	450	500	556	Ø580	Ø630	Ø700	350
ECO 500 OS1	Ø542	2105	760	1100	690	1450	950	500	550	608	Ø660	Ø710	Ø800	475
ECO 500 OS 2	Ø556	2105	760	1100	690	1450	950	500	550	608	Ø660	Ø710	Ø800	475
ECO 500 OS 3	Ø568	2105	760	1100	690	1450	950	500	550	608	Ø660	Ø710	Ø800	475
ECO 600 OS 1	Ø599	2155	810	1100	690	1450	950	600	660	708	Ø740	Ø792	Ø860	475
ECO 600 OS 2	Ø619	2155	810	1100	690	1450	950	600	660	708	Ø740	Ø792	Ø860	475
ECO 600 OS 3	Ø630	2155	810	1100	690	1450	950	600	660	708	Ø740	Ø792	Ø860	475
ECO 700 OS 1														
ECO 700 OS 2														
ECO 700 OS 3														
ECO 800 OS 1														
ECO 800 OS 2														
ECO 800 OS 3														
ECO 900 OS 1														
ECO 900 OS 2														
ECO 900 OS 3														

Contact The Sales Department

Please Contact The Sales Unit For Special VL Sizes.

5. INSTALLATION

5.1. Burner Installation Picture

Installation on the Boiler

- In the installation of the burner, please only use the installation materials supplied with the burner.
- Make sure that there are no gaps between the flange and boiler cover and ensure a full sealing by a gasket.

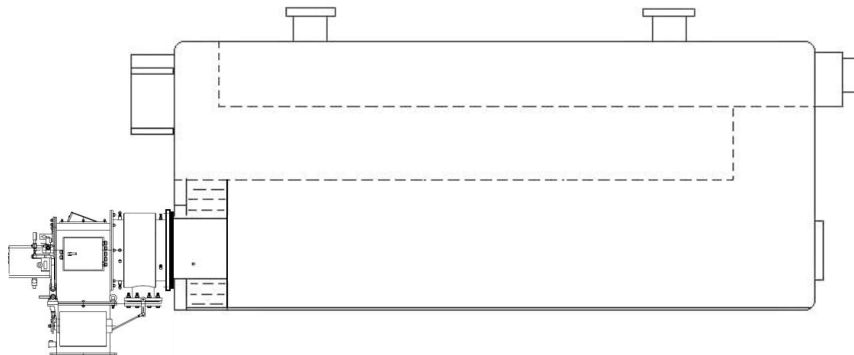

Make sure that, when installing burner at tree pass boilers, the end point of flame pipe should be on the same plane with the cover insulation material.

Asphalt plant application

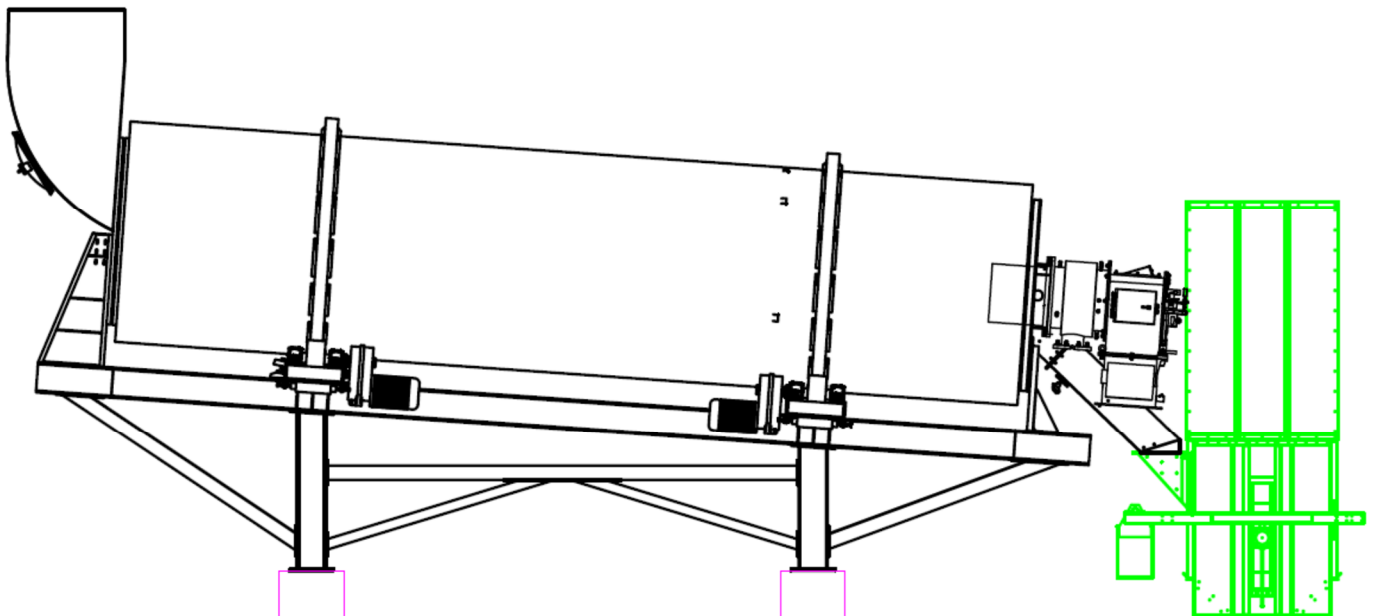

6. COMMISSIONING

6.1. General Controls



Make sure to perform the following controls before commissioning the burner.

- Installation of the burner to the boiler is checked.
- Check the fuel line (are the pipe diameters and the pipe installation correct?).
- Check energy input cables and voltages.
- Check the fuel nozzles according to the boiler capacity.
- Prior to operating the burner, control the boiler water level.
- Make sure water circulation system is turned on, and steam boiler and water feed pumps and boiler inlet - outlets are open.
- Is there electricity current?
- Is there sufficient air in boiler room

Commissioning order

- Open the main gas valves.
- Open operating switch on the burner panel.
- Turn modulating control switch to automatic.
- Check the temperature and pressure set values from the modulating control unit.
- Burner fan motor will be activated.
- Check if the gas pressure from the inlet manometer is 30 bars.
- Air Dampers will open during pre-purge and ignition will take place once dampers are in start position.
- 3 sec. later, the F.O. operating valve will be opened and combustion will occur.
- Flame control system will start to flame control.
- In modulating burner, the burner goes into max. capacity according to the signal from the modulating control unit.
- When the boiler water temperature or steam pressure increase, the modulating control unit will cause burner to run with min. capacity.
- If the boiler water temperature or steam pressure increases despite the operation of burner with min. capacity, the modulating control unit will stop the burner.

6.2. Combustion Adjustment

6.2.1. Pilot Ignition System

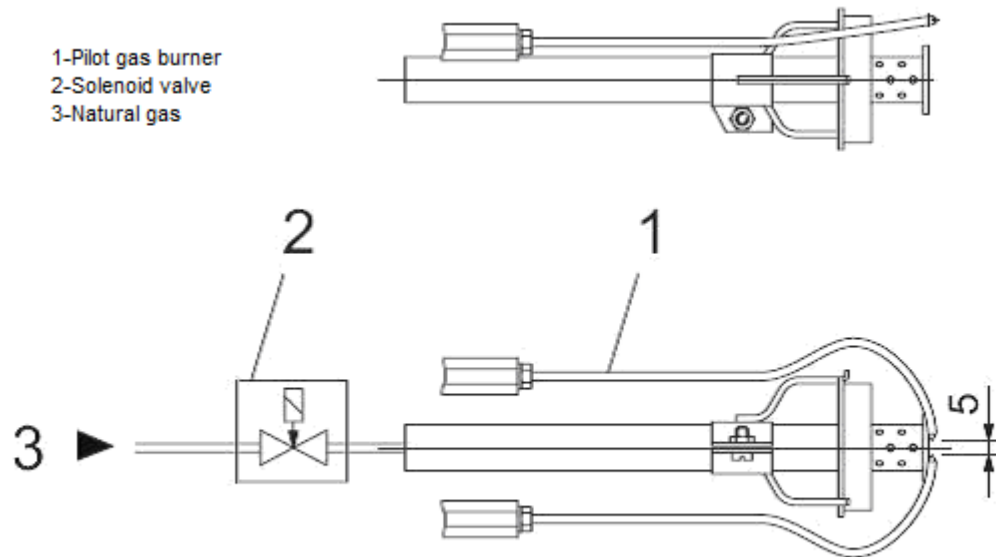

**Pilot gas burner inlet pressure $P_{max}=150-200$ mbar.
Operation should be set to 80-100mbar.**

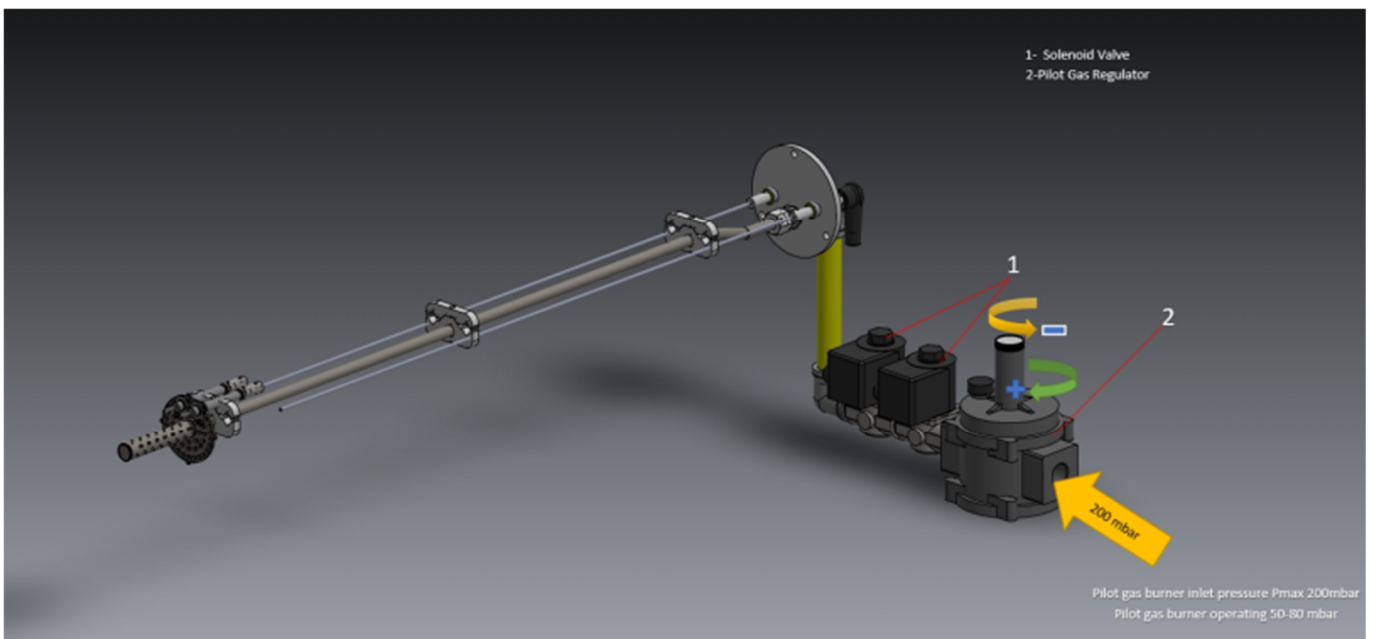
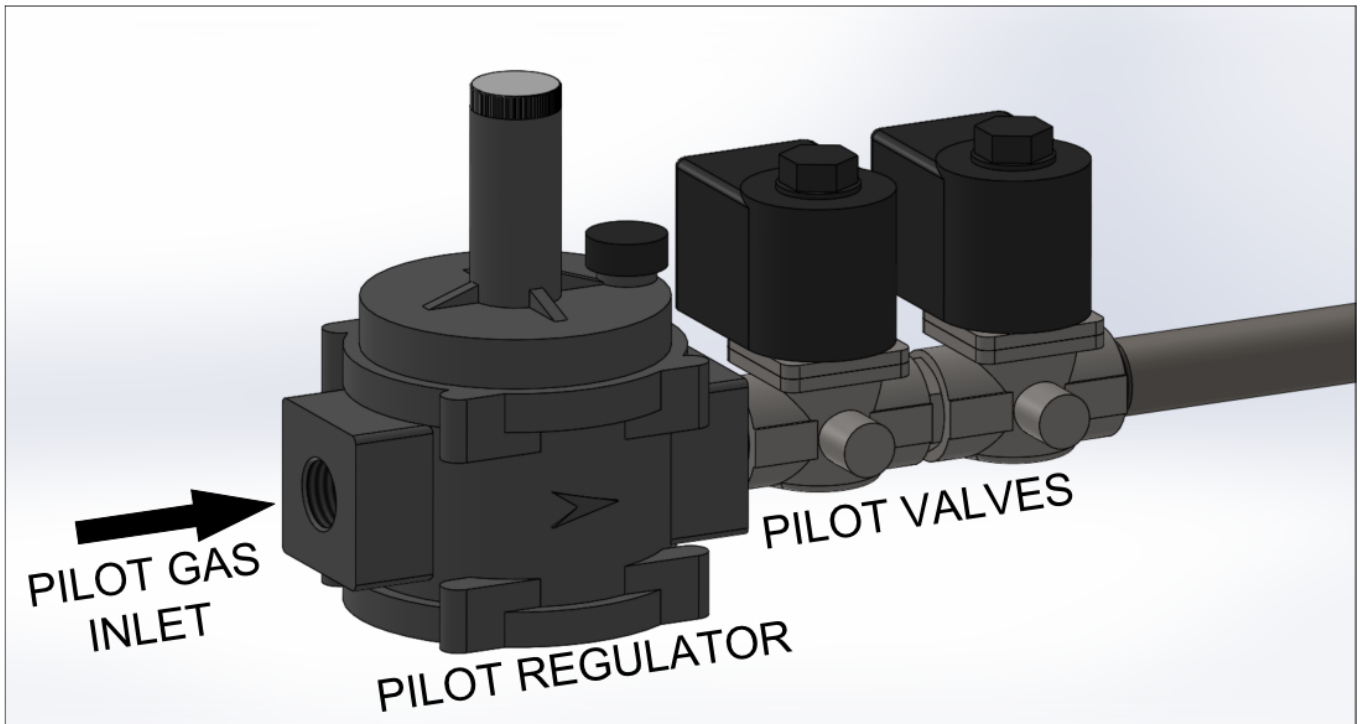

6.2.2.PAL

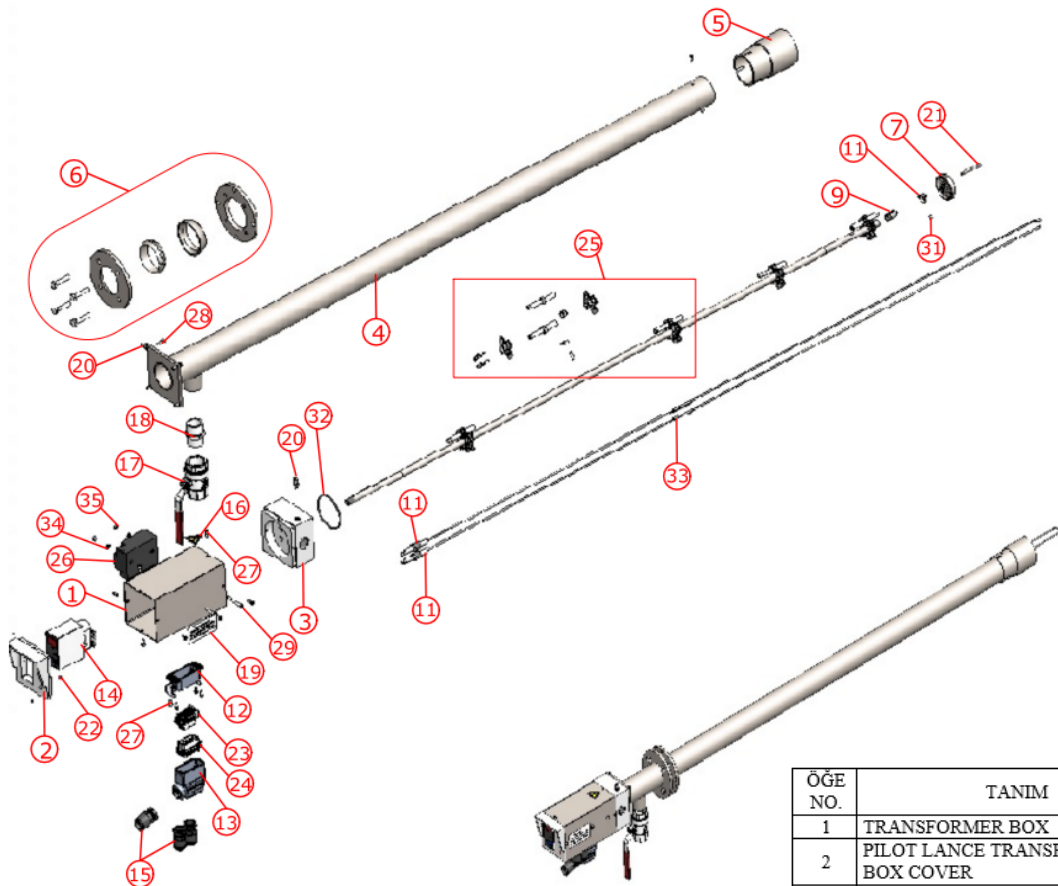

Gas inlet pressure:35mbar
Air pressure:17mbar
Qmax:4,5m³/h
Flame length:400mm

ÖGE NO.	TANIM
1	TRANSFORMER BOX
2	PILOT LANCE TRANSFORMER BOX COVER
3	PILOT LANCE BODY
4	PILOT LANCE OUTER PIPE
5	FLAME STABILIZER
6	PILOT LANCE CONNECTING FLANGE
7	TURBULATOR
8	GAS PIPE INNER
9	GAS NOZZLE
10	TURBULATOR CENTERING PART
11	IGNITION ELECTRODE
12	MACHINE TYPE SOCKET
13	SOCKET BODY
14	FLAME MONITOR
15	SLEEVE
16	LABEL HIGH VOLTAGE
17	NATURAL GAS BALL VALVE
18	CASTING NIPPLE
19	LABEL
20	PURGER
21	IGNITION ARC SHAFT
22	RED LAMP
23	SOCKET
24	RECEIPT
25	PILOT LANCE CENTERING TRANSFORMER
26	TRANSFORMER
27	BOLT
28	BOLT
29	BOLT
30	SET SCREW
31	SET SCREW
32	O-RING
33	SPLIT PIN
34	WASHER
35	NUT

Flame Monitor



03U1 Structure of the flame monitor

-
- Electronic flame monitoring circuit,
- A relay with bipolar-bidirectional free contact output
- A bargraph or dotmatrix led set, displaying flame existence or level
- Buttons to set the delay time of the flame relay
- A display that displays “ON” when the flame is detected and “OFF” when the flame goes out
- The outer box is made of heat resistant plastic.

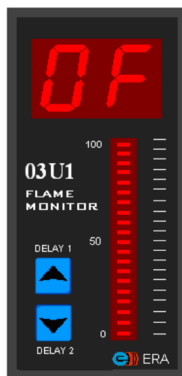

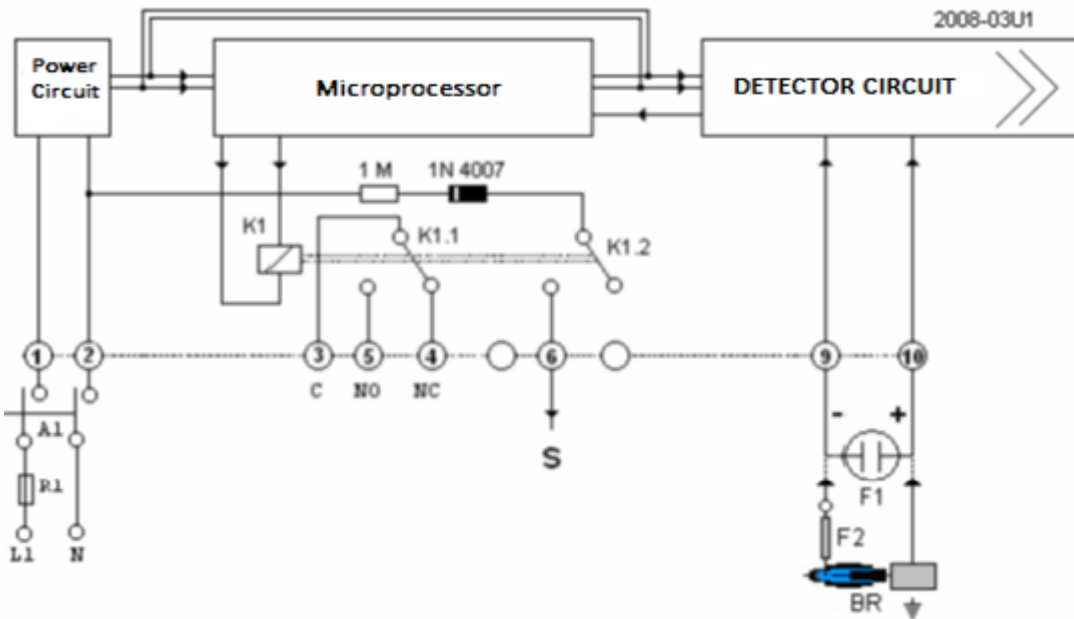

03A1 Structure of the flame monitor

- Electronic flame monitoring circuit,
- A relay with bipolar-bidirectional free contact output
- A operation lamp that is integrated to the electronic circuit which operates according to the flame's existence and strength,
- Buttons to set the delay time of the flame relay
- A display that displays "ON" when the flame is detected and "OFF" when the flame goes out
- The outer box is made of heat resistant plastic.
-
-



The controller device must never be opened or modified!

- The flame monitor must be installed and run by authorized staff only.
- The power supply must be turned off prior to removing the device from its socket
- Connection terminals must be checked after installation of cables
- If any problem occurs with the device, our technical staff must be contacted before intervening.



6.3. Photocell

Check the photocell weekly. Clean the dust or fume stains on the glass of photocell by a dry cloth.

➤ **QRB1**

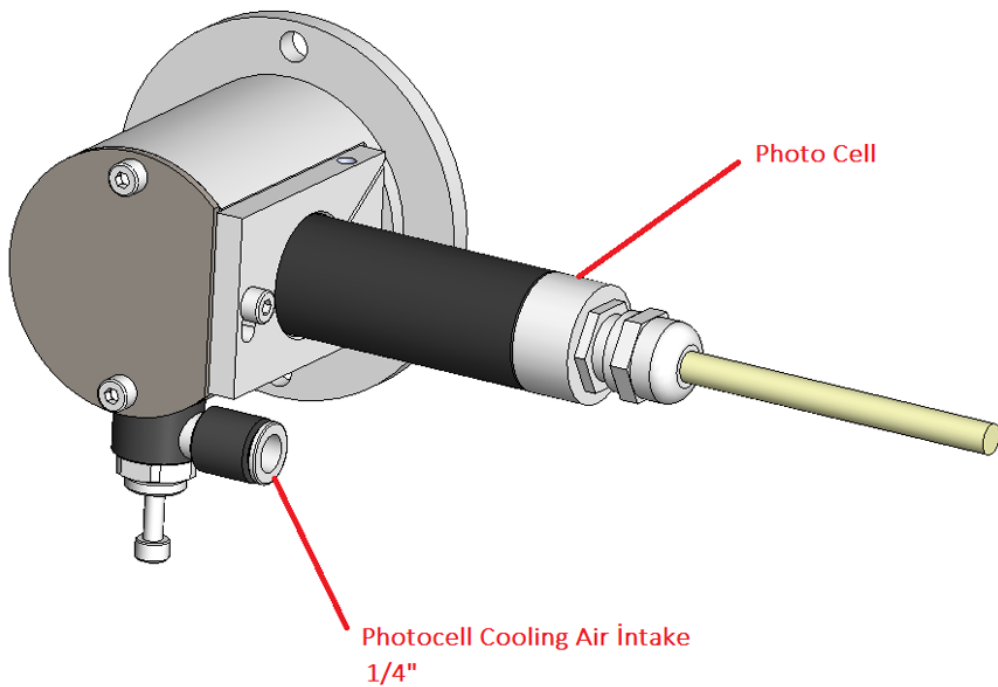
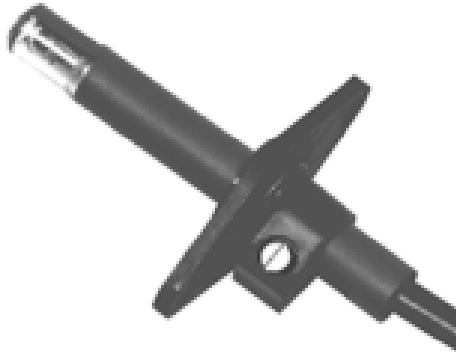

6.4. Nozzle

➤ HA-D Nozzle

32-HA-D is a needle closed lance with return line. Shut down needle (4) make press to nozzle plate (6) through a spiral on pushing piston. Shut down needle is opened by pneumatic way.

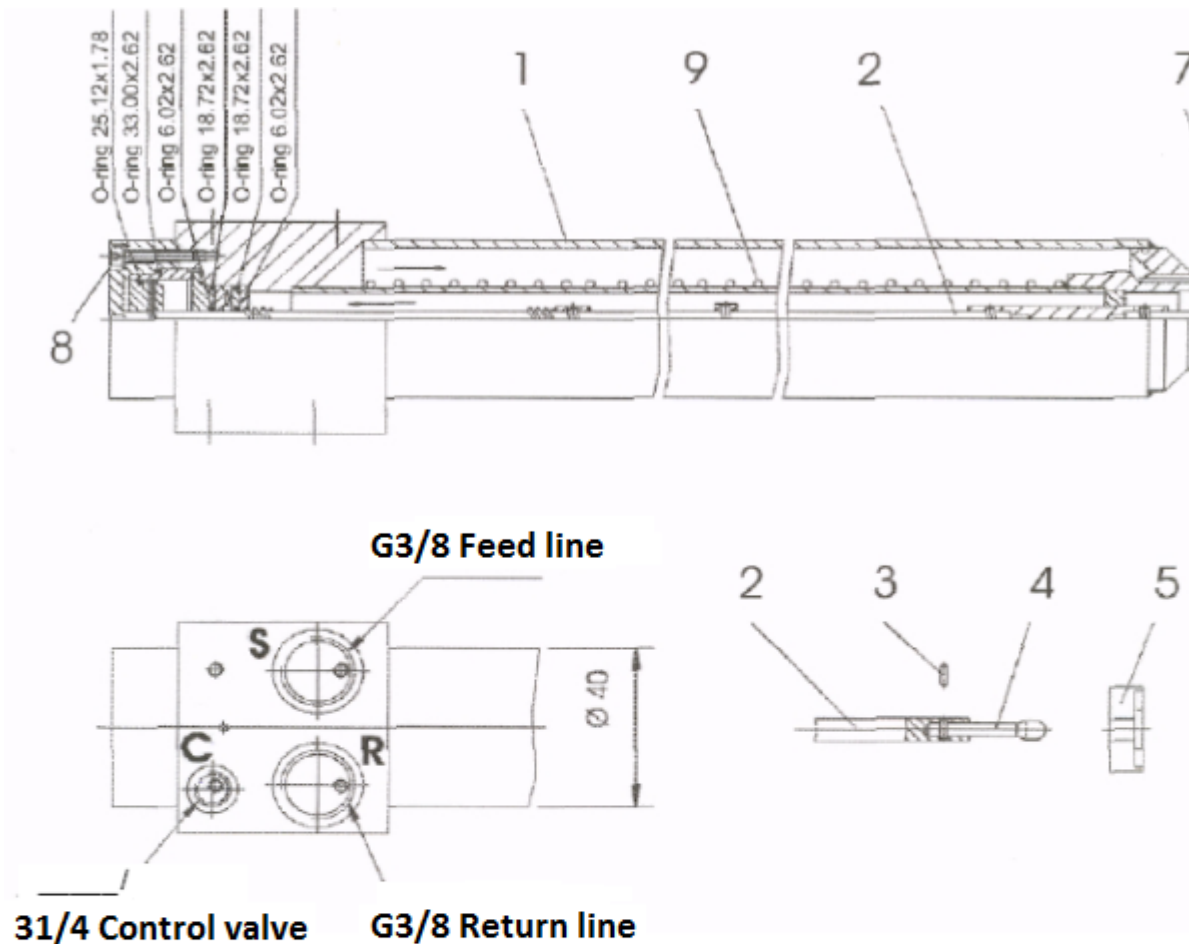

- | | | | |
|---|------------------|---|--------------|
| 1 | 32 HA-D | 6 | Nozzle plate |
| 2 | Nozzle rod | 7 | Collar nut |
| 3 | Pin | 8 | Screw |
| 4 | Shut-off needle | 9 | Resistance |
| 5 | Turbulence plate | | |

installation of shut-off needle and plates

.Loosen the screws(8) and pull out the nozzle rod(2) backwards

.Insert shut-off needle(4) and pin(3)

.After inserting the rod, check if the needle head is inserted in the needle guide and turbulence plate

➤ **HA-D Nozzle Hydraulic Diagram**

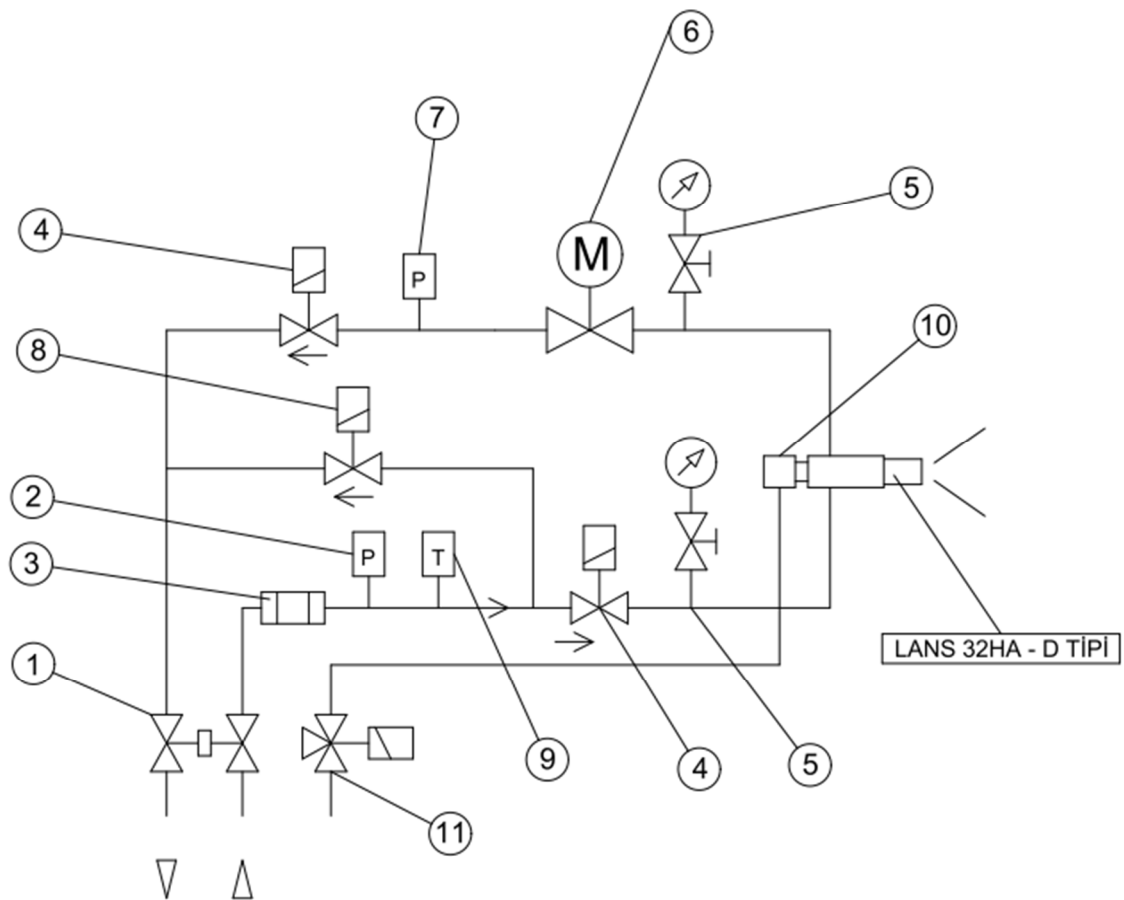

- 1- Double Ball Valve
- 2- Pressure Switch Min. (Optional)
- 3- Filter
- 4- Selenoid Valve
- 5- Manometer and Tap
- 6- 3/4" Oil Adjustment Valve and Servomotor
- 7- Pressure Switch Max. (Optional)
- 8- Selenoid Valve
- 9- Thermostat
- 10- Pneumatic Air Inlet
- 11- 3/2 Way Valve (Compressor Air)

➤ SK Nozzle

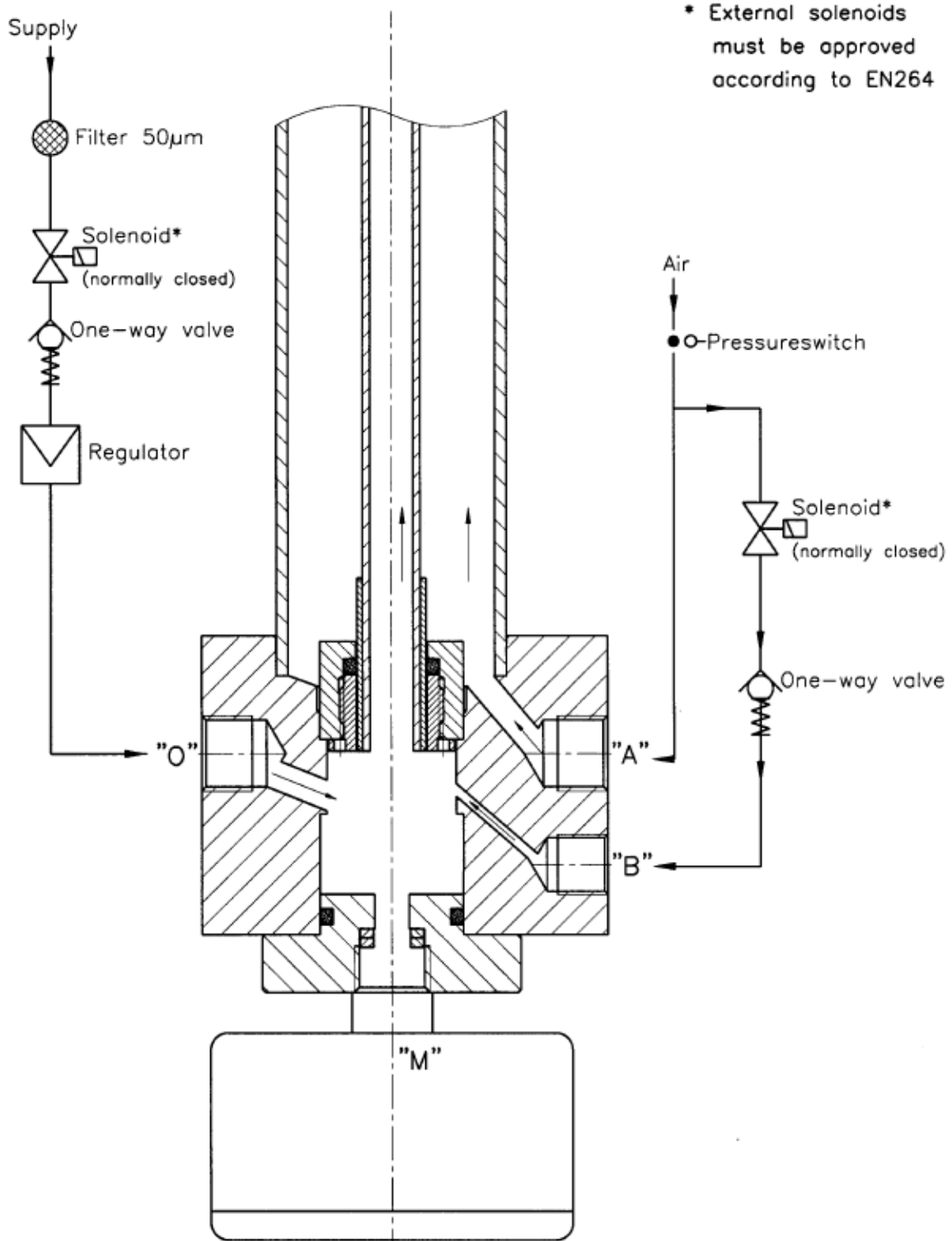

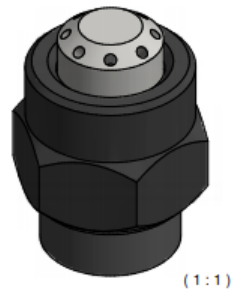
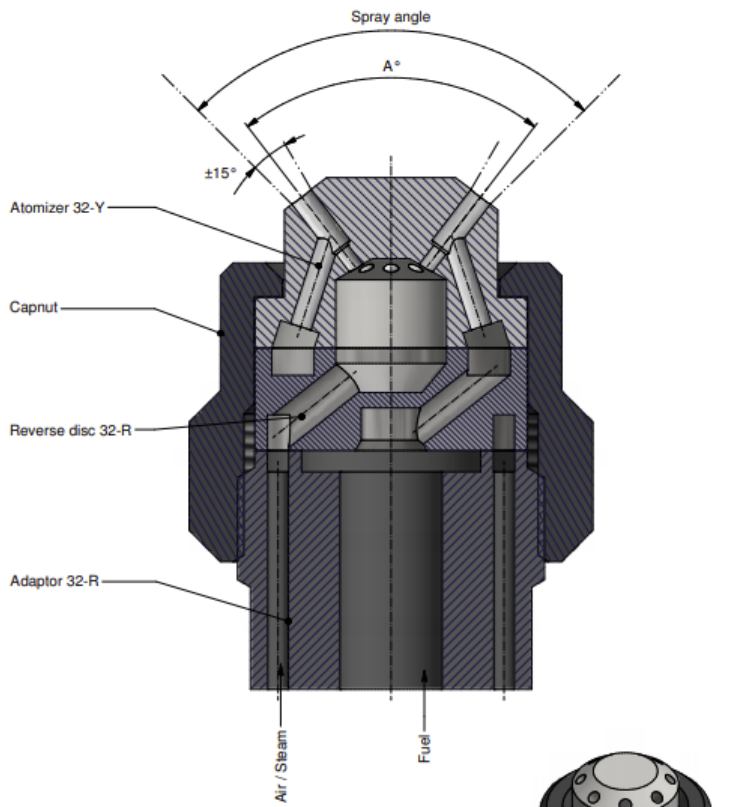
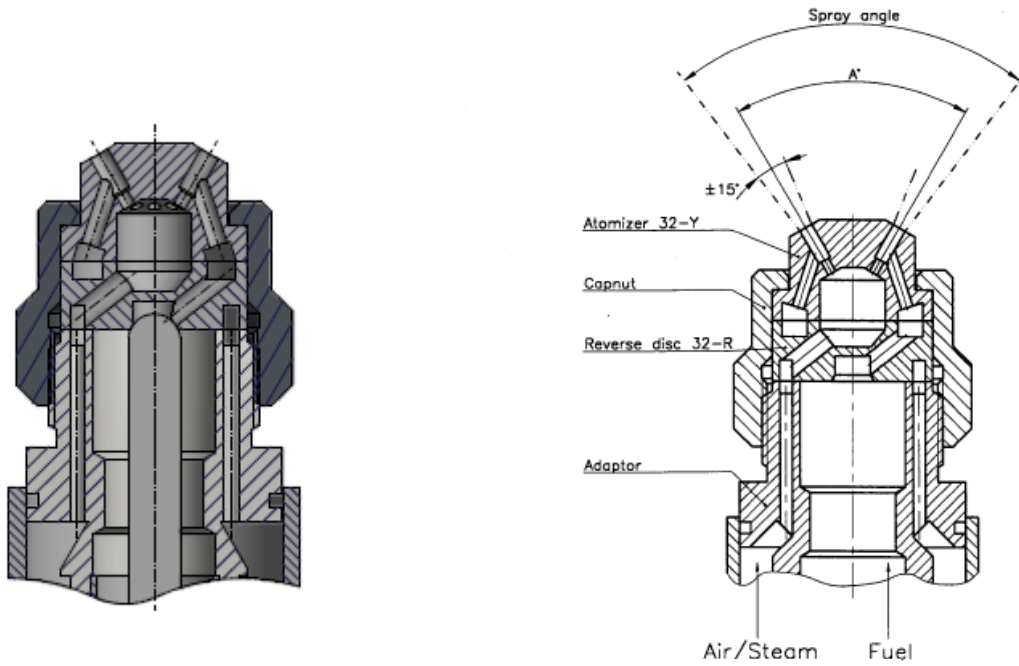

(1:1)

➤ SK Type Nozzle Hydraulic Diagram

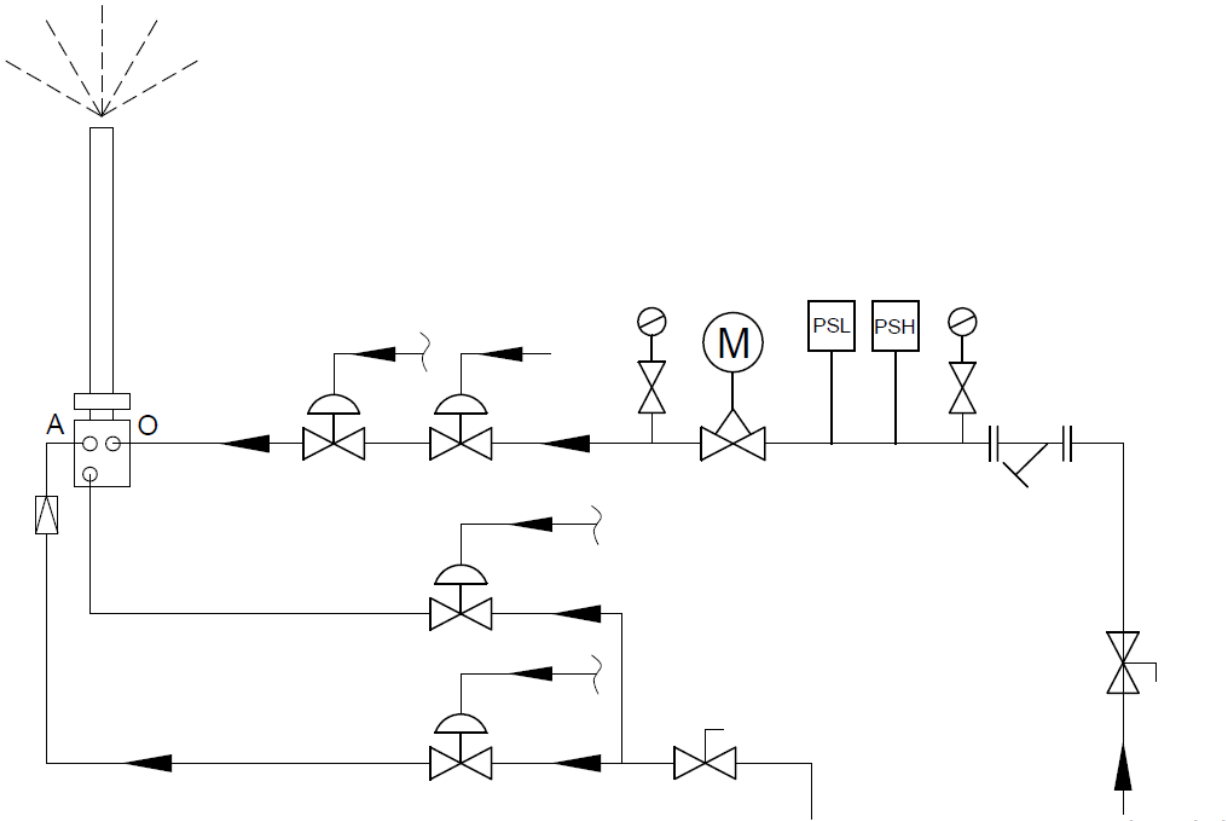

➤ H Type Nozzle Hydraulic Diagram

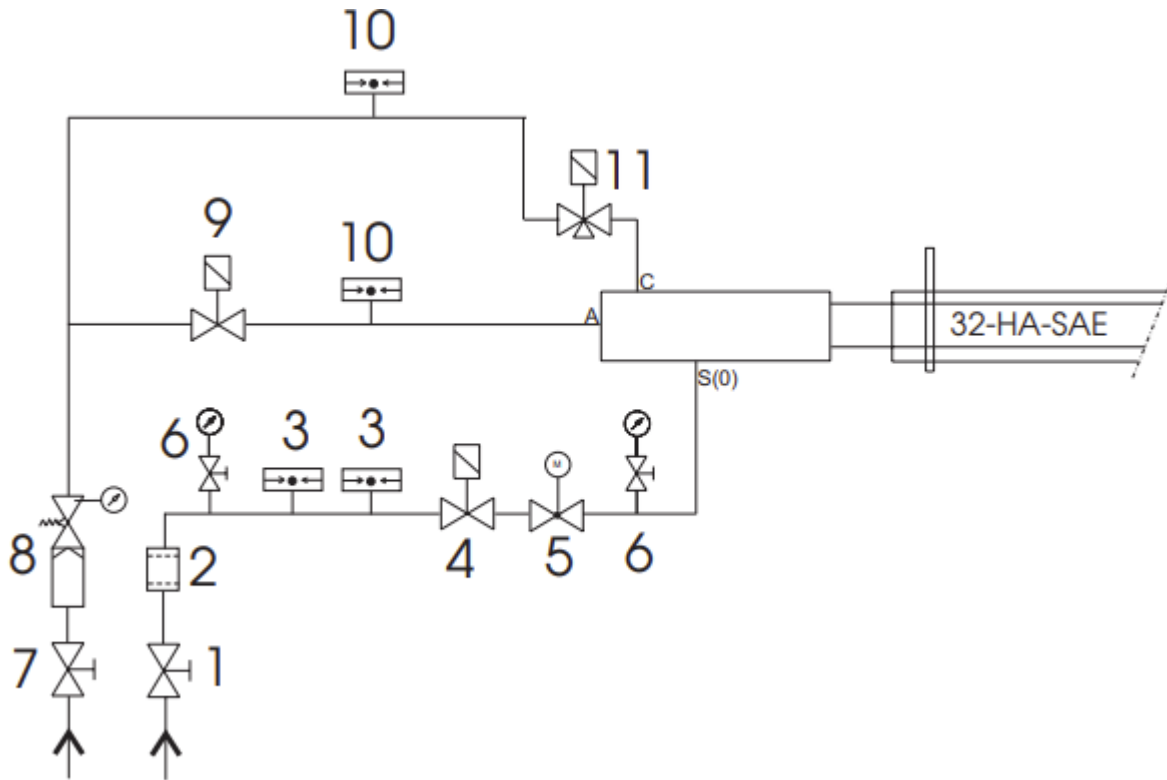

6.5. Curves According To Fuel Consumption (Fuel Nozzles)

➤ ECO 250.1 & ECO 350.2

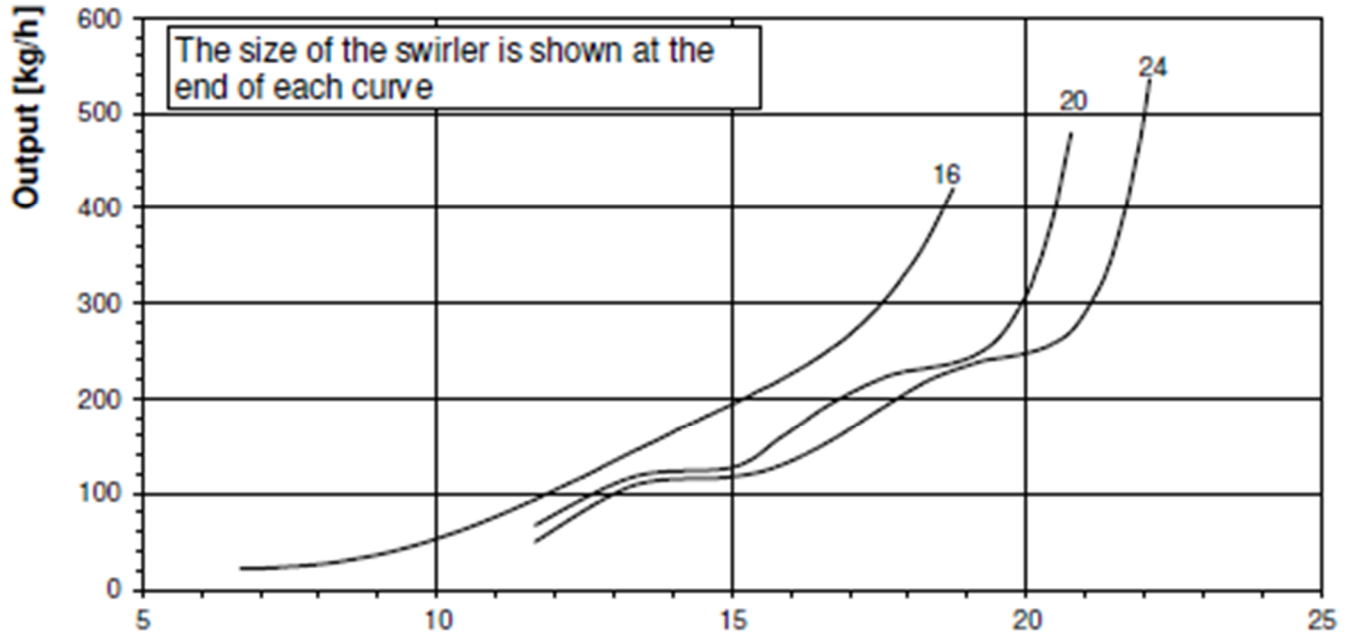

➤ ECO 350.3 & ECO 400.1

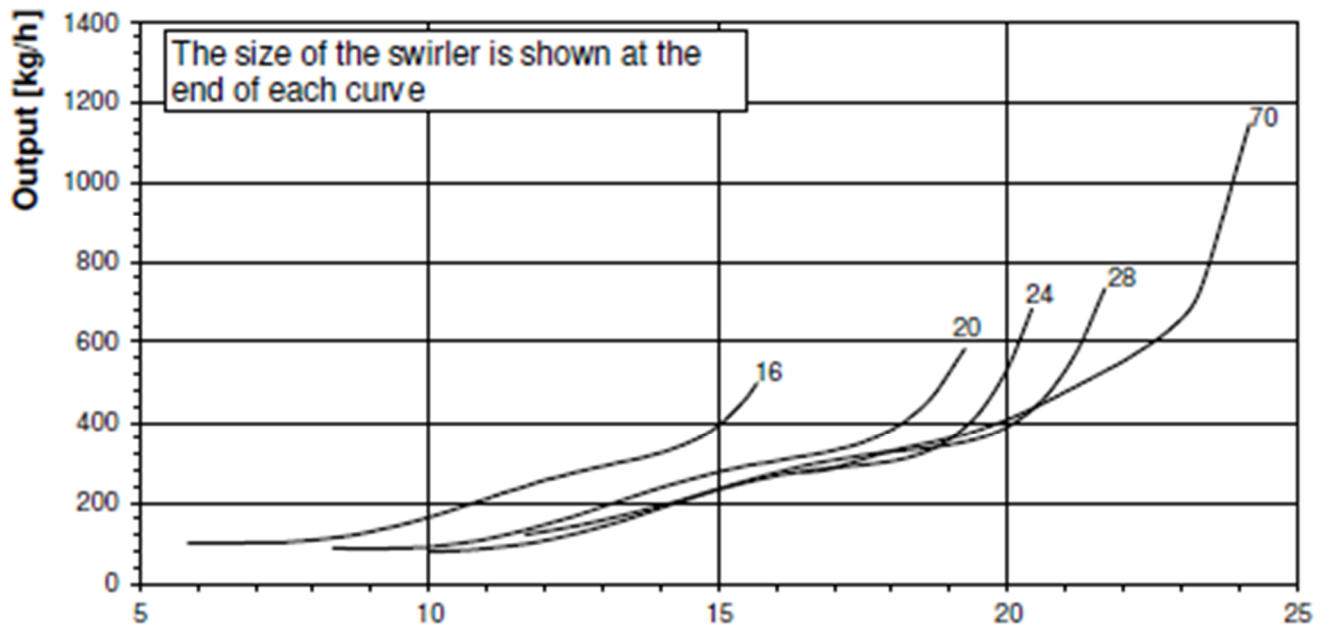

Pump Operating Pressure 25 Bar

➤ ECO 400.2 & ECO 400.3 & ECO 450.1

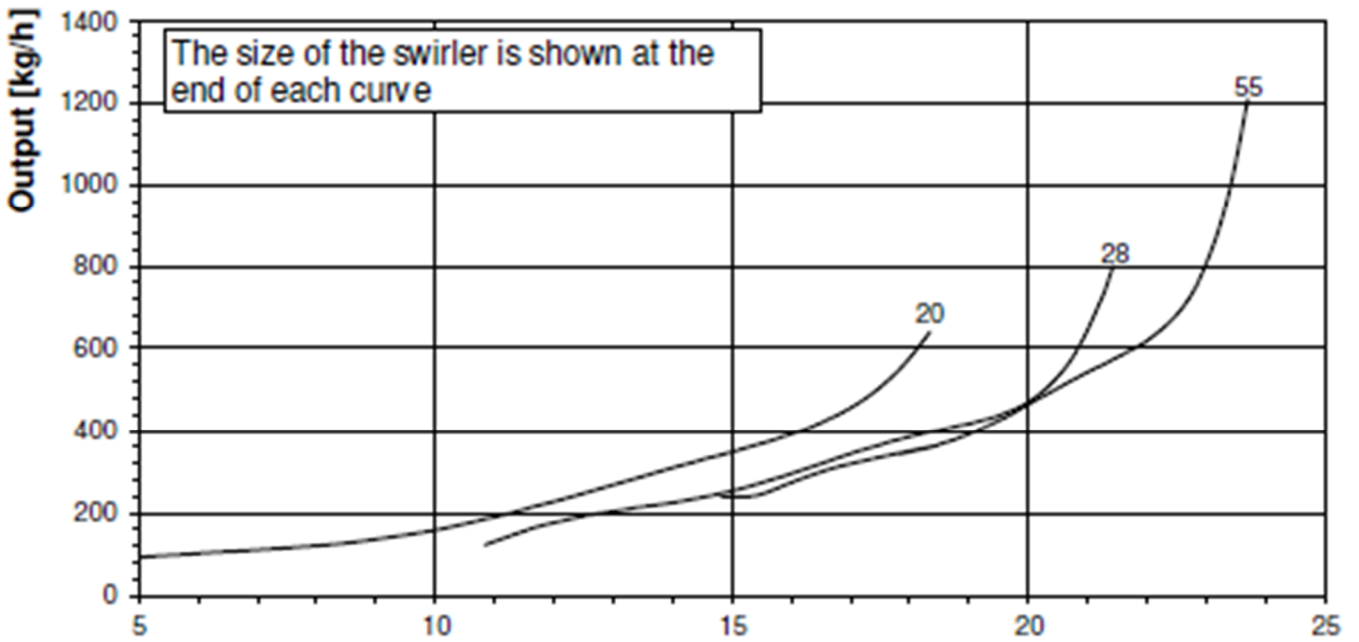

➤ ECO 450.2 & ECO 450.3

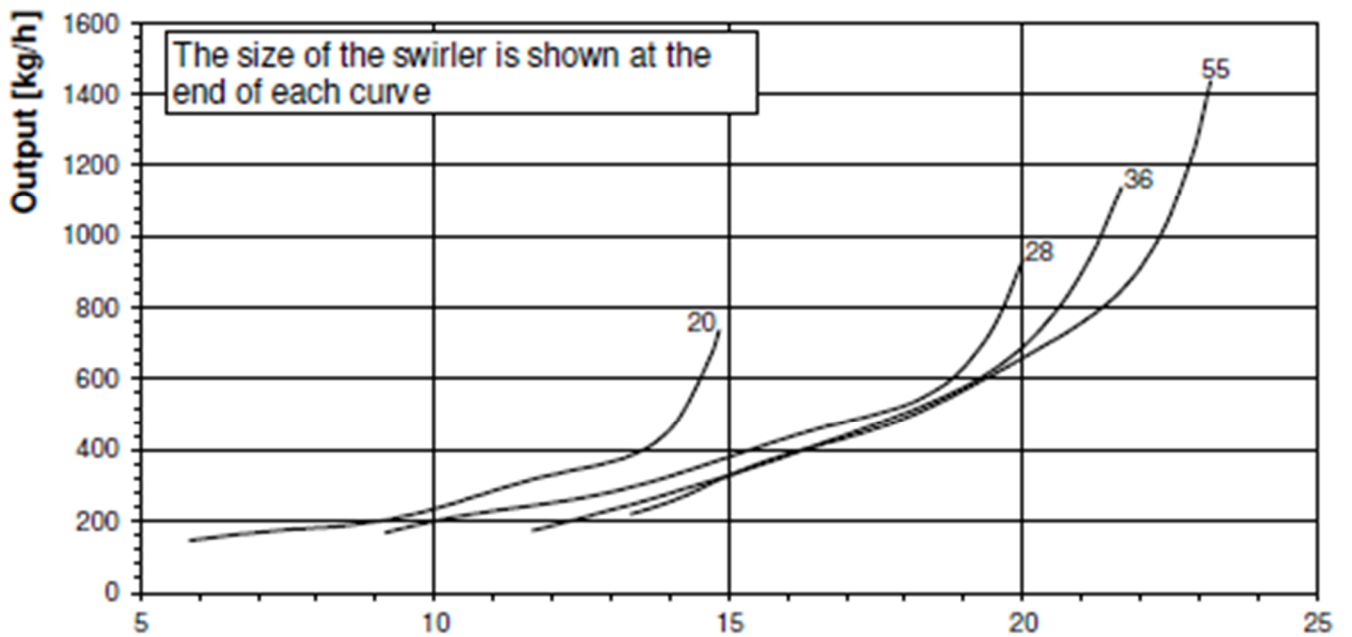

Pump Operating Pressure 25 Bar

➤ ECO 500.1 & ECO 500.2

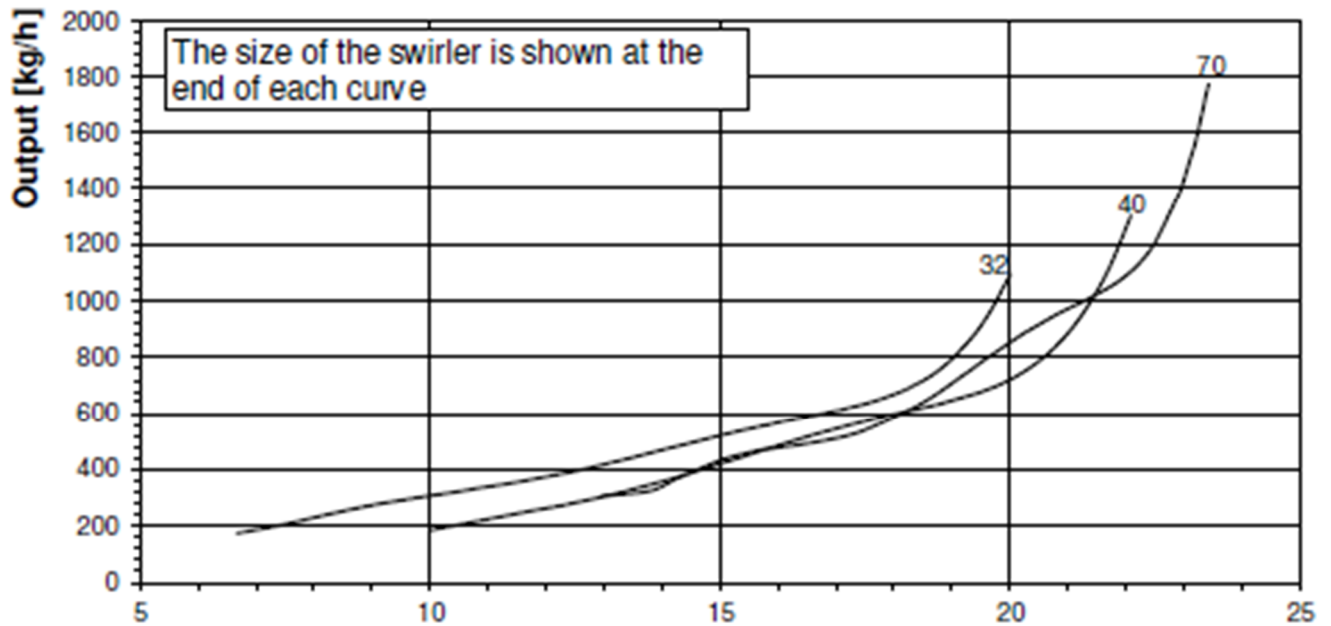

➤ ECO 500.3 & ECO 600.1

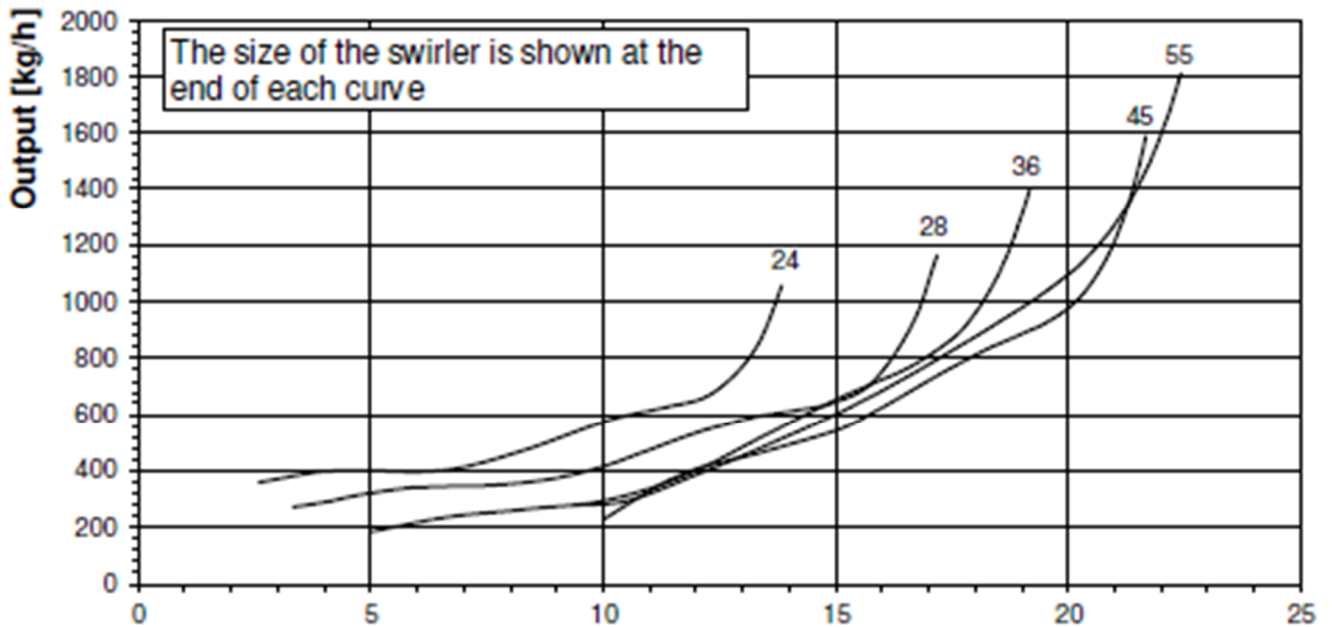

Pump Operating Pressure 25 Bar

➤ ECO 600.2

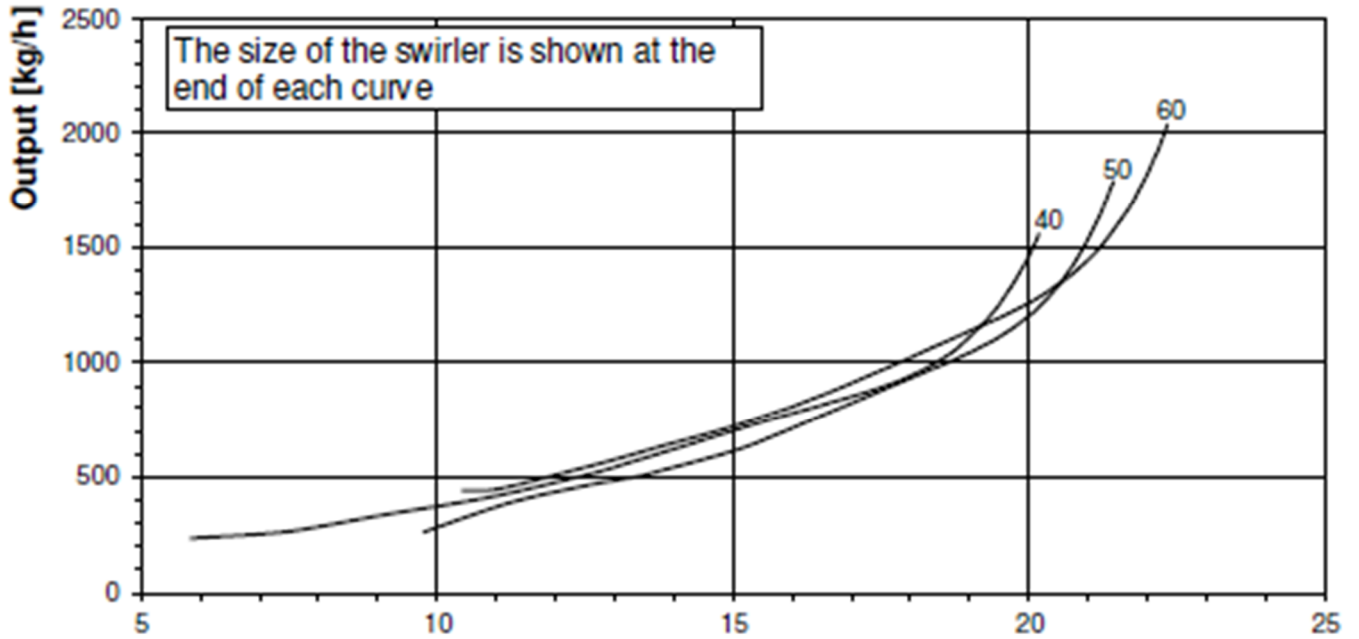

➤ ECO 600.3 & ECO 700.1 & ECO 700.2 & ECO 700.3

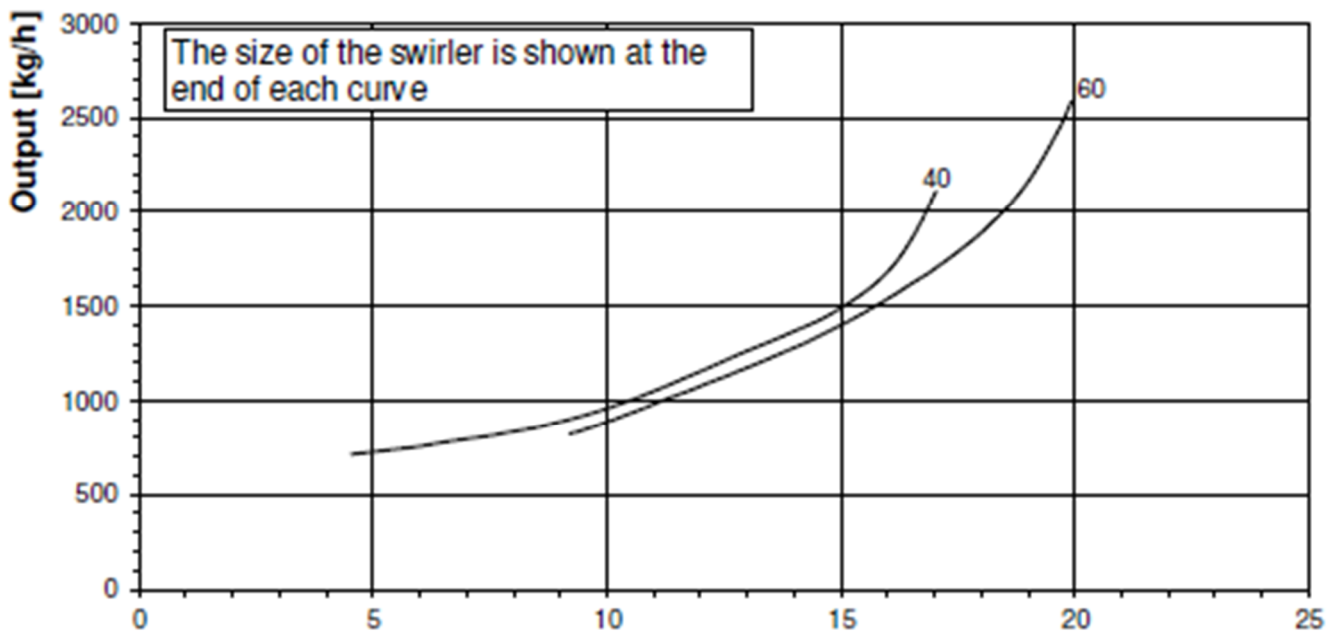

Pump Operating Pressure 25 Bar

➤ **ECO 800.1 & ECO 800.2**

Atomizer 32-Y-A°-14-7 with reverse disc

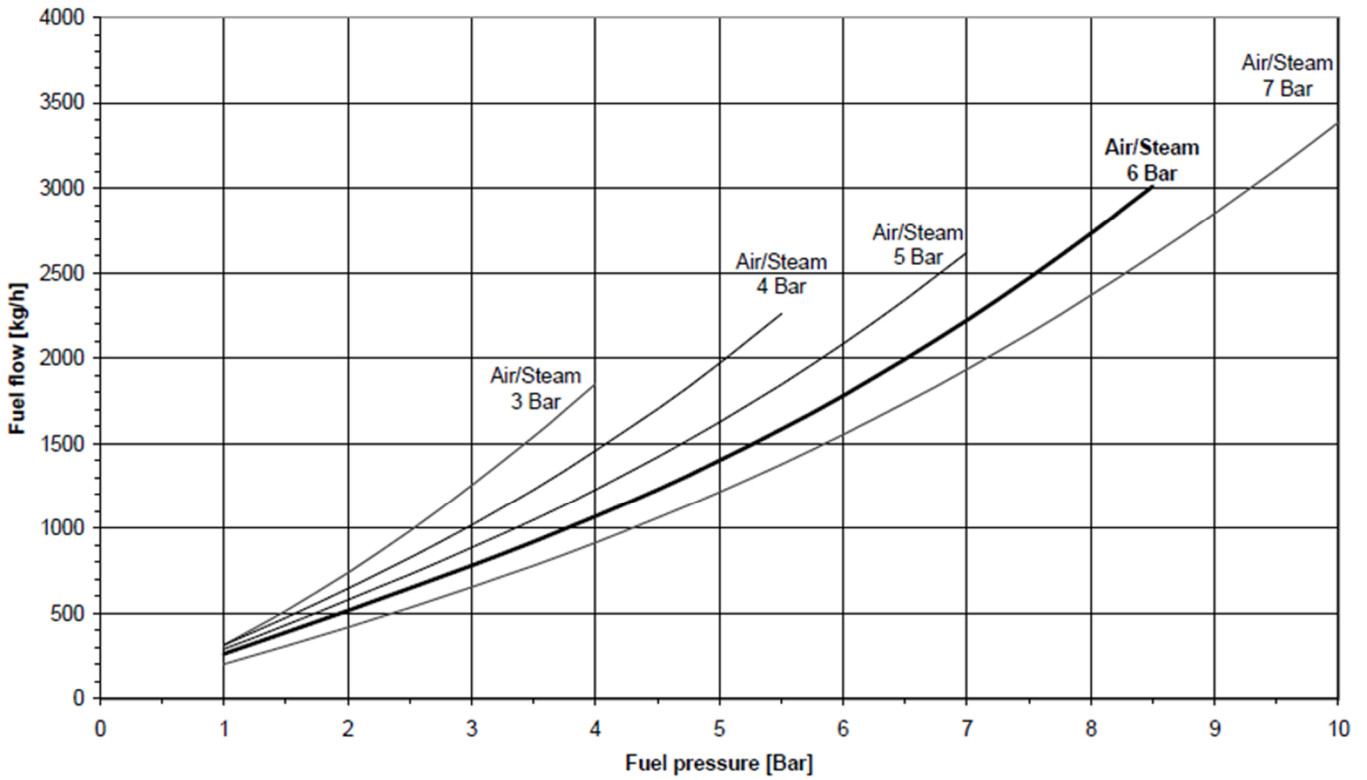

➤ **ECO 800.3 & ECO 900.1**

Atomizer 40-Y-A°-13-10 with reverse disc

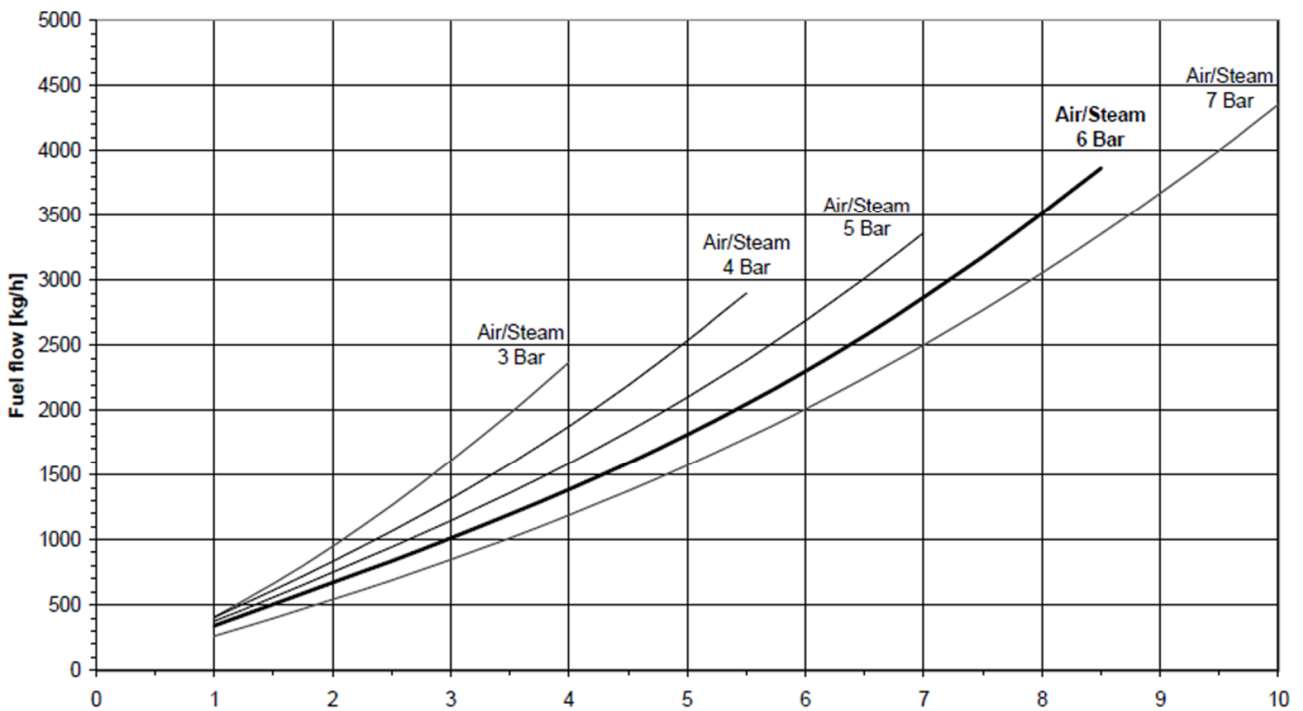

Pump Operating Pressure 25 Bar

➤ ECO 900.3

Atomizer 40-Y-A°-14-10 with reverse disc

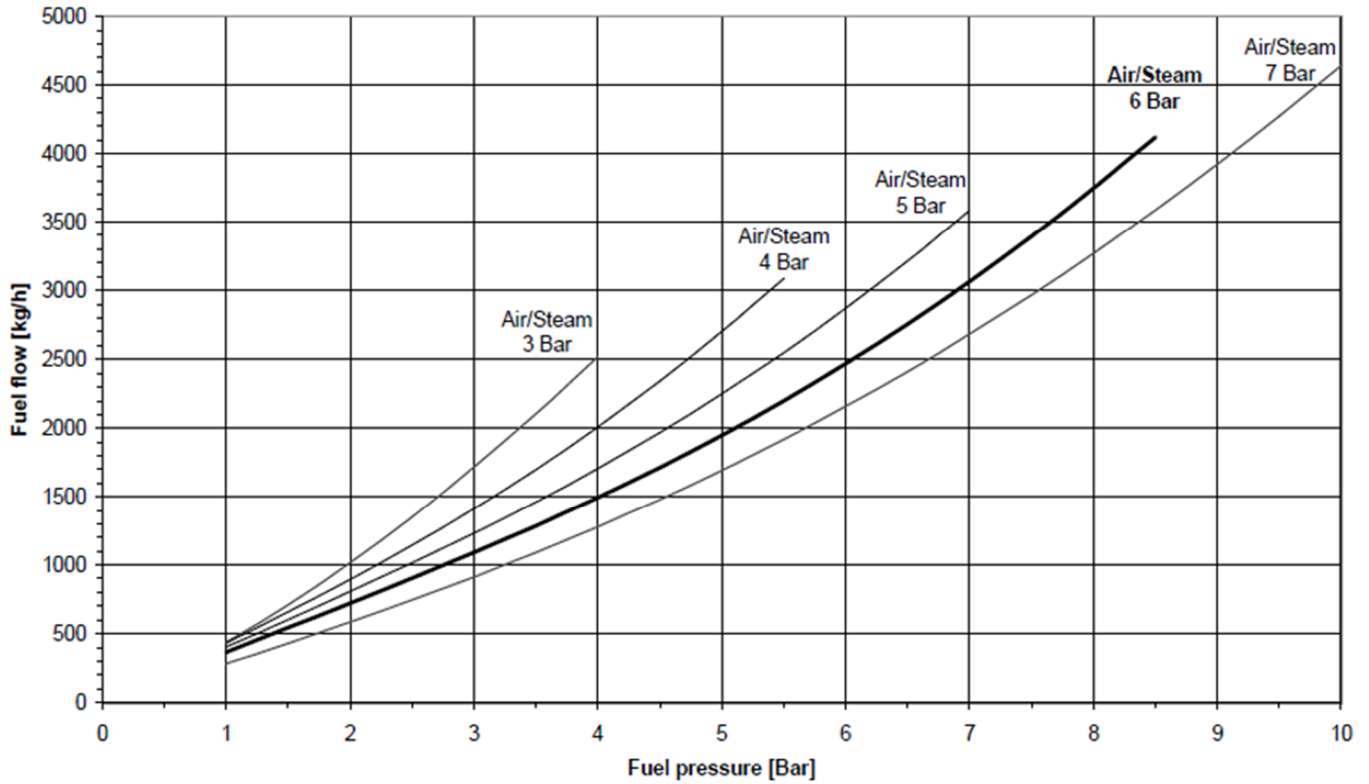

Pump Operating Pressure 25 Bar

6.6. Oil Adjustment Regulator

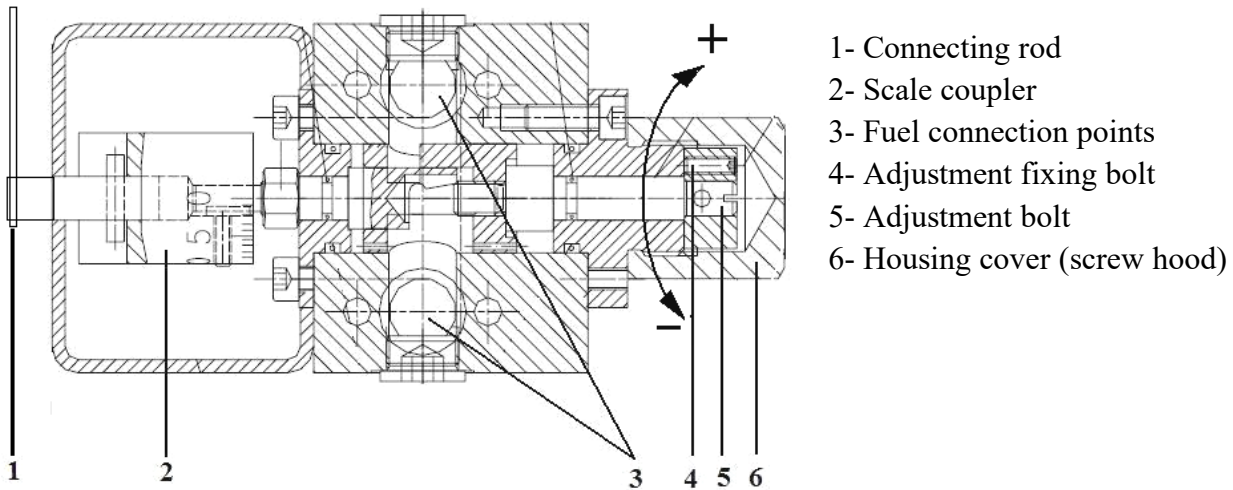

Fuel Regulator Adjustment

1-Remove the housing cover number 6

2-Loosen the fixing bolt number 4

3-When you rotate the shaft number 5 (when looked from the shaft end) clockwise, the pressure value you observe from return manometer will increase, and burner consumption will also increase since nozzle pressure increases.

4-When you rotate the shaft number 5 (when looked from the shaft end) anti-clockwise, the pressure value you observe from return manometer will decrease, and burner consumption will also decrease since nozzle pressure decreases.

5-When the adjustment is completed, make sure that the adjustment you have made is permanent by tightening the fixing bolt number 4.

6-Place the housing cover number 6.

6.7. Oil Burner Ring Line

HEAVY OIL P&ID
MECHANICAL CRACKING ATOMIZATION

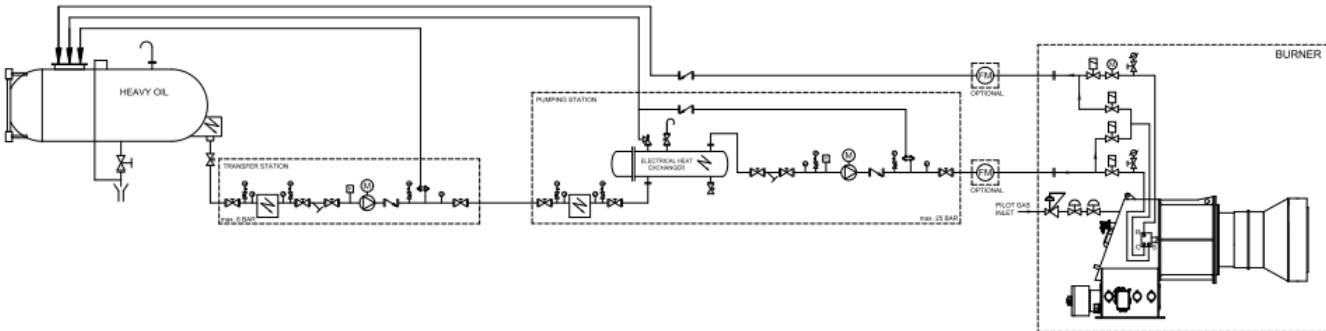

HEAVY OIL P&ID
AIR CRACKING ATOMIZATION

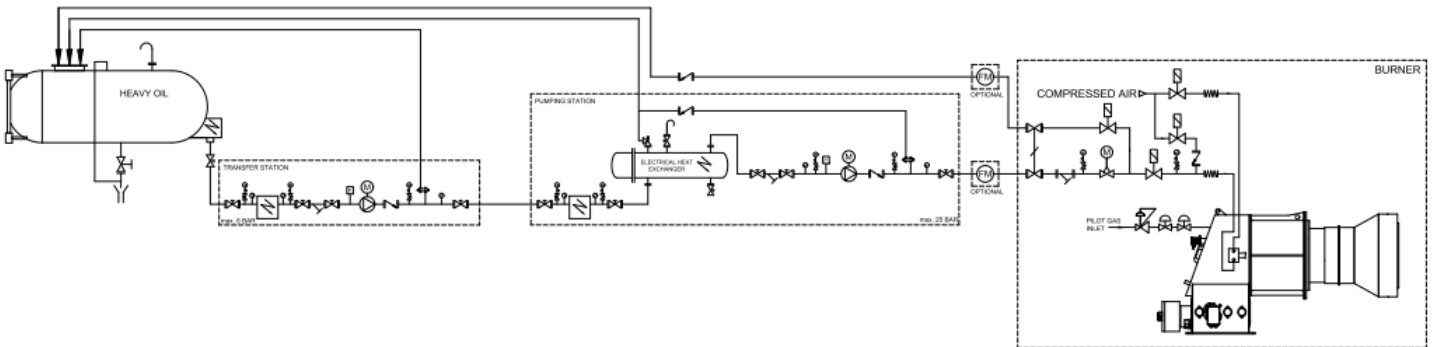

	BALL VALVE
	MANOMETER PRESSURE GAUGE
	THERMOMETER
	FUEL FILTER
	Y TYPE STRAINER
	PRESSURE SWITCH
	PUMP and MOTOR
	CHECK VALVE
	RELIEF VALVE
	SOLENOID VALVE
	PROPORTIONAL MOTORIZED VALVE
	FLOW METER
	ELECTRICAL HEAT EXCHANGER
	PILOT GAS REGULATOR
	RELIEF VALVE

6.8. Servomotor Adjustment



Do not open servomotor. Do not interfere with. It may damage servomotor or change burner settings.

6.9. Emission Measurement

In emission measurements, the following values are accepted as reference according to TS EN 267 standard.

- $\text{CO} < 110 \text{ mg/ kWh}$
- $\%3 \leq \text{O}_2 \leq \%5$
- $\text{NO}_x < 250 \text{ mg/ kWh}$
- Excess air ratio $1,2 \leq \lambda \leq 1,3$



It is important for the boiler to be sealed in order to avoid incorrect measurements during emission measurements.



Boiler temperature must be between 40 C° and 80 C° while making emission measurement in hot water boilers.

6.10. Program Relay

➤ LAL...



Control sequence under fault conditions and lockout indication

Whenever a fault occurs, the sequence switch stops and with it the lockout indicator.

The symbol appearing above the reading mark indicates the type of fault:

◀	No start	<ul style="list-style-type: none"> • One of the contacts is not closed (also refer to «Preconditions for burner startup») • Extraneous light: Lockout during or after completion of the control program Examples: <ul style="list-style-type: none"> – Nonextinguished flame – Leaking fuel valves – Faulty flame supervision circuit
▲	Interruption of startup sequence	<ul style="list-style-type: none"> • No «OPEN» signal at terminal 8 from the changeover end switch «a» • Terminals 6, 7 and 15 are live until fault has been corrected
P	Lockout	Does not apply to LAL1...: <ul style="list-style-type: none"> • No air pressure indication at the beginning of the air pressure check • Air pressure failure after the air pressure check
■	Lockout	<ul style="list-style-type: none"> • Defect in the flame supervision circuit
▼	Interruption of startup sequence	<ul style="list-style-type: none"> • No positioning signal at terminal 8 from the auxiliary switch «m» for the low-fire position • Terminals 6, 7 and 15 are live until fault has been corrected
1	Lockout	<ul style="list-style-type: none"> • No flame signal at the end of the safety time «TSA»
I	Lockout	<ul style="list-style-type: none"> • Flame signal has been lost during operation

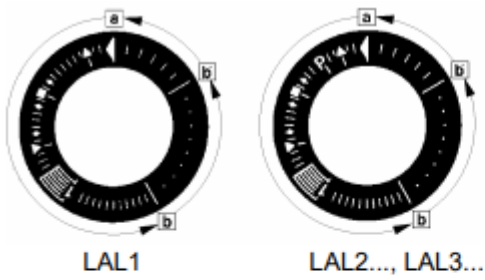

- a-b Startup sequence
- b-b' Idle steps
(with no contact confirmation)
- b (b')-a Postpurge program

- Burner control can immediately be reset after lockout:
 - Do not press the lockout reset button for more than 10 seconds
- The sequence switch always travels to the start position first
 - After resetting
 - After rectification of a fault that led to shutdown
 - After each power failure
 During this period of time, power is only fed to terminals 7 and 9...11.
- Then, the LAL.... will program a new burner startup sequence

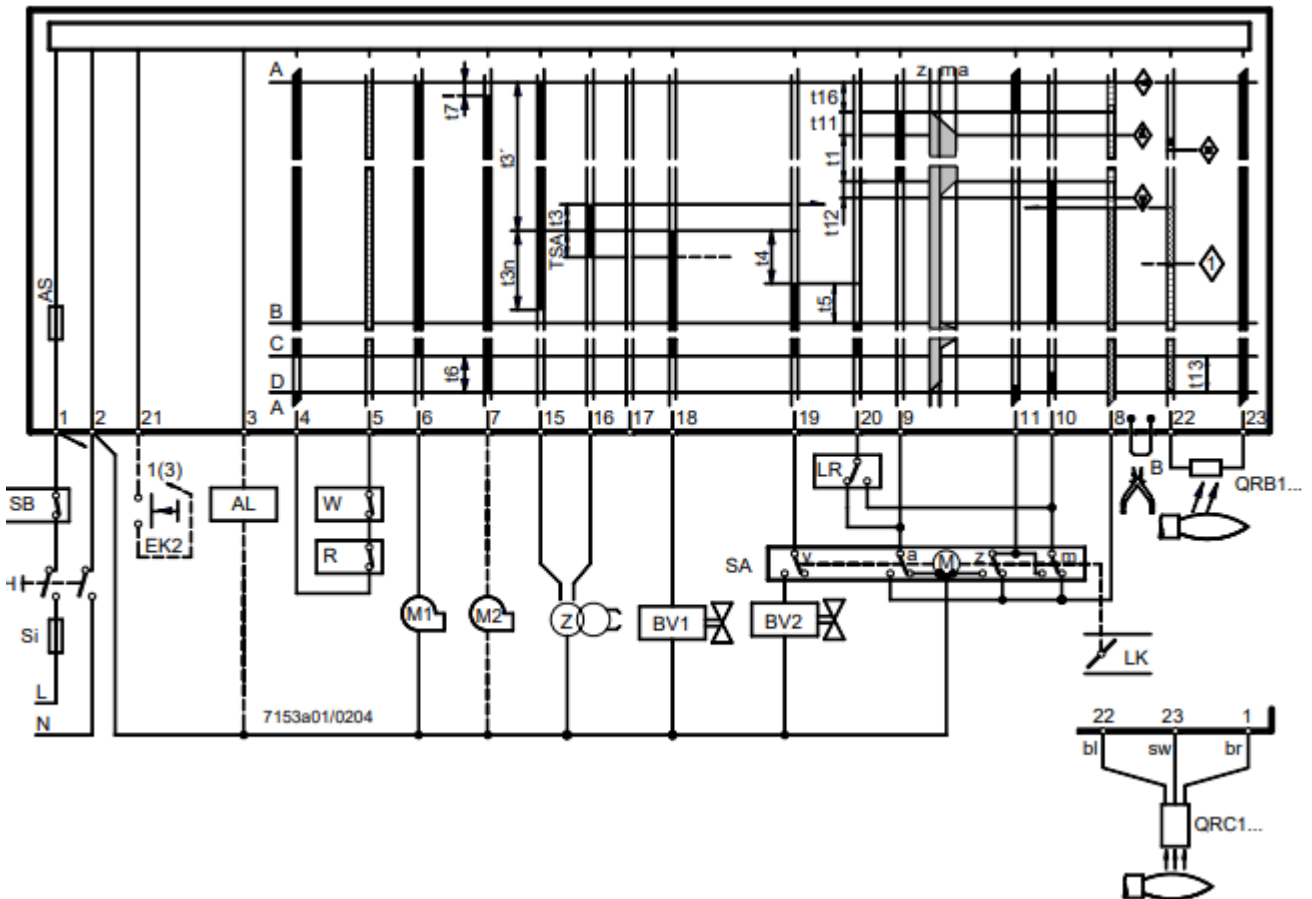

7. MAINTENANCE

7.1. Weekly Maintenance

Weekly maintenance is a routine cleaning and adjustment procedure which is performed to ensure smooth and continuous operation of the system. Burner components must be adjusted after each maintenance work in accordance with the instructions. Otherwise, the burner cannot be operated efficiently.

- Clean all filters in fuel ring system.
- Clean fuel nozzle of the burner.
- If the fin spaces and surface of the diffuser are covered with particles and formed a layer, clean it with a wire brush.
- Clean heads of ignition electrodes. Check by performing manual ignition, adjust the distance between the ignition electrode and diffuser according to the adjustment instructions.

7.2. Monthly Maintenance

Monthly maintenance is a more comprehensive maintenance compared to weekly maintenance, where general checks of burner and peripheral components are performed to prevent possible faults. After completion of maintenance and adjustment processes, make sure to perform a combustion analysis.

- Clean the filters on the fuel line to the burner.
- Clean fuel nozzle of the burner.
- Clean the surface of the diffuser.
- Clean flame pipe.
- Check all wiring points. Tighten loose connections.
- Clean the solenoid valves.
- Clean the photocell.
- Clean the dust and layers accumulated on the fan and air valves.
- Check pump pressure. Check if necessary (Heavy Oil: 25 bar)
- Check ignition electrodes. Adjust it if necessary. Check ignition cables and sockets.
- Perform cleanliness control of inside panel. Clean if necessary.
- Check all bolts of the burner. Tighten loose bolts.
- After starting the burner and adjusting air dameper, perform flue gas analysis and check if there is an ideal combustion.

7.3. Seasonal Maintenance

Comprehensive maintenance work when the burner is restarted after long periods of shut-down or interruptions. After completion of maintenance and adjustment processes, make sure to perform a combustion analysis.

- Check insulation resistance of electric motor.
- Make surface cleaning of ignition electrodes and porcelains. Replace cracked or broken porcelains.
- Clean air fan and clamps.
- Check the operating function.
- Check cleanliness of the nozzle. Replace it if necessary.
- Clean the N.C. solenoid valve. Measure the coil winding resistance.
- Clean the strainer (filter) under the pump cover.
- Clean the photocell.
- Clean fuel filter. Replace it if necessary.
- Check boiler thermostats.
- Check cleanliness of boiler inside and clean if necessary.

8. TROUBLESHOOTING

Problem	Cause	Explanation-Suggestion
Burner cannot be commissioned	Fuel is cut or does not come	Fuel valve might be closed. Open the valve.
	Fuse failure	Check burner power supply. The fuse on the main panel or the fuse on the burner might be tripped.
	Relay failure	Reset the thermal relay. Check adjustment of the thermal relay according to the current in motor label. If the failure is not removed, replace the thermal relay.
	Boiler thermostat, pressure switch failure	If there is a problem with the burner thermostats, pressure switches and steam tank this may be due to an unadjusted or faulty water level device; adjust it and if broken, replace it.
Flame appears and goes into failure mode.	Fuel pressure error	Circuit fuel pressure might have dropped.
	Photocell failure	Photocell may be faulty or contaminated. Remove and clean..
	Program relay failure	Replace it with a new one.
Burner starts up, but fails after 10 seconds.	Program relay failure	Replace it with a new one.
	Fan motor failure	Check fan motor coils, motor contactor and outlet from program relay.
Burner starts up, but fails after 30 seconds.	Fuel valve, fuel pressure drop	Fuel valve might be closed. Supply fuel pressure might be low. Check fuel inlet manometer.
	Ignition electrode failure	Ignition electrodes might be misadjusted or ignition cables might have come out of their terminals. Adjust ignition electrodes with a distance of 3-5 mm. between them.
Boiler cover is overheating.	Sealing problem	Ensure sealing between the boiler cover and burner. If required, use insulating material between the boiler connecting flange and boiler cover.

9. PERIODICAL FLUE GAS MEASUREMENT REPORT								
Fuel Consumption (kg/h)	CO (ppm)	O₂ (%)	CO₂ (ppm)	NO_x (ppm)	Yield (%)	Flue Temp. (°C)	Date	Signature

10. AFTER SALES SERVICES

Dear Customer,

We believe that providing a good service is as important as providing a good product. Therefore, we continue offering wide range of comprehensive services to our conscious customers.

For your suggestions, complaints and service requests

Esentepe Mah. Milangaz Cad. No:75 K:3

Kartal Monumento Plaza

KARTAL/İSTANBUL/TÜRKİYE

Tel: 444 8 326

Fax: +90 216 370 45 03

Factory Contact Details

Türkgücü OSB

Bülent Ecevit Bulvarı No:11

ÇORLU/TEKİRDAĞ/TÜRKİYE

Tel: +90 282 685 44 80-81

Fax: +90 282 685 42 09

Also you can contact with us:

Web site : www.ecostar.com.tr

E - mail : servis@ecostar.com.tr



Please observe the following recommendations.

- Use the product in accordance with the principles of this manual.
- For any service demands regarding the product, please contact our Service Center from the abovementioned phone numbers.
- Upon your purchase, register your warranty certificate during installation.

