

MONOBLOCK GAS BURNERS INSTALLATION, OPERATING AND MAINTENANCE MANUAL

TWO STAGE AND MODULATING OPERATION

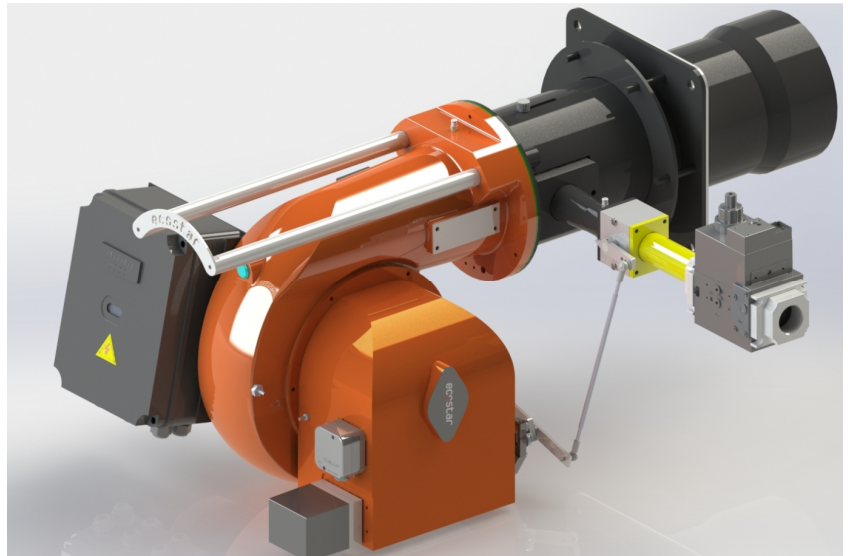

ECO 50
ECO 55
ECO 60
ECO 65
ECO 70
ECO 75

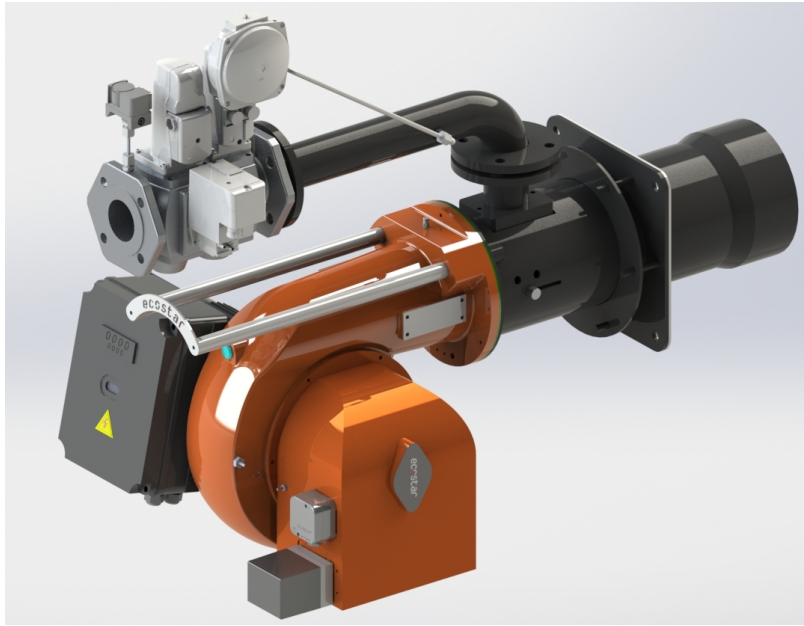

DEAR USER,

ECOSTAR ECO 50, ECO 55, ECO 60, ECO 65, ECO 70, ECO 75 Gas burners are prepared and manufactured according to the latest technical developments and safety rules. It is easy to use for our customers.

We recommend that you read this manual and safety warnings thoroughly before the use of the device in order to ensure safe, cost effective and environmental-friendly use.

If you encounter any issue that is not explained clearly in this manual or you could not understand, please contact with our service department.

We thank you for choosing ECOSTAR brand.

Ecostar Gas Burners are manufactured in accordance with TS EN 676 +A2 standards.











This Operating Manual is an integral part of the burner and must be maintained in a plastic dossier and hung at a clearly visible place in the burner room.

CONTENTS

1. WARNINGS	3
1.1. Warning Symbols and Descriptions	3
1.2. General Safety Rules	4
2. TERMS OF WARRANTY	6
2.1. Out of Warranty Conditions	6
3. BURNER'S GENERAL FEATURES	7
3.1. Purpose of Use and Work Limits of Burners	7
3.2. Code Key	7
3.3. Burner Components	8
4. GAS, FLUE GAS AND HEATING WATER SCHEMA	13
5. TECHNICAL DATA	14
5.1. Capacity Table	14
5.2. Back Pressure-Capacity Diagrams	15
5.3. Burner Dimensions	17
5.4. Gas Hood Pressure Loss Diagram	19
5.5. Flame Length and Diameter	22
5.6. Noise Level	22
6. BURNER HANDLING INFORMATION	22
7. INSTALLATION	24
7.1. Burner Installation Picture	24
8. COMMISSIONING	25
8.1. Before Commissioning	25
8.1.1. Ignition and Ionizasyon System	25
8.2. General Controls	26
8.3. Combustion Adjustment	27
8.3.1. Gas Adjustment	27
8.3.1.1. VGD 20 4011 - 5011 Series Gas Valve	27
8.3.1.2. MB DLE Series Monoblock Gas Valve	28
8.3.1.3. MB ZRD(LE) 415 – 420 Series Gas Valve	30
8.4. Air Pressure Switch Adjustment	31
8.5. Servomotor Adjustment	31
8.6. Emission Measurement	32
8.7. Capacity Adjustment	32
8.8. Program Relay	32
8.9. Function Controls and Adjustments	33
8.10. Final Checks	33
8.11. Gas Pass Equipment Required in Gas Line	36
9. MAINTENANCE	37
9.1. Monthly Maintenance	37
9.2. Seasonal Maintenance	37
9.3. Installation And Disassembly Instructions For Maintenance Purposes	38
10. TROUBLESHOOTING	41
11. PERIODICAL FLUE GAS MEASUREMENT REPORT	42
12. AFTER-SALES SERVICES	43
13. NOTES	44

1. WARNINGS

1.1. Warning Symbols and Descriptions

Symbols	Symbol Descriptions
	Important information and useful hints.
	Warning of danger to life or property.
	Warning of electrical voltage.
	Product handling information.
P_F	Impulse connection detecting combustion chamber pressure
P_L	Impulse connection detecting combustion air pressure
P_{BR}	Impulse connection detecting burner gas head
 CLEAN THE GAS BURNER. CLEAN GAS LINE. ЧИСТАЯ ЛИНИЯ ГАЗ.	"Clean the gas line" warning on gas line.
	Electric motor direction of rotation
   	Carry in an upright position. Fragile Item. Protect against water.

1.2. General Safety Rules

- All personnel engaged in installation, disassembly, commissioning, operation, control, maintenance and repair should have received the necessary training and fully read and understood this manual.
- No changes that might damage the safety of the burner unit must be made by persons and/or organizations on the burner unit.
- All operation, commissioning and installation works (except for burning adjustment) should be carried out when the burner is not operating and after disconnecting the power supply. Noncompliance with these rules may lead to serious bodily injuries and even death by electrical shocks or uncontrolled flame formation.
- Repairs concerned with safety elements should be carried out only by the manufacturing company.
- The device should never be used by children, mentally handicapped and inexperienced persons.
- Children must not be allowed to play with the device.
- Keep the device away from explosive and flammable materials.
- Device must intake air, ventilation and air discharge holes must not be closed.



If you sense gas leakage;

- Shut down valves of all gas devices.
- Open all doors and windows.
- Do not turn on electric devices or do not turn them off if they are working.
- Do not use burner derived tools such as match and lighter.
- Inform the gas company.



Do not store any inflammable materials in boiler room.



Wear hearing protectors if there is noise in boiler room.



In case of fire or other emergency;

- Switch off the main switch
- Close the main fuel shut-off valve outside the plant.
- Take appropriate actions



The burner installation must be carried out in accordance with the instructions. Vibration can damage the burner and its components.



Keep boiler doors closed while starting burner and during burner operation.



Check combustion values to be correct by using flue gas analyzer at the whole adjustment range between minimum, full load, and ignition load.



Use lifting device or belt for lifting fan motor, if necessary



During the first commissioning of the burner or in case of any revision carried out in the electrical system or motor cables by any reason, direction of the fan rotation must certainly be checked by the authorized technical service.



For products that have not been commissioned or started more than 6 months, before activating the servomotor;

In gas and air dampers, servomotor and air damper connections must be checked to ensure that they are free running in spite of immobility and oil freezing.



BURNER ROOM

Install the burner in a suitable room/floor with minimum external air openings and sufficient to ensure perfect combustion, in compliance with current regulations.

Never obstruct air openings of the burner room, burner fan intake vents or air ducts in order to prevent:

- a. The build up of toxic / explosive gas mixtures in the burner room,
- b. Combustion with insufficient air, resulting in hazardous, anti-economical and polluting operation.

The burner must be always protected from rain, snow and frost to prevent corrosion and paint deformations.

Keep the burner room clean and free of solid volatile substances, which could be sucked into the fan and clog the internal burner or combustion head air ducts.

2. TERMS OF WARRANTY

Main and auxiliary equipment and all components used in Ecostar gas burners are guaranteed for 1 year by TERMO ISI SİST. A.Ş starting from the date of commissioning under the maintenance, adjustment, operating conditions and relevant mechanic, chemical and thermal effects explained herein.



Please note that this warranty is only valid if the device(s) is commissioned and maintained by our authorized services.



Our company reserves the right to make any modifications on the product and all instructions thereof for improvement purposes.

2.1. Out of Warranty Conditions

- Any damage arising out of or in relation to customers' non-compliance to their responsibilities with regards to installation, commissioning, operation and maintenance,
- Any damage arising out of or in relation to commissioning, repairs and maintenance carried out by unauthorized services,
- Any damage that may occur during transportation or storage of the product,
- Not preserving the product in its original packaging until the installation stage,
- Incorrect and poor electrical connections, Failures due to incorrect voltage applications, frequent repetition of voltage fluctuations,
- Any damage that may occur as a result of incorrect fuel usage or, foreign substances in the fuel used or using of the product without any fuel,
- Any damage that may occur due to foreign particles entered into the product during installation and operation,
- Failures due to incorrect device selection,
- Any damage to unit due to natural disasters,
- Devices without any warranty certificates,
- Warranty Certificates without the stamp and signature of the authorized dealer or service,
- Devices with any falsification on the warranty certificate or without an original serial number.
- The risks during transportation of device under the responsibility of customer belong to the customer.
- Presence of misuse faults are indicated in the reports issued by authorized service stations or our authorized agent, dealer, representative or our factory in case of unavailability of authorized service stations.
- Customers may apply consumer protection arbitrator committee with regards to this report and request for an expert report.

3. BURNER'S GENERAL FEATURES

ECOSTAR gas burners are manufactured such that they operate in gas pressure of min. 20 mbar and max. 300 mbar., at 15%...+10% of nominal voltage, between the ambient temperature range of -15°C...+60°C and declared capacity and boiler pressure ranges with Natural Gas and Liquid Petrol Gas.

3.1. Purpose of Use and Work Limits of Burners

- This product works at any load value equivalent to its max. capacity or covered by its capacity range;
 - In hot water and steam boilers,
 - In direct and indirect hot air generators,
 - Industrial appliances operating at temperature below 600 °C,
 - -15 °C...+60 °C ambient temperature range,
 - 1N 230 VAC/3N 380VAC /50 Hz feed voltage (-%15...+%10) values,
 - Max. 95% relative humidity,
 - In well-ventilated open and closed spaces compatible with protection class IP 40.
 - Operation with Natural gas and LPG.



This device must never be operated with open flame!

3.2. Code Key

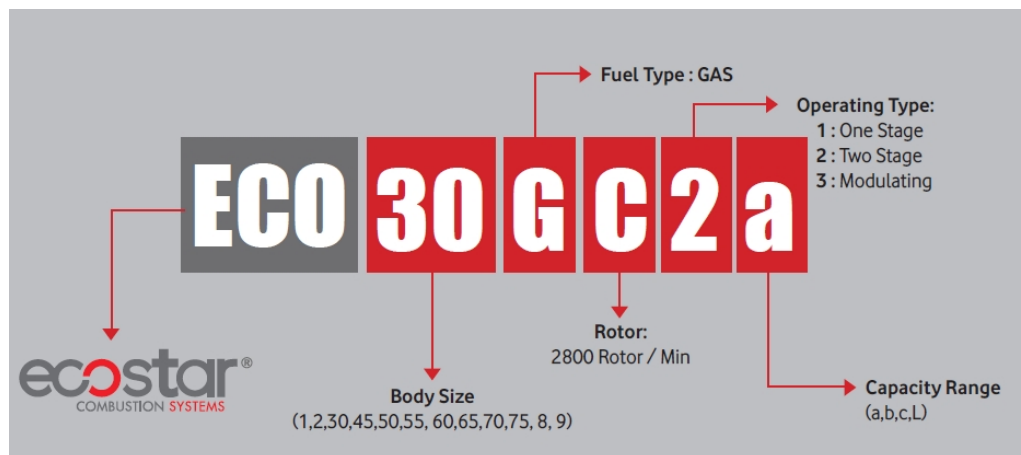

3.3. Burner Components

ECO 50, ECO55

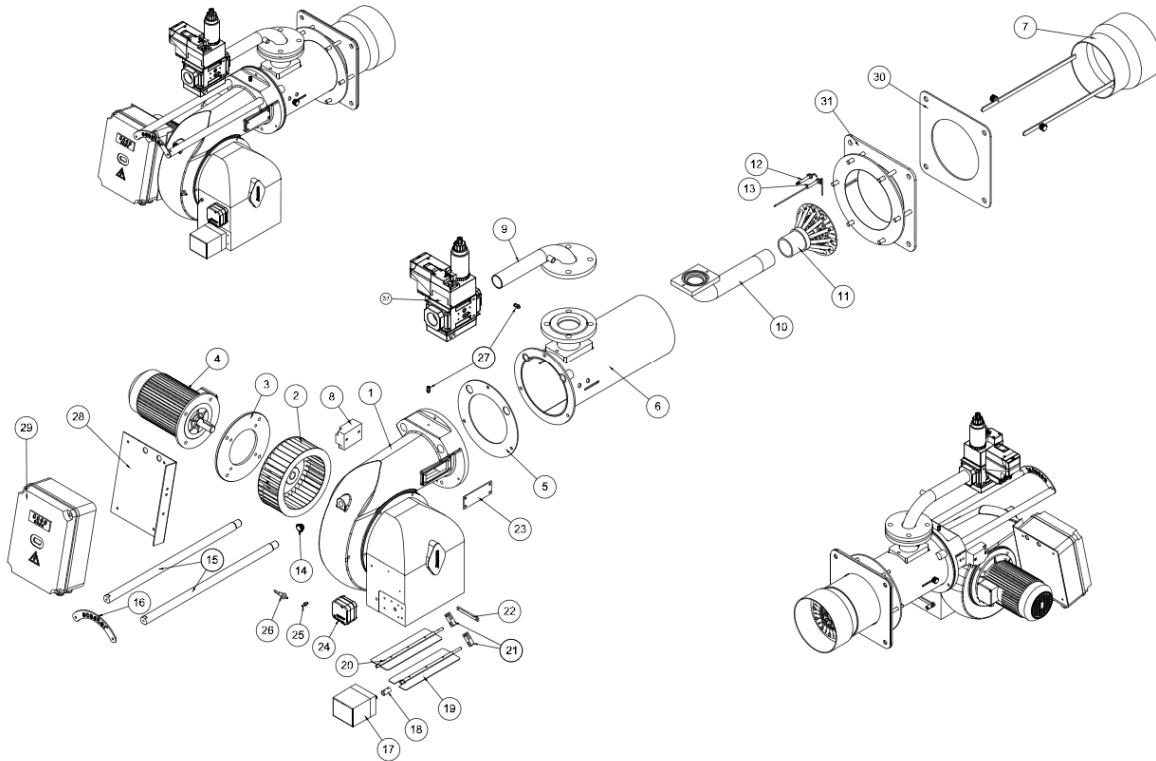

Assembly No	Part Name	Assembly No	Part Name
1	Body Group	17	Servomotor
2	Fan	18	Servomotor Coupling
3	Fan Motor Mounting Flange	19	Air Damper Short
4	Fan Motor	20	Air Damper Long
5	Gasket	21	Damper Motion Rod
6	Flame Tube	22	Air Damper Motion Transfer Rod
7	Flame Tube Extension	23	Lance Cover
8	Transformer	24	Pressure Switch
9	Gas Train Pipe	25	Pressure Switch Adaptor
10	Combustion Head Elbow	26	Pressure Switch Adaptor Pipe
11	Combustion Head	27	Purger
12	Ignition Electrode	28	Electrical Panel Mounting Plate
13	Ionization Electrode	29	Electrical Panel
14	Observation Glass	30	Gasket
15	Handling Shaft	31	Boiler Connection Flange
16	Handling Shaft Fixing Plate	32	Gas Valve

ECO 50, ECO 55 Mechanical Modulation

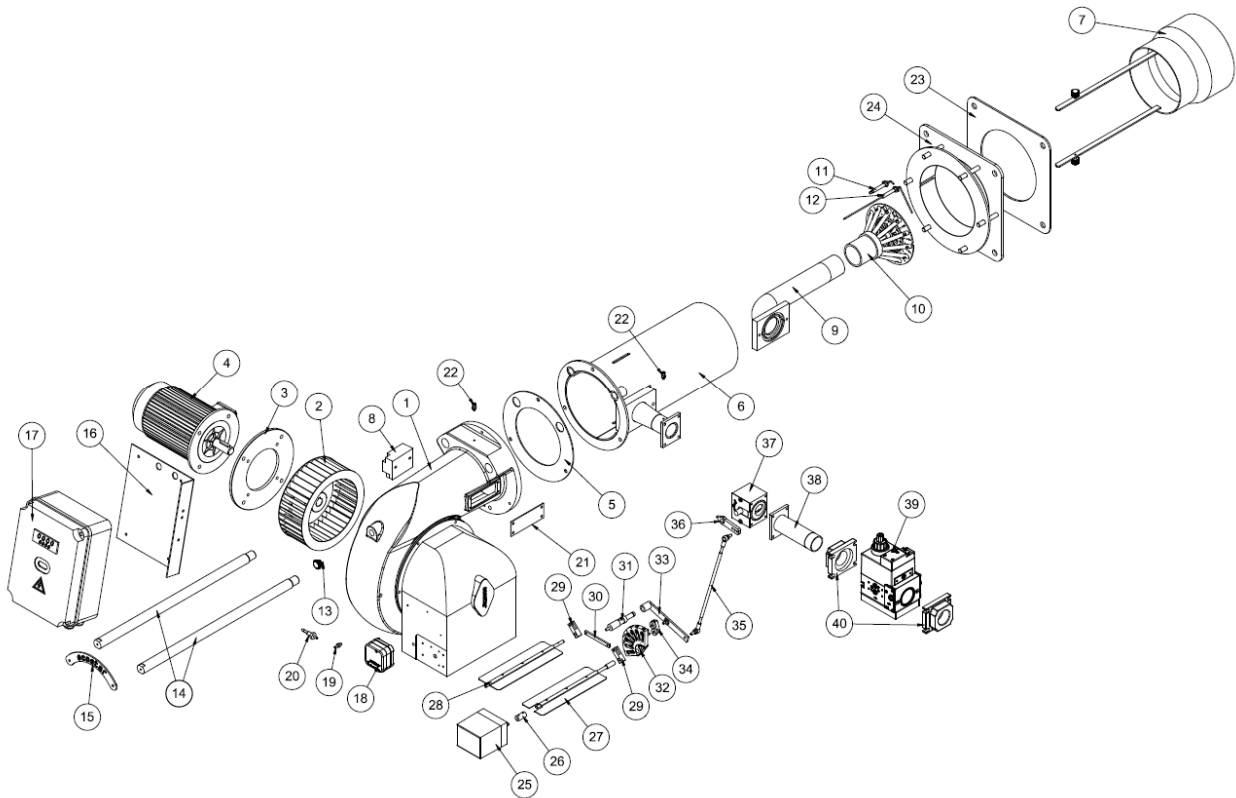

Assembly No	Part Name	Assembly No	Part Name
1	Body Group	21	Lance Cover
2	Fan	22	Purger
3	Fan Motor Mounting Flange	23	Gasket
4	Fan Motor	24	Boiler Connection Flange
5	Gasket	25	Servomotor
6	Flame Tube	26	Servomotor Coupling
7	Flame Tube Extension	27	Air Damper
8	Transformer	28	Air Damper
9	Combustion Head Elbow	29	Damper Motion Rod
10	Combustion Head	30	Air Damper Motion Transfer Rod
11	Ignition Electrode	31	Lever Mounting Shaft
12	Ionization Electrode	32	Cam
13	Observation Glass	33	Lever
14	Handling Shaft	34	Bearing Group
15	Handling Shaft Fixing Plate	35	Connecting Rod
16	Electrical Panel Mounting Plate	36	Gas Adjustment Arm
17	Electrical Panel	37	Gas Adjustment Valve
18	Pressure Switch	38	Gas Supply Pipe
19	Pressure Switch Adaptor	39	Gas Valve
20	Pressure Switch Adaptor Pipe	40	Gas Flanges 1 1/2"

ECO 60

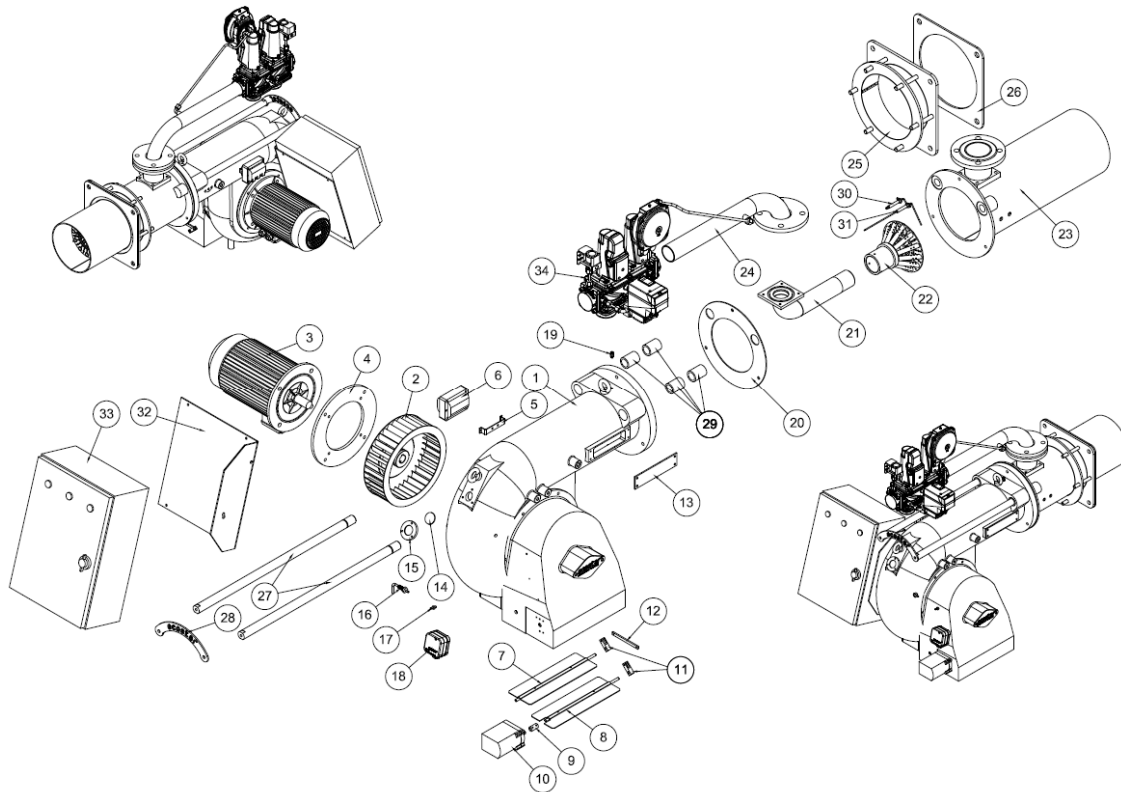

Assembly No	Part Name	Assembly No	Part Name
1	Body Group	18	Pressure Switch
2	Fan	19	Purger
3	Fan Motor	20	Gasket
4	Fan Motor Mounting Flange	21	Combustion Head Elbow
5	Transformer Mounting Plate	22	Combustion Head
6	Transformer	23	Flame Tube
7	Air Damper Long	24	Gas Train Pipe
8	Air Damper Short	25	Boiler Connection Flange
9	Servomotor Coupling	26	Gasket
10	Servomotor	27	Handling Shaft
11	Damper Motion Rod	28	Mil Fixing Plate
12	Motion Handling Rod	29	Bearing
13	Lance Cover	30	Ignition Electrode
14	Observation Glass	31	Ionization Electrode
15	Observation Glass Frame	32	Electrical Panel Mounting Plate
16	Pressure Switch Pipe	33	Electrical Panel
17	Pressure Switch Adaptor	34	Gas Valve

ECO 65 - ECO 70

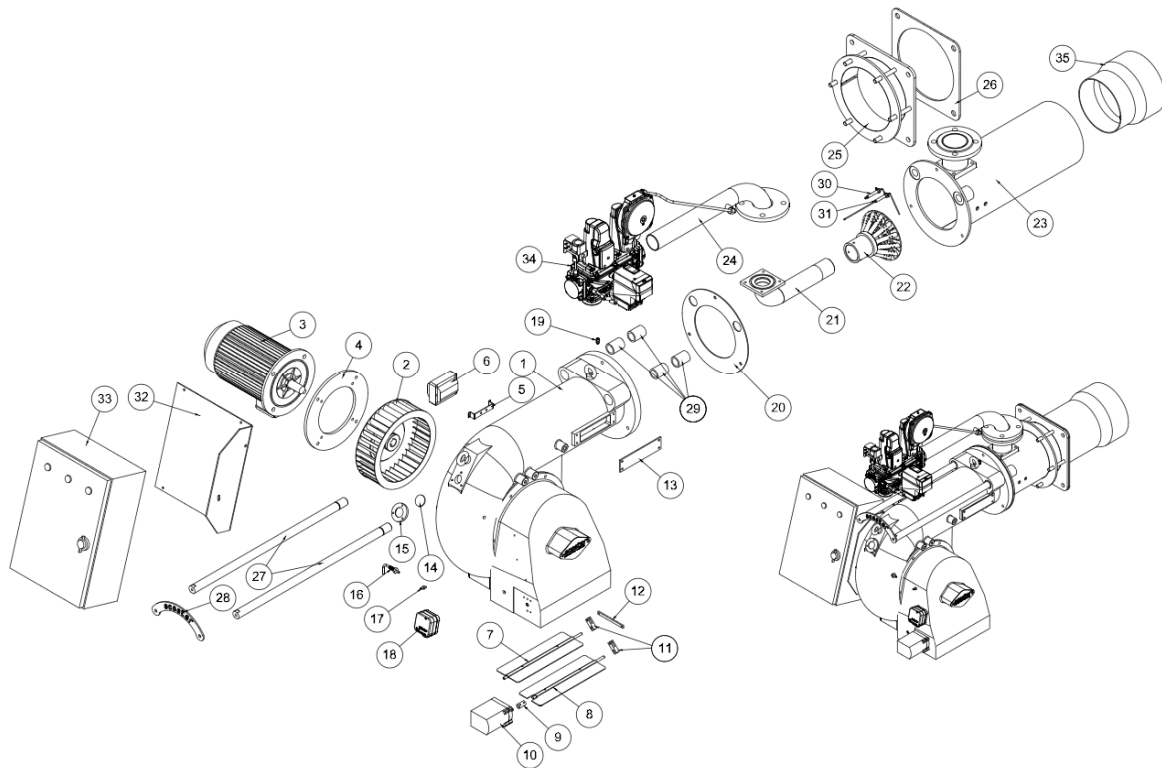

Assembly No	Part Name	Assembly No	Part Name
1	Body Group	19	Purger
2	Fan	20	Gasket
3	Fan Motor	21	Combustion Head Elbow
4	Fan Motor Mounting Flange	22	Combustion Head
5	Transformer Mounting Plate	23	Flame Tube
6	Transformer	24	Gas Train Pipe
7	Air Damper Long	25	Boiler Connection Flange
8	Air Damper Short	26	Gasket
9	Servomotor Coupling	27	Handling Shaft
10	Servomotor	28	Mil Fixing Plate
11	Damper Motion Rod	29	Bearing
12	Motion Handling Rod	30	Ignition Electrode
13	Lance Cover	31	Ionization Electrode
14	Observation Glass	32	Electrical Panel Mounting Plate
15	Observation Glass Frame	33	Electrical Panel
16	Pressure Switch Pipe	34	Gas Valve
17	Pressure Switch Adaptor	35	Flame Tube Extension
18	Pressure Switch		

ECO 75

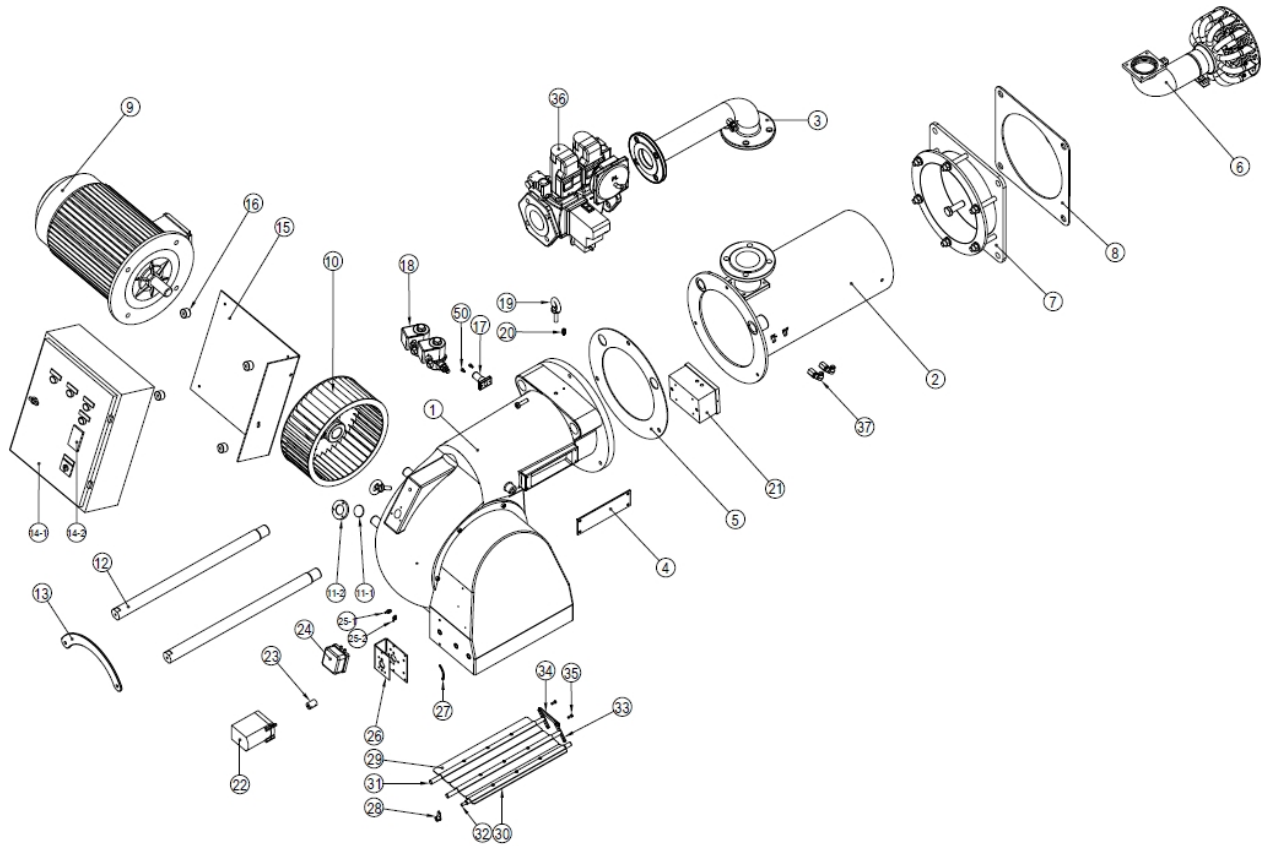

Assembly No	Part Name	Assembly No	Part Name
1	Body Group	19	Eye bolt
2	Flame Tube	20	Purger
3	Gas Train Pipe	21	Transformer Box
4	Lance Cover	22	Servomotor
5	Gasket	23	Servomotor Coupling
6	Combustion Head	24	Pressure Switch
7	Boiler Connection Flange	25-1	Pressure Switch Adaptor Pipe
8	Gasket	25-2	Pressure Switch Adaptor
9	Fan Motor	26	Servomotor Mounting Console
10	Fan	27	Servomotor Gauge
11-1	Observation Glass	28	Damper Gauge
11-2	Observation Glass Frame	29	Air Damper Plate (Wide)
12	Handling Shaft	30	Air Damper Plate (Narrow)
13	Handling Shaft Fixing Plate	31	Damper Shaft (with Groove)
14-1	Electrical Panel	32	Damper Shaft (Straight)
14-2	Process Controller	33	Motion Handling Rod
15	Electrical Panel Mounting Plate	34	Motion Handling Rod
16	Anti-Vibration Mount	35	Motion Handling Rod Shaft
17	Photocell	36	Solenoid Valve
18	Solenoid Valve		

4. GAS, FLUE GAS AND HEATING WATER SCHEMA

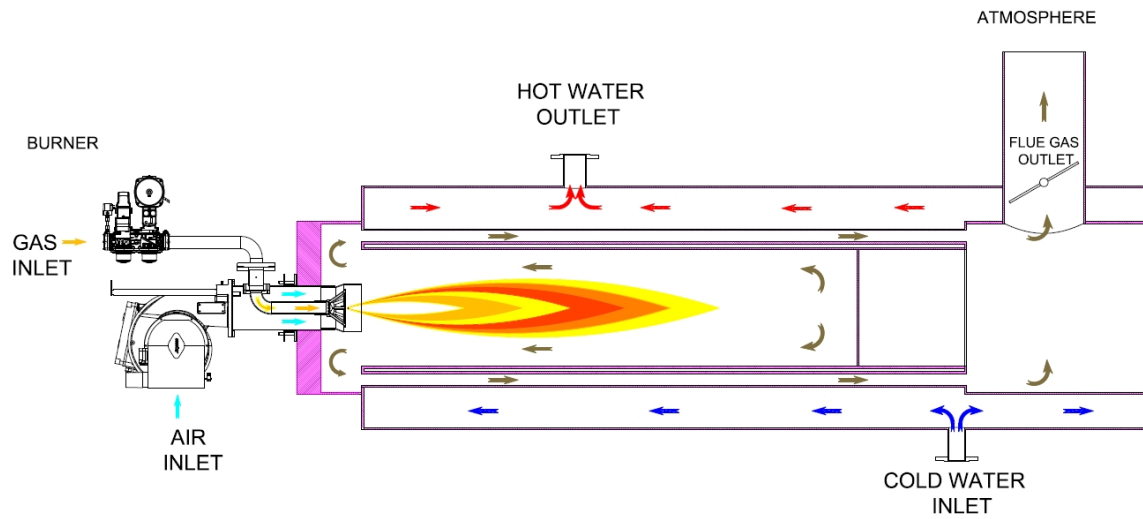

5. TECHNICAL DATA

5.1. Capacity Table

GAS BURNERS CAPACITY TABLE										
BURNER TYPE	CAPACITY		CAPACITY		NATURAL GAS CONSUMPTION		LPG GAS CONSUMPTION		FAN MOTOR POWER	MAIN SUPPLY
	Min. kcal/h	Max. kcal/h	Min. kW	Max. kW	Min. Nm ³ /h	Max. Nm ³ /h	Min. Nm ³ /h	Max. Nm ³ /h	kW	VAC
TWO STAGE GAS BURNERS										
ECO 50 G C 2	215.000	1.290.000	250	1.500	26,1	156,4	9,6	57,3	2,20	3N 380
ECO 55 G C 2	258.000	1.720.000	300	2.000	31,3	208,5	11,5	76,4	3,00	3N 380
ECO 55 G C 2a	258.000	2.150.000	300	2.500	31,3	260,6	11,5	95,6	3,00	3N 380
ECO 60 G C 2	369.800	2.580.000	430	3.000	44,8	312,7	16,4	114,7	4	3N 380
ECO 65 G C 2	430.000	3.010.000	500	3.500	52,1	364,8	19,1	133,8	5,5	3N 380
ECO 70 G C 2	498.800	3.500.200	580	4.070	60,5	424,3	22,2	155,6	7,5	3N 380
MODULATING GAS BURNERS										
ECO 50 G C 3	215.000	1.290.000	250	1.500	26,1	156,4	9,6	57,3	2,20	3N 380
ECO 55 G C 3	258.000	1.720.000	300	2.000	31,3	208,5	11,5	76,4	3,00	3N 380
ECO 55 G C 3a	258.000	2.150.000	300	2.500	31,3	260,6	11,5	95,6	3,00	3N 380
ECO 60 G C 3	369.800	2.580.000	430	3.000	44,8	312,7	16,4	114,7	4,00	3N 380
ECO 65 G C 3	430.000	3.010.000	500	3.500	52,1	364,8	19,1	133,8	5,5	3N 380
ECO 70 G C 3	498.800	3.500.200	580	4.070	60,5	424,3	22,2	155,6	7,5	3N 380
ECO 75 G C 3	686.280	4.800.000	798	5.581	83,2	581,8	30,5	213,3	11,00	3N 380

H_u Natural Gas =8250 kcal/Nm³

H_u LPG=22500 kcal/Nm³

5.2. Back Pressure-Capacity Diagrams

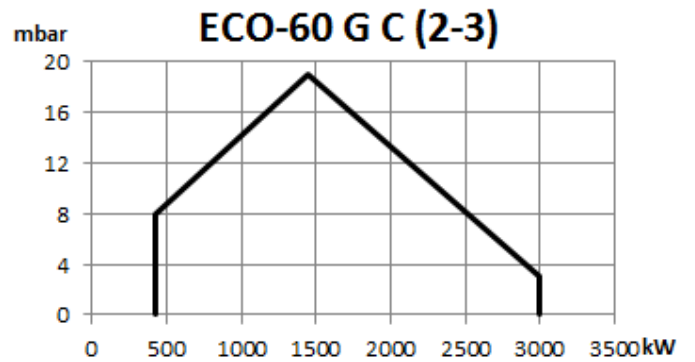
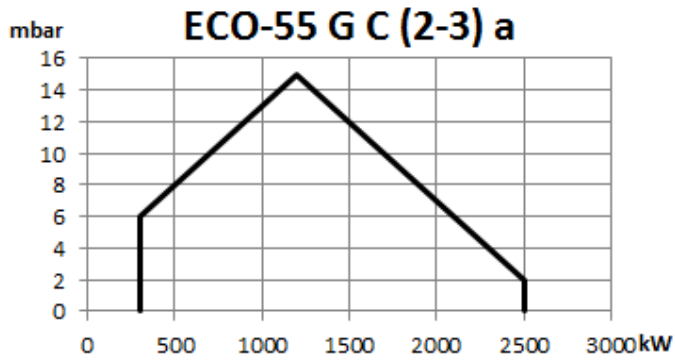
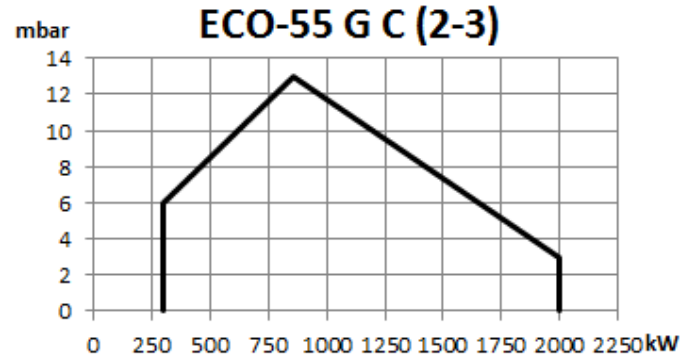
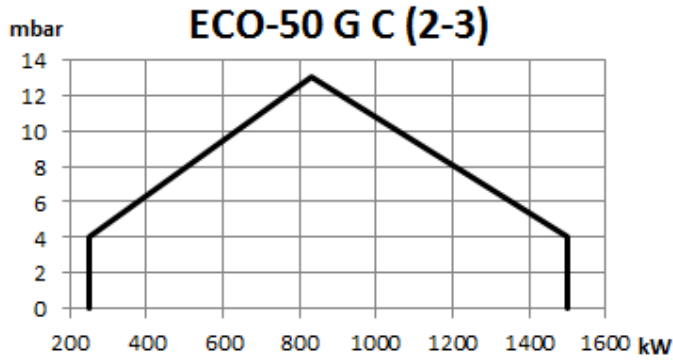

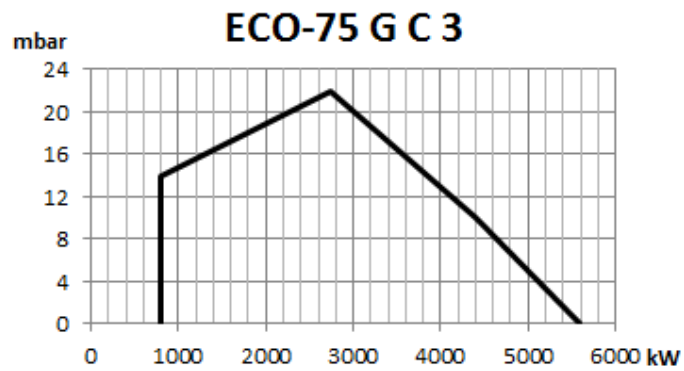
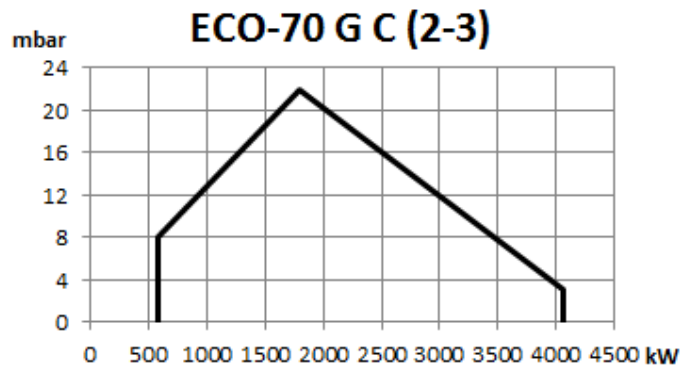
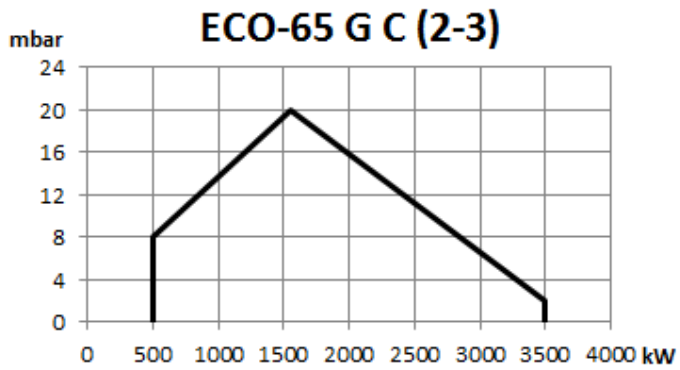

5.3. Burner Dimensions

ECO 50 ECO 55 ECO 65 ECO 70

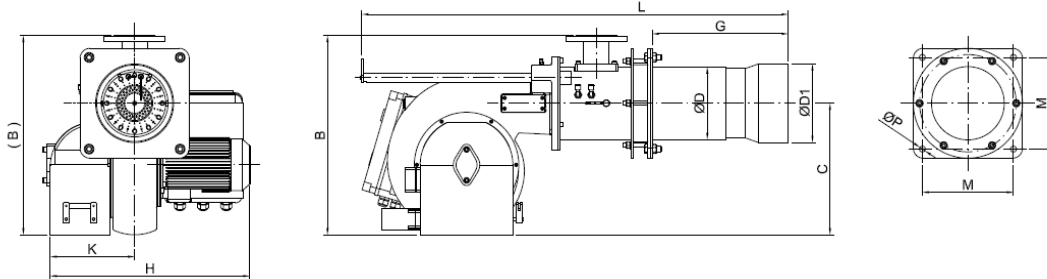

ECO 60 ECO 75

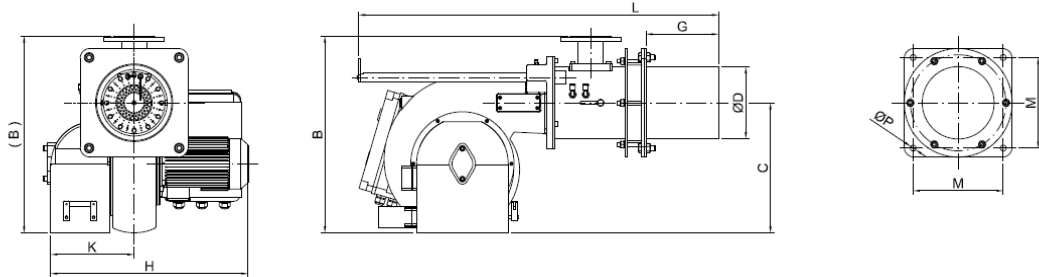

	L	Gmin	Gmax	H	K	B	C	ØP	M	ØD	ØD1
ECO 50 G	1300	280	440	650	255	625	422	18	275	218	236
ECO 55 G	1300	280	440	650	255	625	422	18	275	218	236
ECO 60 G	1450	200	355	850	330	730	510	18	275	240	-
ECO 65 G	1500	200	440	815	330	735	510	18	275	250	280
ECO 70 G	1500	200	440	820	330	735	510	18	275	250	280
ECO 75 G	1450	200	340	885	350	795	530	22	335	300	-

ECO 50, ECO 55 Mechanical Modulation

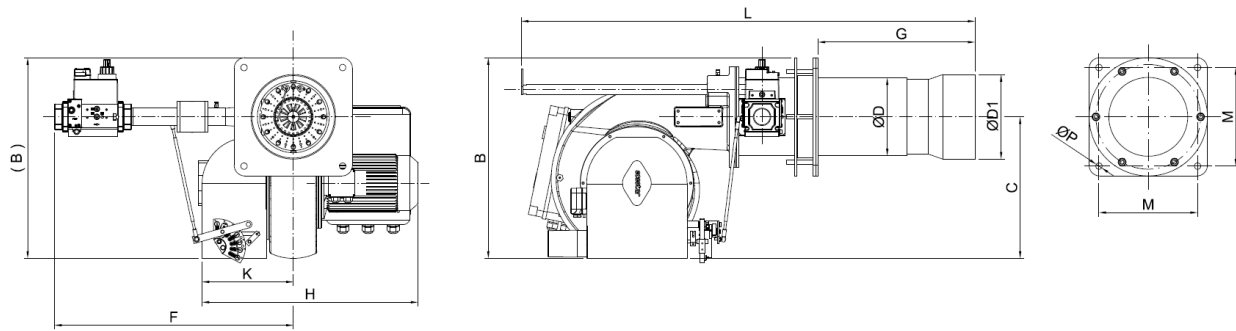

	L	Gmin	Gmax	H	F	K	B	C	ØP	M	ØD	ØD1
ECO 50 G	1300	280	440	650	670	255	570	422	18	275	218	236
ECO 55 G	1300	280	440	650	670	255	570	422	18	275	218	236

* F dimension may vary depending on the valve model.

5.4. Gas Hood Pressure Loss Diagram



Gas hood pressure loss measurements are conducted in atmospheric pressure. Consider the below data while conducting measurement in counter pressure boilers.

P_m : Gas hood pressure while burner is connected to the boiler and working

P_F : Combustion chamber pressure

P_{Br} : Burner net gas hood pressure

$$P_{Br} = P_m - P_F$$

ECO 50

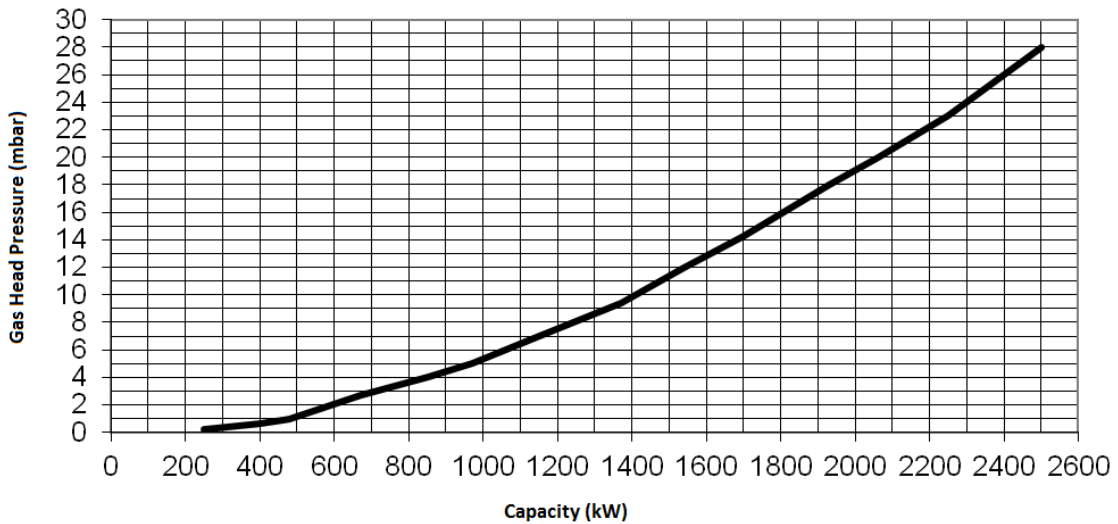

ECO 55

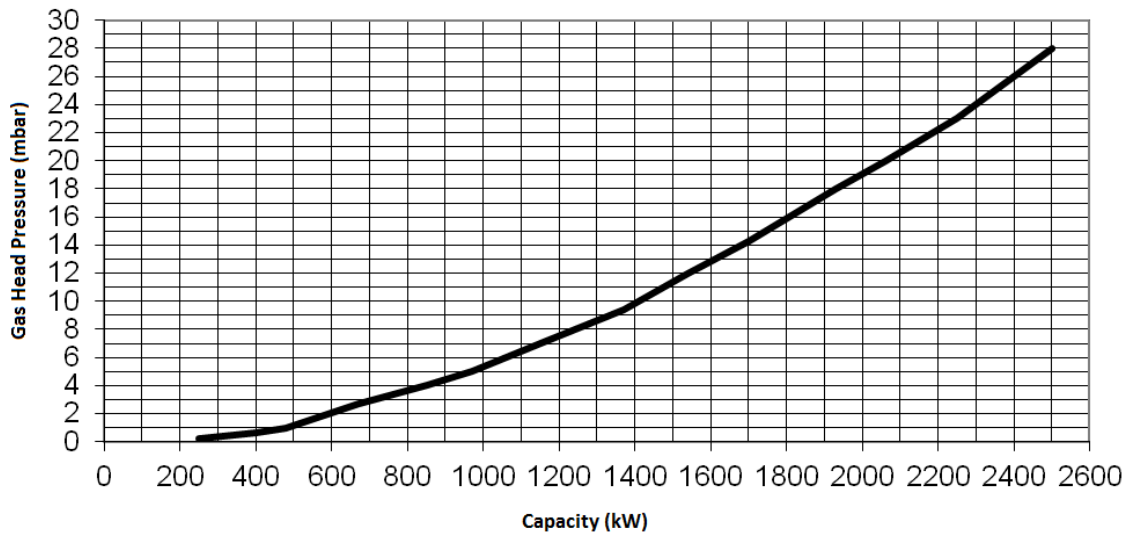

ECO 60

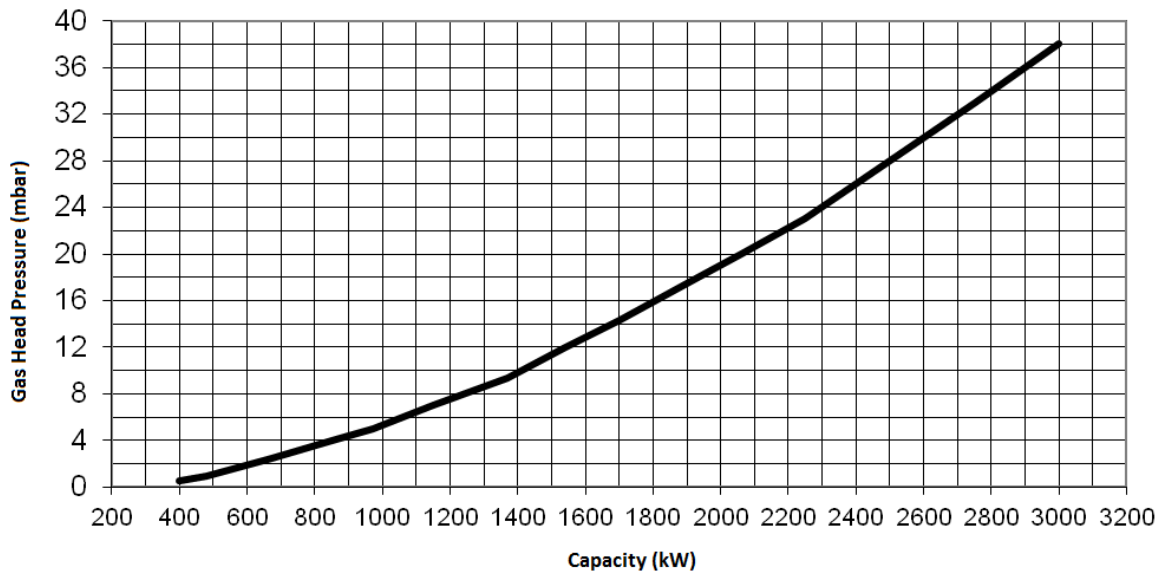

ECO 65

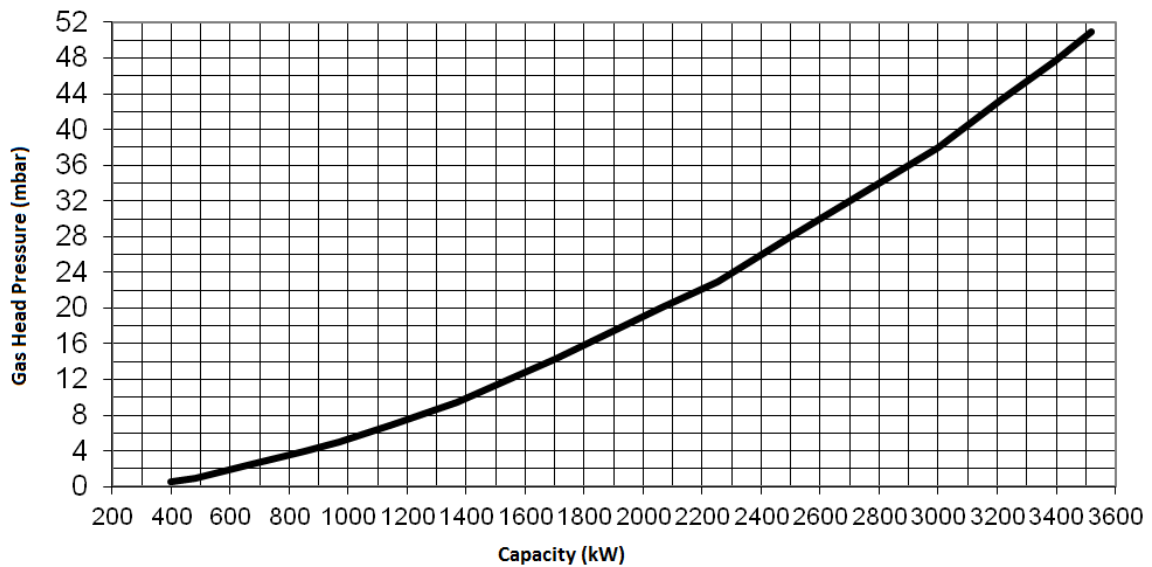

ECO 70

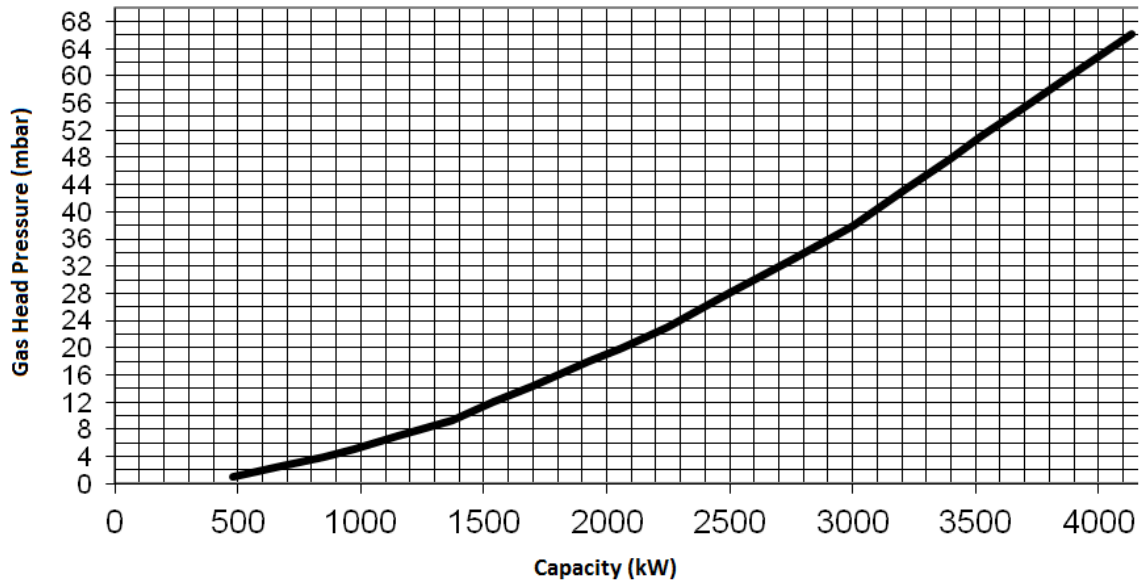

ECO 75

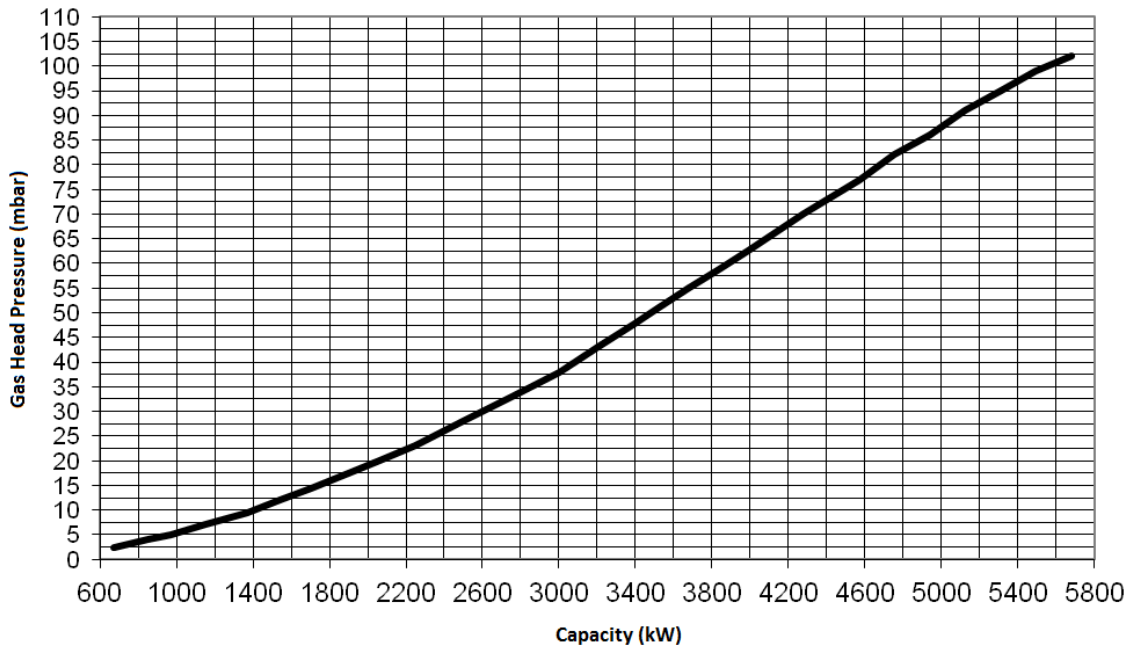

5.5. Flame Length and Diameter

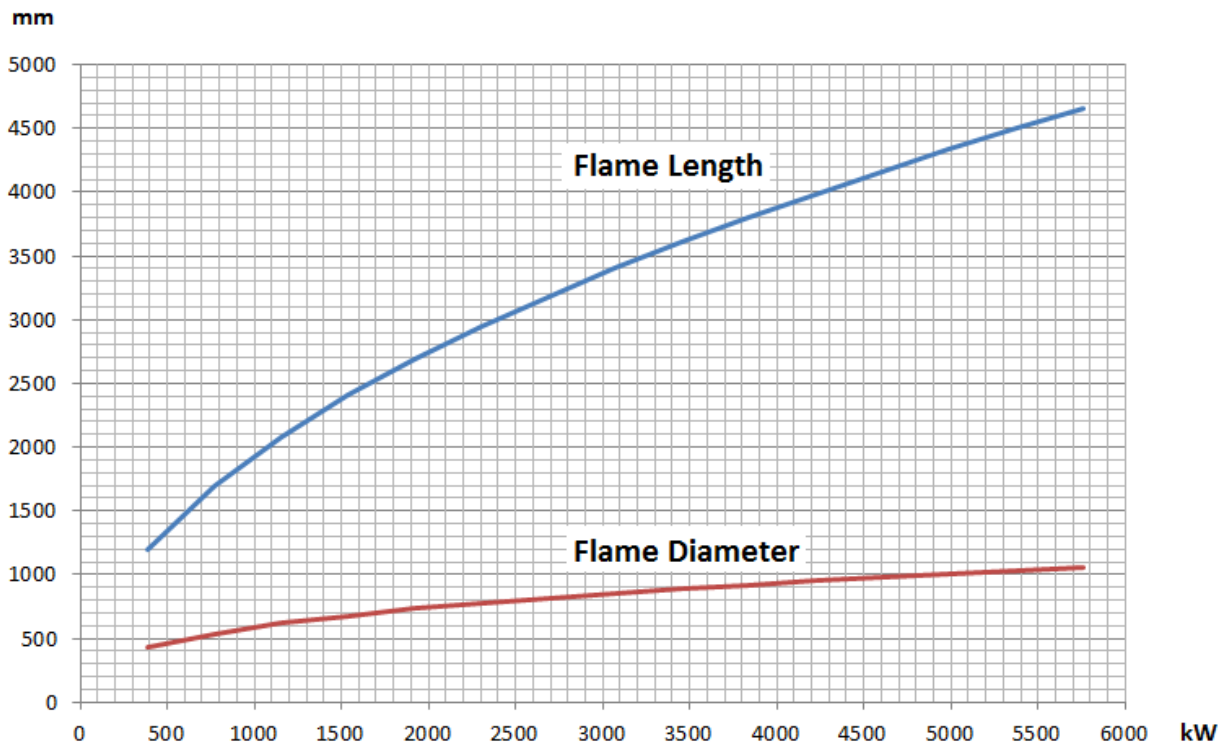

5.6. Noise Level

Product operates within the range of 75 decibels max. and 85 decibels.

6. BURNER HANDLING INFORMATION

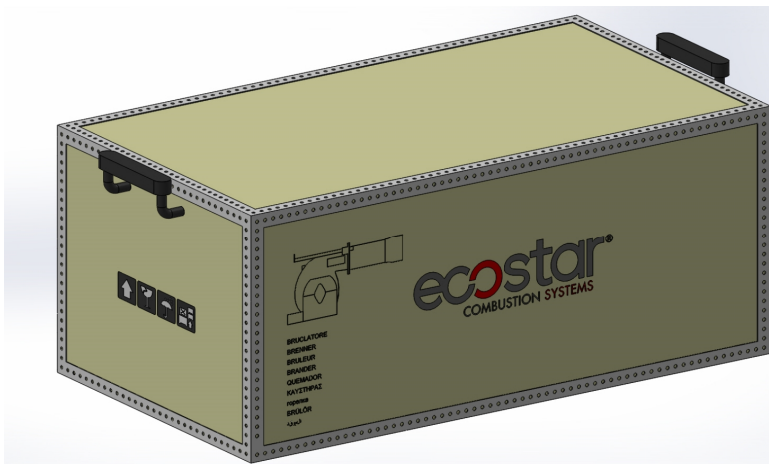

- Lift the product by holding the handles as seen in the picture.
- Prevent strong impacts on top of the product and vibration while handling the product.
- Do not leave the product in wet environment.



Dimensions of the box used for handling

Burner	L x W x H (cm)	Weight (kg)
ECO 50 GC2	133 X 68 X 75	132
ECO 50 GC3	133 X 68 X 75	132
ECO 55 GC2	133 X 68 X 75	132
ECO 55 GC2a	133 X 68 X 75	134
ECO 55 GC3	133 X 68 X 75	134
ECO 55 GC3a	133 X 68 X 75	132
ECO 60 GC2	170 X 90 X 85	196
ECO 60 GC3	170 X 90 X 85	196
ECO 65 GC2	170 X 90 X 85	198
ECO 65 GC3	170 X 90 X 85	198
ECO 70 GC2	171 X 92 X 88	190
ECO 70 GC3	171 X 92 X 88	190
ECO 75 GC3	161 X 102 X 93	286

7. INSTALLATION

7.1. Burner Installation Picture

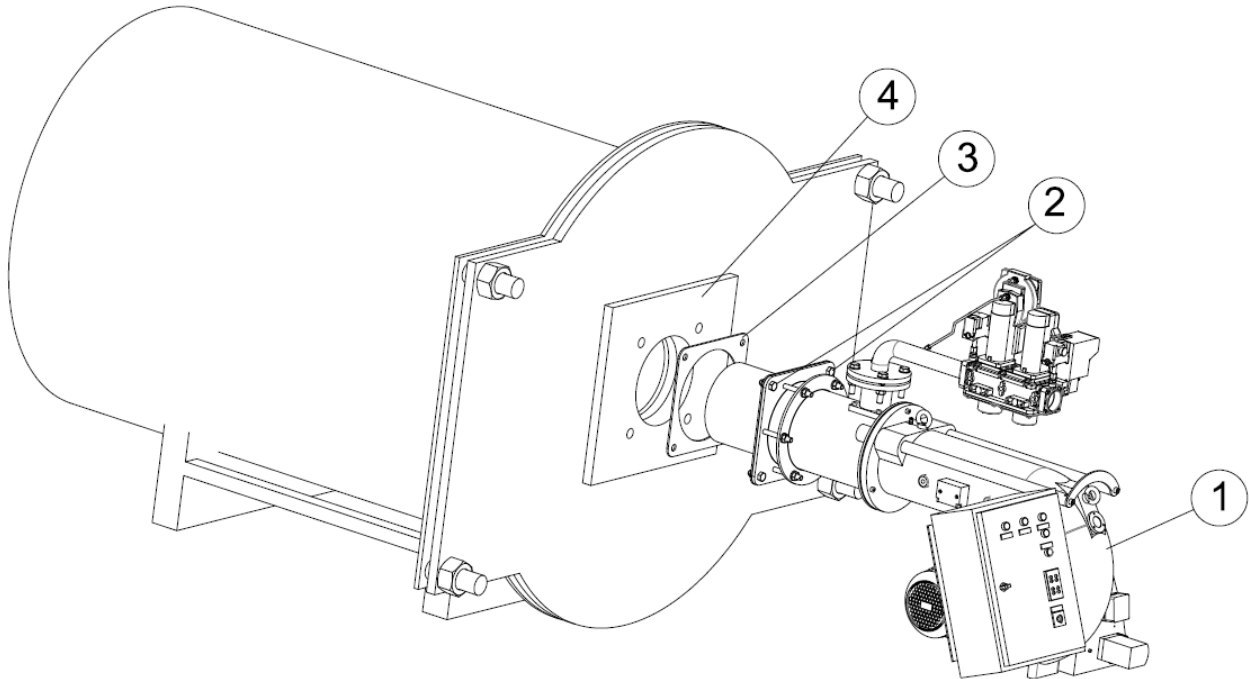

- 1- Burner
- 2- Drift Bolts
- 3- Gasket
- 4- Boiler Flange



You must definitely ensure sealing between boiler and burner!



Device must be shipped in original packaging!



Do not lift the device holding from servomotor, gas valve, impulse pipes or pressure switch during installation!



Clean the inside of fuel line thoroughly before installing the burner to the fuel line. Any damage that may occur due to solid objects and metal particles from the fuel line shall not be covered by our company.

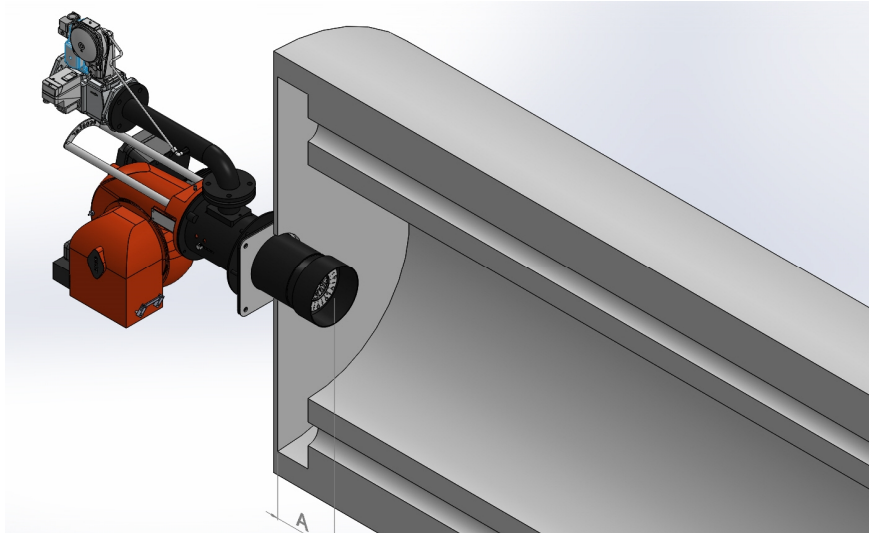

i While installing the burner in reverse flame front mirror boilers, flame tube tip must be adjusted such that it gets inside by 50 mm-100 mm from flue pipes ($50\text{mm} \leq A \leq 100\text{mm}$). Otherwise flue gas temperature will rise and fuel consumption will increase.

8. COMMISSIONING

8.1. Before Commissioning

8.1.1. Ignition and Ionization System

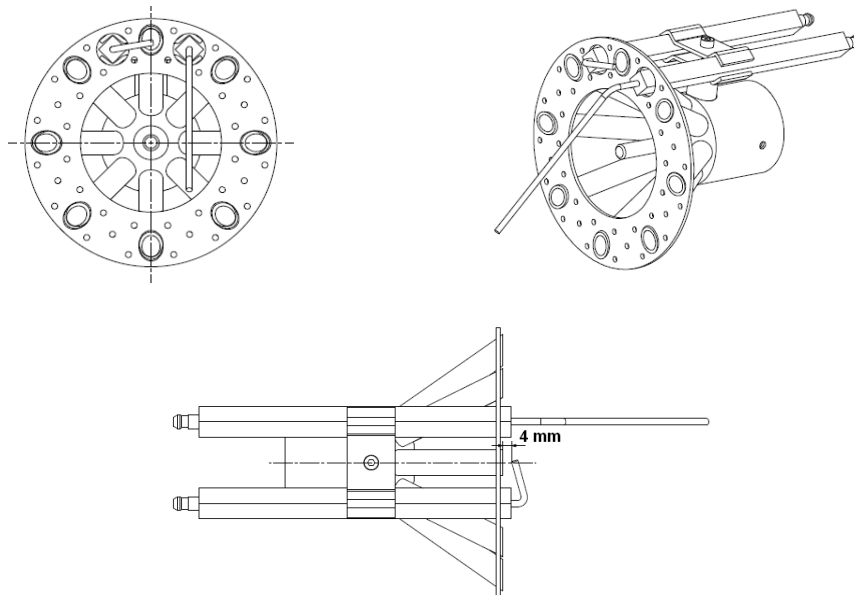

Electrical Connection

Perform electrical connections according to the diagram provided with the burner. Follow general security rules during installation of electric wiring and making connections. Connect the earthing terminal in electric panel to the earthing installation.

8.2. General Controls



Make sure to perform the following controls before commissioning the burner.

- Ø Are the electrical connections correct?
- Ø Is there electricity current?
- Ø Is there gas?
- Ø Has the heating system been filled with water?
- Ø Is the thermostat set at the required temperature?
- Ø Has the boiler explosion lid been controlled?
- Ø Is there sufficient air in boiler room (ventilation section $\text{cm}^2 = \text{boiler capacity kW} \times 7$)
- Ø Has the boiler been installed correctly? Has the boiler cover been closed properly?
- Ø Has the air of the gas line been removed? Has a sealing test been made?

Operation of two-stage burner

- Ø Open the main gas valve, check the gas pressure from the manometer at the valve. (max.300 mbar)
- Ø Check the boiler thermostat or pressure switch settings.
- Ø Bring the operating switch on the burner panel to position 2.
- Ø Burner fan motor will be activated.
- Ø Ignition will take place at the end of pre-purge process.
- Ø 3 sec. later, the gas valve will be opened and combustion will occur.
- Ø Flame control system (ionization) will start flame control.
- Ø Burner will switch to the second stage (max. capacity) according to the heat requirement.
- Ø After the boiler water heated up or the boiler pressure has risen, the burner will turn off.

Operation of a modulating burner

- Ø Open the main gas valve; check max 300 mbar gas pressure from the manometer.
- Ø Open operating switch on the burner panel.
- Ø Switch on the modulating control switch.
- Ø Switch automatic-hand switch to automatic.
- Ø Check the temperature and pressure set values from the modulating control unit.
- Ø Ignition will take place at the end of pre-purge process.
- Ø 3 sec. later, the gas valve will be opened and combustion will occur.
- Ø Flame control system (ionization) will start flame control.
- Ø In modulating burner, the burner goes into max. capacity according to the signal from the modulating control unit.
- Ø When the boiler water temperature or steam pressure increase, the modulating control unit will cause burner to run with min. capacity.
- Ø If the boiler water temperature or steam pressure increases despite the operation of burner with min. capacity, the modulating control unit will stop the burner.

8.3. Combustion Adjustment

8.3.1. Gas Adjustment

Follow the instructions of the valve manufacturer during installation, dismantling and adjustment of the gas valve

8.3.1.1. VGD 20 4011 - 5011 Series Gas Valve

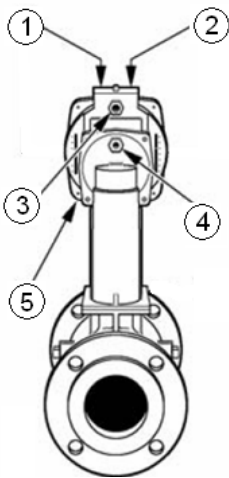

SKP 75 Connection Diagram

- 1 – Air-gas adjustment ratio
- 2 – Zero "0" point (start) adjustment
- 3 – Boiler counter pressure impulse connection
- 4 – Gas pressure impulse connection
- 5 – Air pressure impulse connection

8.3.1.2. MB DLE Series Monoblock Gas Valve

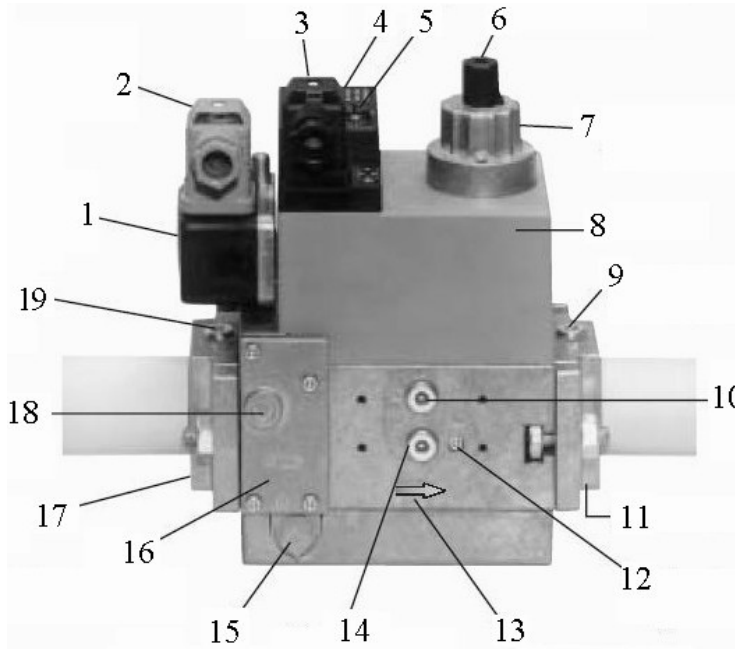

- 1- Pressure switch
- 2- Pressure switch electrical connection
- 3- Electrical connection of the valve
- 4- Operation gauge
- 5- The sealing ring
- 6- Set cover
- 7- Hydraulic disk brakes or settings
- 8- Coil
- 9- Measuring element connection (1/8)
- 10- Measuring element connection (1/8)
- 11- Output flange
- 12- Measuring element connection (1/8)
- 13- Gas flow way
- 14- Measuring element connection (1/8)
- 15- The vent plug
- 16- Filter chamber cover
- 17- Inlet flange
- 18- Measuring element connection (1/8)
- 19- Measuring element connection (1/8)

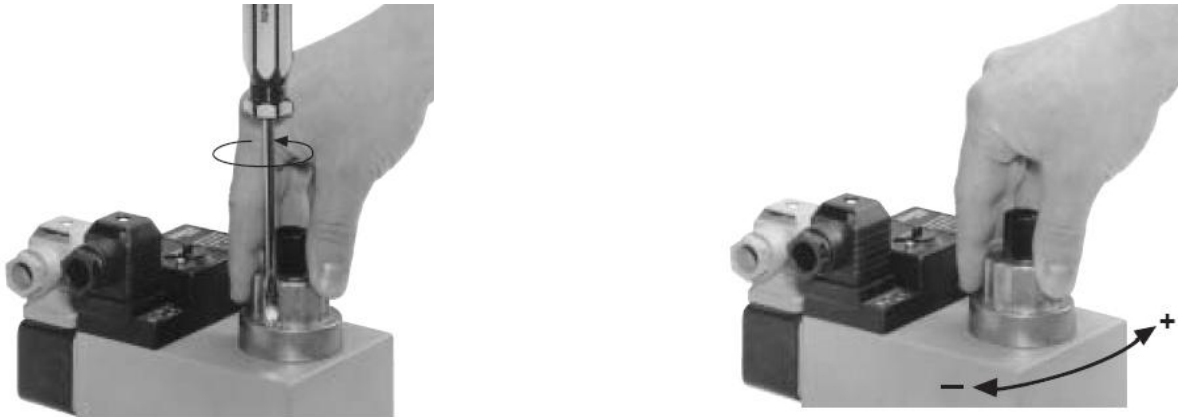

- Consider the below torque values for bolts tightened on the valve.
- Tighten flange bolts according to cross ordering and use proper tools.
- Sealing and function check must be performed if the valve is dismantled and re-installed over the line due to any reason.
- Before dismantling the valve from the line, you can perform filter replacement according to the below order.
 - o Cut off the gas flow (turn off the ball valve)
 - o Remove the 4 bolts (1,2,3,4) on the cover seen in the picture and take out the cover (5).
 - o Take the filter cartridge (6) out of its socket and replace with a new one
 - o Close the cover and tighten the bolts. In frequently performed filter replacement operations, use M4x14 bolt instead of self-tapping bolts used for fixing the cover.
 - o Perform sealing and function control

Max. torque values;

M 4	M 5	M 6	M 8	G 1/8	G 1/4	G 1/2	G 3/4
2,5 Nm	5 Nm	7 Nm	15 Nm	5 Nm	7 Nm	10 Nm	15 Nm

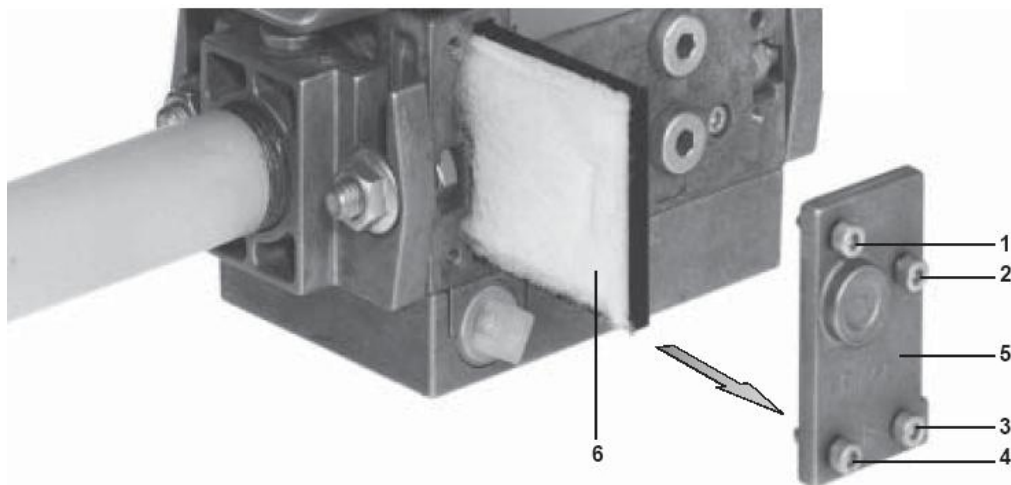

8.3.1.3. MB ZRD(LE) 415 – 420 Series Gas Valve

GasMultiBloc
Combined regulator and
safety shut-off valves
Two-stage function

MB-ZRD(LE) 415 - 420 B01

DUNGS[®]

7.26

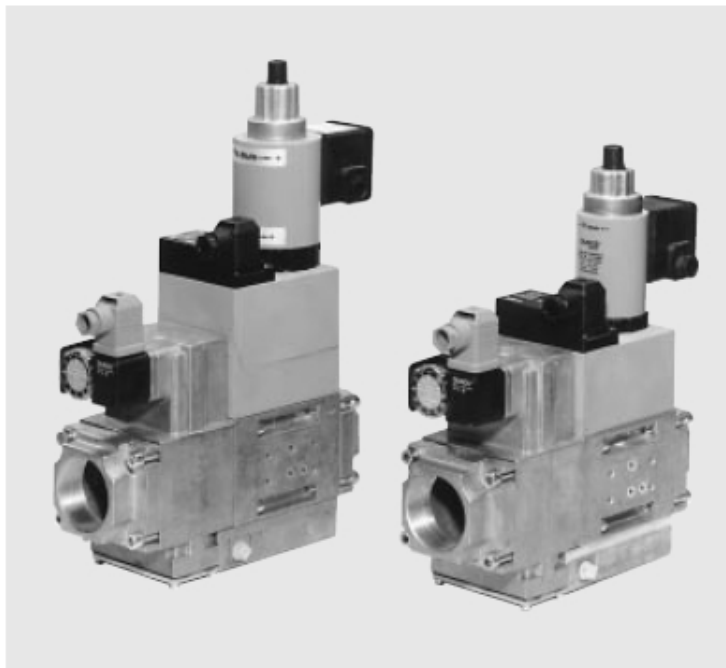

Technical description

The DUNGS GasMultiBloc integrates filter, regulator, valves and pressure switches in one compact fitting. Various designs are possible by the modular system:

- Dirt trap: microfilter
- One regulator and two main valves: B01
- One one-stage valve and one two-stage valve
- One valve is fast opening, one valve is slow or fast opening
- Solenoid valves up to 360 mbar as per DIN EN 161 Class A Group 2
- Sensitive setting of output pressure by proportional regulator as per DIN EN 88 Class A Group 2
- High flow rates with low pressure drop
- DC solenoid drive interference degree N
- Main volume restrictor and partial volume restrictor at valve V2
- Hydraulic opening delay
- Flange connections with pipe threads as per ISO 7/1
- Simple mounting, compact, light-weight

The modular system permits individual solutions by using external ignition gas tap in connection with separately controlled valves, by adding a valve proving system, mini/maxi pressure switches, pressure limiters, limit switch at valve V2.

Application

The modular system permits individual solutions in gas safety and regulator engineering. Suitable for gases of families 1, 2, 3 and other neutral gaseous media.

Approvals

EC type test approval as per EC Gas Appliance Directive:

MB-ZR...415-420 B01 CE-0085 AP 3156

EC type test approval as per EC Pressure Equipment Directive:

MB-ZR...415-420 B01 CE0036

Approvals in other important gas consum-

8.4. Air Pressure Switch Adjustment

While the burner is working without any problem, the air pressure switch is adjusted to desired minimum pressure as follows.

- Ø Unscrew the screw of the transparent cover and remove the cover.
- Ø Turn the adjustment wheel in the direction to increase the pressure, note the pressure value at which the burner is failed.
- Ø Set the pressure switch to a value 1 mbar lower than the pressure value at which the burner failed and close the pressure switch lid.
- Ø It is recommended that this adjustment is carried out when the burner is at minimum load.



8.5. Servomotor Adjustment

The amount of air is adjusted by means of the servomotor. The servomotor adjustment at two-stage and modulating burners is made by the cams on the servomotor.

Ø SQN70

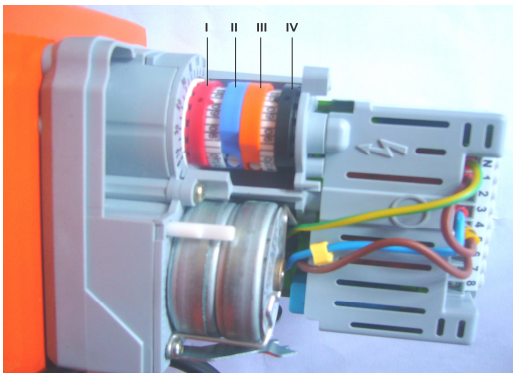

At Two-Stage Burners;

- I. Red Cam: Adjusts 2nd level max. air.
- II. Blue Cam: Resets the clamp.
- III. Orange Cam: Adjusts 1st level min. air.
- IV. Black Cam: Adjusts 2nd level valve opening degree.

At Modulating Burners;

- I. Red Cam: Performance max. air adjustment.
- II. Blue Cam: Resets the clamp.
- III. Orange Cam: Performs min. air adjustment.
- IV. Black Cam: Not used.



Do not open servomotor. Do not interfere with. It may damage servomotor or change burner settings.

8.6. Emission Measurement

In emission measurements, the following values are accepted as reference according to TS EN 676 +A2 standard.

- Ø $CO < 100 \text{ mg/kWh}$
- Ø $\%3 \leq O_2 \leq \%5$
- Ø $NO_x < 170 \text{ mg/kWh}$
- Ø Excess air ratio $1,2 \leq \lambda \leq 1,3$



It is important for the boiler to be sealed in order to avoid incorrect measurements during emission measurements.



Boiler temperature must be between 40 C° and 80 C° while making emission measurement in hot water boilers.

8.7. Capacity Adjustment

Exemplary Application:

Suppose the required burner capacity is (C) 2000 kW.

$H_u = 8250 \text{ kcal/m}^3$ (lower heating value)

$P = 860 \text{ kcal/kW}$ (Value of 1 kW in kcal)

$Q = C \times P$

$Q = 2000 \times 860 = 1720000 \text{ kcal/h}$

$V = Q / H_u$

$V = 1720000 / 8250 = 208.48 \text{ m}^3/\text{h}$

Set the required gas flow rate over the valve and check this value on the gas counter. Should there be no gas flowmeter in the system, set the burner by using the gas tip lost pressure diagram given at page 20-21-22.



In order to ensure the emission values set the air klappe in each gas flow increase.

8.8. Program Relay

LFL 1.32



8.9. Function Controls and Adjustments

- Ø **Operation Testing:** If the burner switch is turned on and safety circuit is complete (gas pressure switch, thermostat, water level gauge, lower pressure gas pressure switch, upper pressure gas pressure switch, gas leakage control device), turn on the ball valve, burner will start working and turn off the gas valve. Program operation of the relay must be normal until ignition time. During opening of the magnetic valve, gas pressure will drop down and the lower pressure switch will stop the burner for safety.
- Ø When the ball valve is opened again, gas pressure will increase and lower pressure switch will trip in from safety position and the burner will automatically start operating.
- Ø Disconnect the ionization circuit or remove the photocell when the burner is operating: Burner will give a fault after burning up.
- Ø Increase the value of the air pressure thermostat: Burner starts operating, however it should give a fault due to the insufficiency of air pressure.



Magnetic valves must not be energized during pre-purge. Check if valves are in closed position!

8.10. Final Checks

- Ø Switch of all purges after completion of all necessary measurements.
- Ø Start and stop the burner at least 3 times to check the operation of the program.
- Ø Make sure that all safety circuits on the burner and boiler operate properly before leaving the installation site.



If the value measure from PL point is below 0.5 bar, set the impulse pipe as follows.

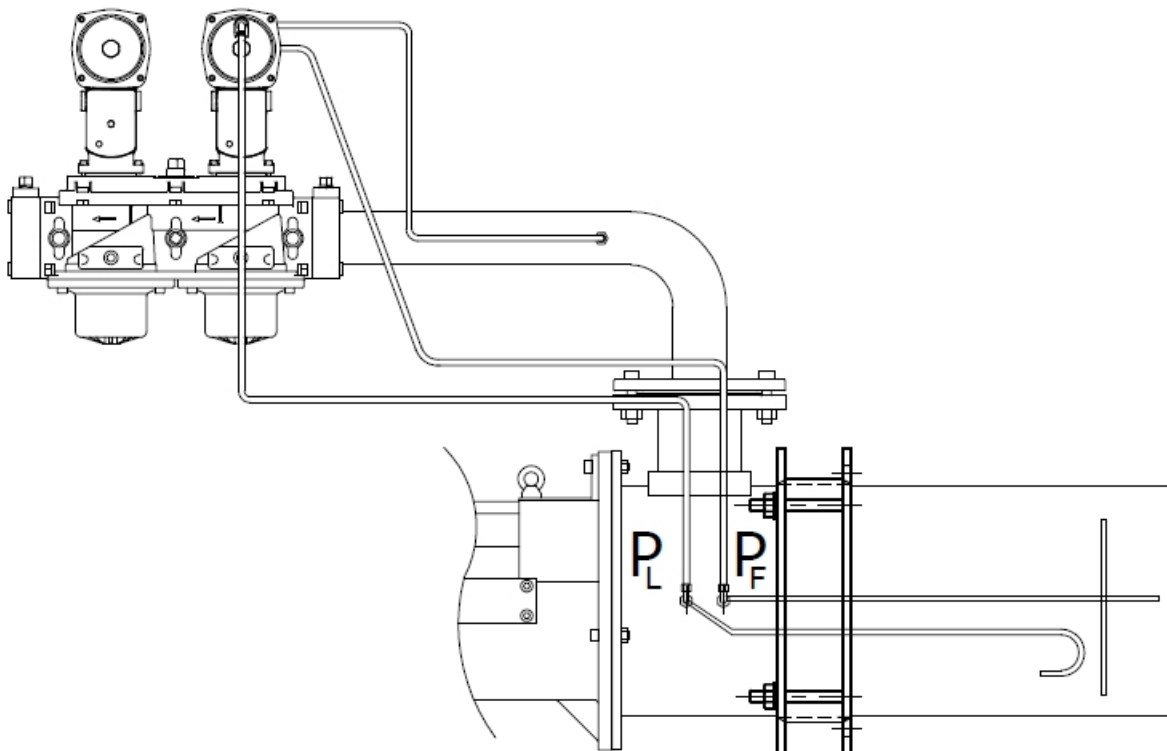
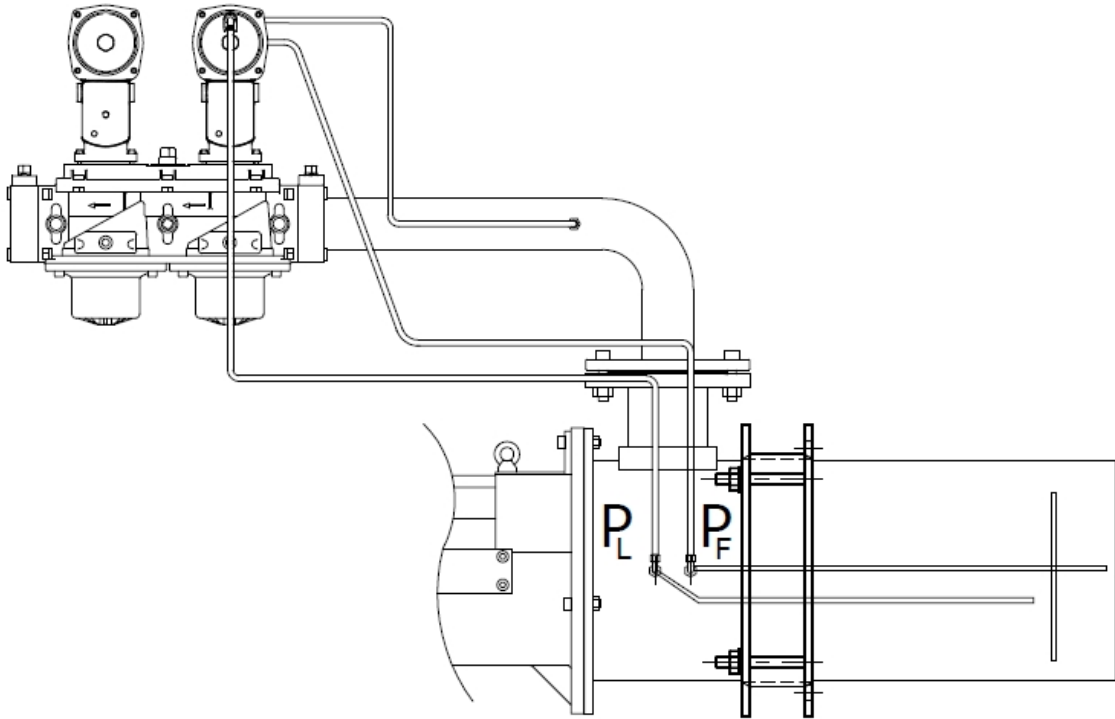



If the flame tube of the burner is longer than standard (standard flame tube length of the burner), please do not forget to support burner body during maintenance and installation/commissioning.

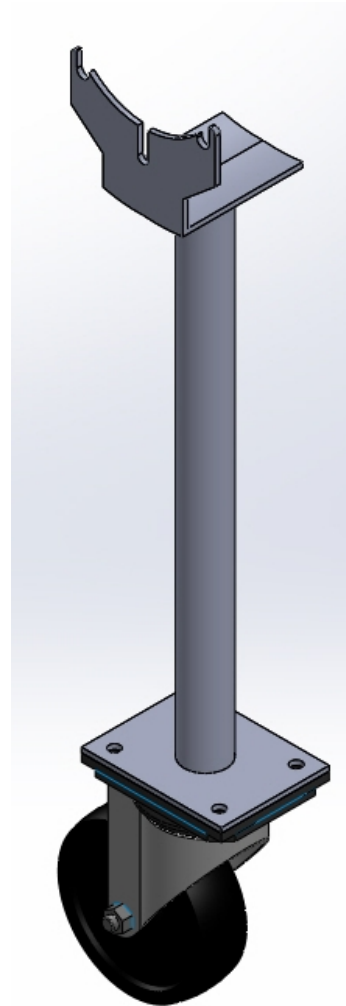
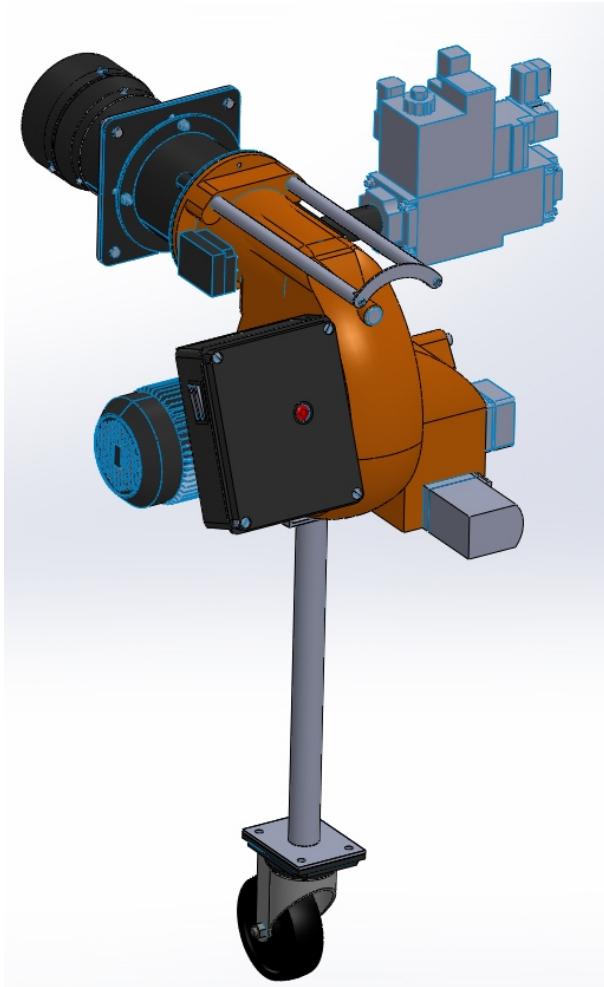

8.11. Gas Pass Equipment Required in Gas Line

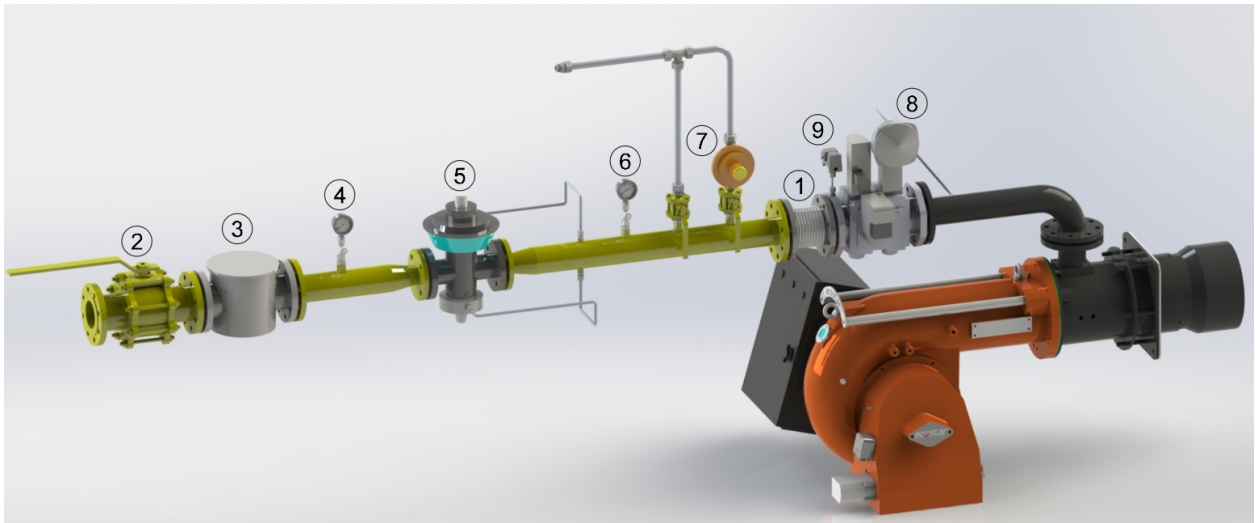

Pe < 300 mbar Q<1200kW	Pe > 300 mbar Q<1200kW	Pe < 300 mbar Q>1200kW	Pe > 300 mbar Q>1200kW
1- Compensator	1- Compensator	1- Compensator	1- Compensator
2- Ball valve	2- Ball valve	2- Ball valve	2- Ball valve
3- Gas filter	3- Gas filter	3- Gas filter	3- Gas filter
4- Inlet manometer + valve	4- Inlet manometer + valve	4- Inlet manometer + valve	4- Inlet manometer + valve
8 – Multi-block (safety and operation solenoids)	5- Regulator	8 – Multi-block (safety and operation solenoids))	5- Regulator
9- Sealing Control Set	6- Outlet manometer + valve	9- Sealing Control Set	6- Outlet manometer + valve
	7- Safety discharge valve		7- Safety discharge valve
	8 – Multi-block (safety and operation solenoids)		8 – Multi-block (safety and operation solenoids)
	9- Sealing Control Set		9- Sealing Control Set



Threaded and flanged connections may vary depending on the gas pressure and consumption.

9. MAINTENANCE

9.1. Monthly Maintenance

Monthly maintenance is a comprehensive process where general checks of burner and peripheral components are performed to prevent possible faults. After completion of maintenance and adjustment processes, make sure to perform an emission analysis.

- Ø Clean the filters on the main line and multiblock.
- Ø Check the burner gas tip.
- Ø Perform insulation measurements of ignition and ionization electrodes, replace electrodes should there be leakage to the body.
- Ø Check ignition cables and sockets.
- Ø Check all wiring points. Tighten loose connections.
- Ø Clean the dust and layers accumulated on the fan and air klappes.
- Ø Check gas line pressure, it must be the same with the first adjusted pressure, otherwise burner load and emission values will also have changed.
- Ø Check all bolts of the burner. Tighten loose bolts.
- Ø After starting the burner and adjusting air klappe, perform flue gas emission measurement and check if there is an ideal combustion.

9.2. Seasonal Maintenance

Comprehensive maintenance work when the burner is re-started after long periods of shut-down or interruptions. After completion of maintenance and adjustment processes, make sure to perform a combustion analysis.

- Ø Check insulation resistance of electric motor.
- Ø Replace ignition and ionization electrodes with new ones.
- Ø Clean air fan and clamps.
- Ø Check the operating function.
- Ø Check boiler thermostats.
- Ø Check cleanliness of boiler inside and clean if necessary.



Follow installation directions during maintenance.

9.3. Installation And Disassembly Instructions For Maintenance Purposes

ECO 50, ECO 55

For Intervention to Ignition System

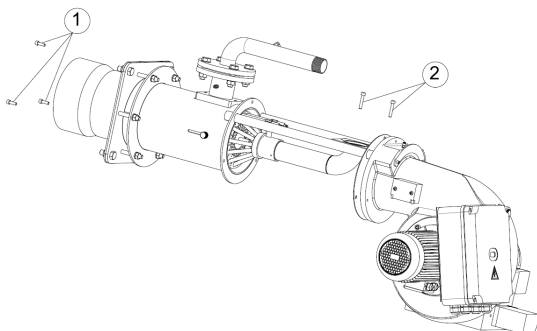

- Ø Remove 3 bolts number 1 that connect the body group and gas tip, and pull back the body group.
- Ø Remove bolts number 2 from the gas tip and interfere the ignition system.

For Intervention to Fan and Motor:

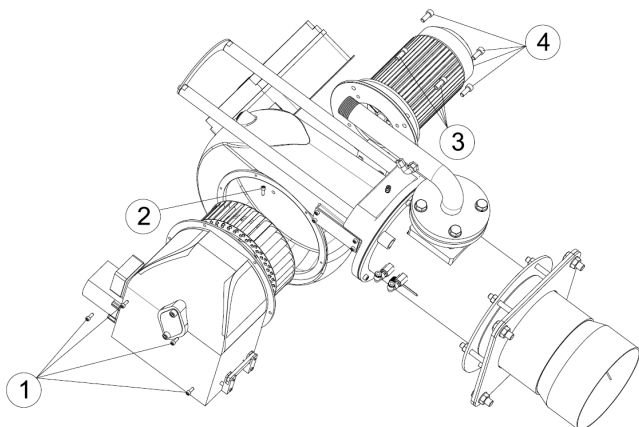

- Ø Remove the bolts number 1 from the air vent and take the air vent back.
- Ø Remove the bolt number 2 making the fan-motor connection and detach the fan from the motor.
- Ø Remove the bolts number 3 connecting the motor flange and the body group. Detach the motor from the body.
- Ø Remove the motor-flange bolts number 4 and interfere the motor group.

For Intervention to the Air Klappe:

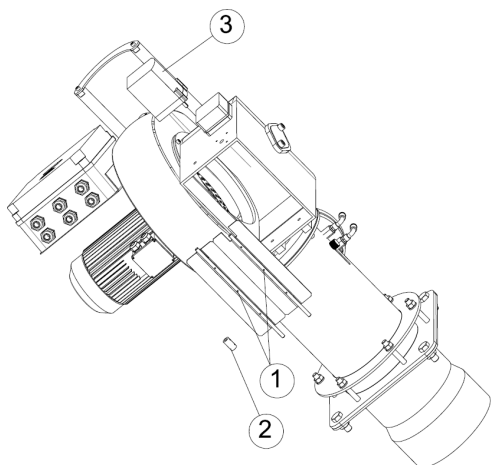

- Ø Remove the bolts number 1 on the air klappe.
- Ø Remove the bushing number 2 on servomotor - air klappe group.
- Ø Remove the servomotor number 3 from the air vent.

ECO 60, ECO 65, ECO 70

For Intervention to Ignition System

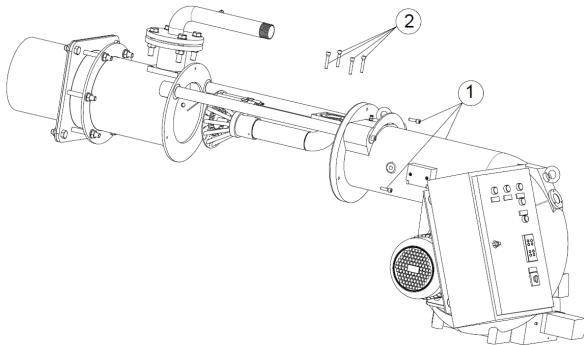

- Ø Remove 3 bolts number 1 that connect the body group and gas tip, and pull back the body group.
- Ø Remove bolts number 2 from the gas tip and interfere the ignition system.

For Intervention to Fan and Motor:

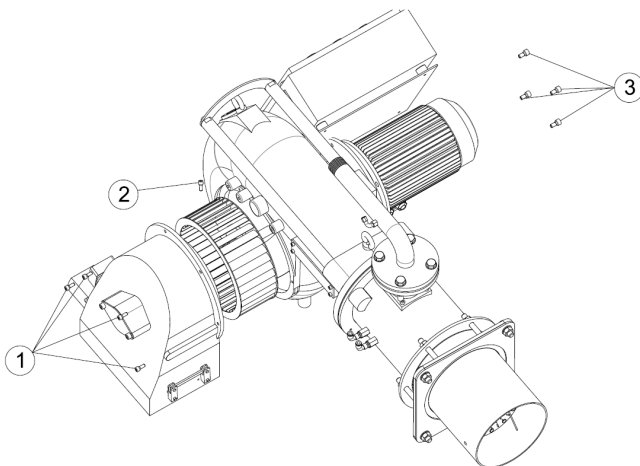

- Ø Remove the bolts number 1 from the air vent and take the air vent back.
- Ø Remove the bolt number 2 making the fan-motor connection and detach the fan from the motor.
- Ø Remove the bolts number 3 connecting the motor flange and the body group. Detach the motor from the body.

For Intervention to the Air Klappe:

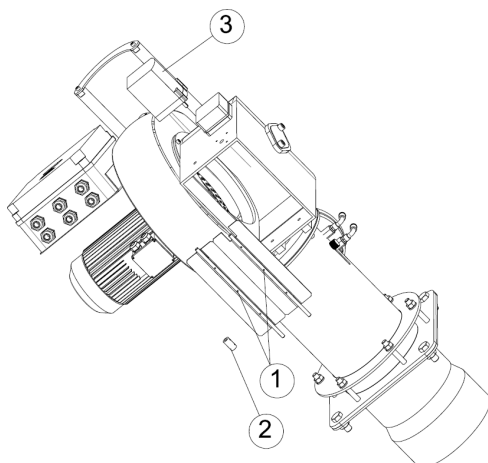

- Ø Remove the bolts number 1 on the air klappe.
- Ø Remove the bushing number 2 on servomotor - air klappe group.
- Ø Remove the servomotor number 3 from the air vent.

ECO 75

For Intervention to Ignition System

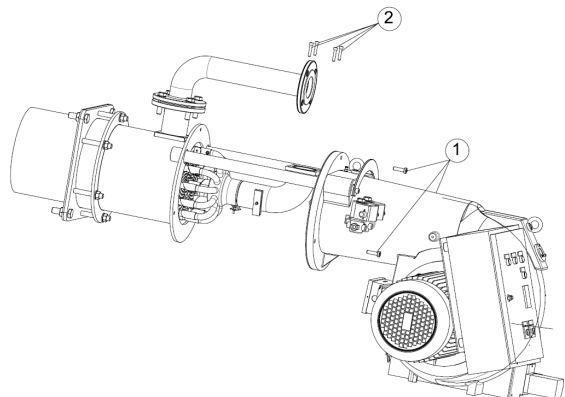

- Ø Remove 3 bolts number 1 that connect the body group and gas tip, and pull back the body group.
- Ø Remove bolts number 2 from the gas tip and interfere the ignition system.

For Intervention to Fan and Motor:

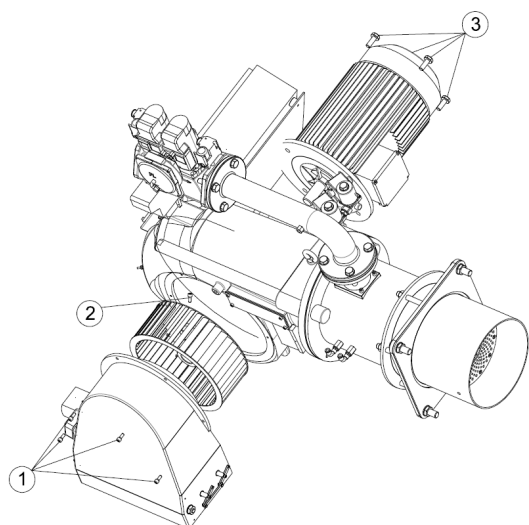

- Ø Remove the bolts number 1 from the air vent and take the air vent back.
- Ø Remove the bolt number 2 making the fan-motor connection and detach the fan from the motor.
- Ø Remove the bolts number 3 connecting the motor flange and the body group. Detach the motor from the body.

For Intervention to the Air Klappe:

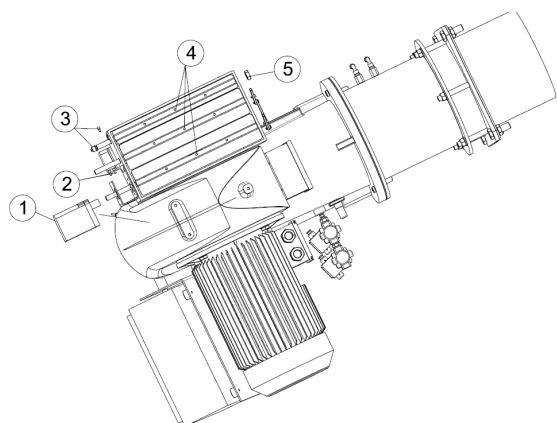

- Ø Remove the servomotor number 1 from the air vent and take out the servomotor.
- Ø Remove the bushing number 2 from the servomotor.
- Ø Remove the bolt number 3 from the air klappe.
- Ø Remove bolts number 4 and remove the air klappe from the servomotor drive shaft.
- Ø Remove the bolt number 5 and interfere the air klappe.

10. TROUBLESHOOTING

Problem	Cause	Explanation-Suggestion
Burner cannot be commissioned	Gas is cut or does not come	Gas valve might be closed. Open the valve.
	Fuse failure	Check burner power supply. The fuse on the main panel or the fuse on the burner might be tripped.
	Relay failure	Reset the thermal relay. Check adjustment of the thermal relay according to the current in motor label. If the failure is not removed, replace the thermal relay.
	Boiler thermostat, pressure switch failure	If there is a problem with the burner thermostats, pressure switches and steam tank this may be due to an unadjusted or faulty water level device; adjust it and if broken, replace it.
Flame appears and goes into failure mode.	Gas pressure error	Supply gas pressure might be low.
	Ionization electrode failure	Ionization electrode may be faulty or contaminated. Remove and clean.
	Program relay failure	Replace it with a new one.
Burner starts up, but fails after 10 seconds.	Air pressure switch adjustment	Air pressure switch might be adjusted to a high value. There may be dirt in the air pressure switch. Air pressure switch might be broken.
	Program relay failure	Replace it with a new one.
	Fan motor failure	Check fan motor coils, motor contactor and outlet from program relay.
Burner starts up, but fails after 30 seconds.	Gas valve, gas pressure drop	Gas valve might be closed. Supply gas pressure might be low. Check gas inlet manometer.
	Ignition electrode failure	Ignition electrodes might be misadjusted or ignition cables might have come out of their terminals. Adjust ignition electrodes with a distance of 3-5 mm. between them.
	Gas valve adjustment	Check the starting setting of the gas valve. Burner must be adjusted to sufficient start gas flow for its activation.
Boiler cover is overheating.	Sealing problem	Ensure sealing between the boiler cover and burner. If required, use insulating material between the boiler connecting flange and boiler cover.

11. PERIODICAL FLUE GAS MEASUREMENT REPORT

Fuel Consumption (m ³ /h)	CO (ppm)	O ₂ (%)	CO ₂ (ppm)	NO _x (ppm)	Yield (%)	Flue Temp. (°C)	Date	Signature

12. AFTER-SALES SERVICES

Dear Customer,

We believe that providing a good service is as important as providing a good product. Therefore, we continue offering wide range of comprehensive services to our conscious customers.

Our contact details for your requests and complaints

Esentepe Mah.Milangaz Cad. No:75 K:3

Kartal Monumento Plaza

KARTAL/İSTANBUL/TÜRKİYE

Tel: +90 216 442 93 00

Fax: +90 216 370 45 03

Factory Contact Details

Türkgücü OSB

Bülent Ecevit Bulvarı No:11

ÇORLU/TEKİRDAĞ/TÜRKİYE

Tel: +90 282 685 44 80-81

Fax: +90 282 685 42 09

Also you can contact with us:

Web site : www.ecostar.com.tr

E - mail : servis@ecostar.com.tr



Please observe the following recommendations.

- Use the product in accordance with the principles of this manual.
- For any service demands regarding the product, please contact our Service Center from the abovementioned phone numbers.
- Upon your purchase, register your warranty certificate during installation.

