

# **ECO WO MULTI OIL BURNERS INSTALLATION, OPERATING AND MAINTENANCE INSTRUCTIONS**

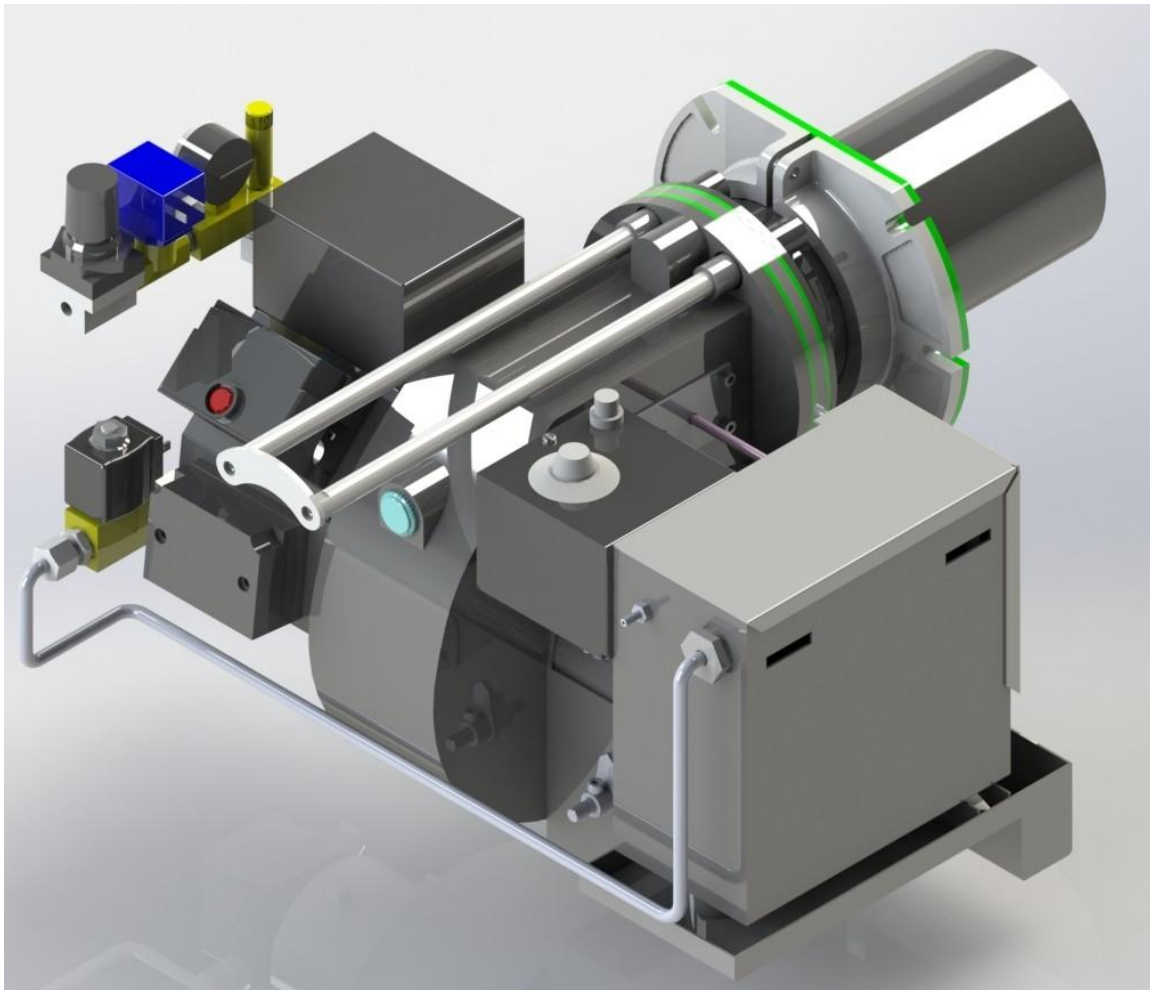

**ECO WO-20  
ECO WO-55  
ECO WO-75  
ECO WO-100  
ECO WO-150  
ECO WO-200**

**DEAR USER,**

**ECO WO-20, ECO WO-55, ECO WO-75, ECO WO-100, ECO WO-150, ECO WO-200**, multi oil burners are prepared and manufactured in line with the latest technical inventions and safety rules. It is easy to use for our customers.

We recommend that you read this manual and safety warnings thoroughly before the use of the device in order to ensure safe, cost effective and environmental-friendly use.

If you encounter any issue that is not explained clearly in this manual or you could not understand, please contact with our service department.

We thank you for choosing **ECOSTAR** brand.

This Operating Manual is an integral part of the burner and must be maintained in a plastic dossier and hung at a clearly visible place in the burner room.



**TERMO ISI SİSTEMLERİ SAN.VE TİC.A.Ş.**

Çağla Plaza, Atakent, Mithatpaşa Cd.

No:116, 34760 Ümraniye/İstanbul

Tel: +90 216 442 93 00

Fax: +90 216 370 45 03

[www.ecostar.com.tr](http://www.ecostar.com.tr)





[e-mail:servis@ecostar.com.tr](mailto:servis@ecostar.com.tr)

## CONTENTS

1. WARNINGS.....	3
1.1. Warning Symbols and Descriptions .....	3
1.1. General Safety Rules .....	4
BURNER ROOM .....	5
2. TERMS OF WARRANTY .....	6
2.1. Out of Warranty Conditions .....	6
3. BURNER’S GENERAL FEATURES .....	7
4. TECHNICAL DATA .....	8
4.1. Capacity and Technical Chart .....	8
4.2. Capacity Diagrams.....	9
4.3. Oil Consumption – Primary Air Pressure.....	11
4.4. Burner Components .....	12
4.5. Outer Dimensions .....	17
4.6. Noise Level.....	17
4.7. Basic Settings.....	18
4.8. Function Description.....	18
5. REGULATIONS .....	20
5.1. Primary air regulator .....	20
5.2. Secondary air regulator.....	20
6. ATTENTION PLEASE - A SUMMARY OF IMPORTANT POINTS REGARDING “ECO WO” .	21
7. INSTALLATION & COMMISSIONING .....	22
7.1. Setting Into Operation.....	22
7.2. Flame Ring And Ignition Electrode .....	23
8. TROUBLESHOOTING.....	24
9. ELECTRICAL DIAGRAM .....	25
10. PERIODICAL FLUE GAS MEASUREMENT REPORT .....	26
11. AFTER SALES SERVICES .....	27
12. NOTES.....	28

## 1. WARNINGS

### 1.1. Warning Symbols and Descriptions

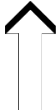
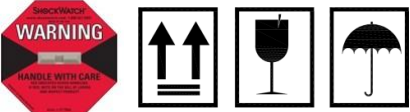
Symbols	Symbol Descriptions
	Important information and useful hints.
	Warning of danger to life or property.
	Warning of electrical voltage.
	Product handling information.
	Electric motor direction of rotation
	Carry in an upright position. Fragile Item. Protect against water.

## 1.1. General Safety Rules

- All personnel engaged in installation, disassembly, commissioning, operation, control, maintenance and repair should have received the necessary training and fully read and understood this manual.
- No changes that might damage the safety of the burner unit must be made by persons and/or organizations on the burner unit.
- All operation, commissioning and installation works (except for burning adjustment) should be carried out when the burner is not operating and after disconnecting the power supply. Noncompliance with these rules may lead to serious bodily injuries and even death by electrical shocks or uncontrolled flame formation.
- Repairs concerned with safety elements should be carried out only by the manufacturing company.
- The device should never be used by children, mentally handicapped and inexperienced persons.
- Children must not be allowed to play with the device.
- Keep the device away from explosive and flammable materials.
- Device must intake air, ventilation and air discharge holes must not be closed.



Do not store any inflammable materials in boiler room.



Wear hearing protectors if there is noise in boiler room.



**In case of fire or other emergency;**

- Switch off the main switch
- Take appropriate actions



The burner installation must be carried out in accordance with the instructions. Vibration can damage the burner and its components.



Keep boiler doors closed while starting burner and during burner operation.



Check combustion values to be correct by using flue gas analyzer at the whole adjustment range between minimum, full load, and ignition load.



Use lifting device or belt for lifting fan motor, if necessary.



During the first commissioning of the burner or in case of any revision carried out in the electrical system or motor cables by any reason, direction of the fan rotation must certainly be checked by the authorized technical service.



For products that have not been commissioned or started more than 6 months, before activating the servomotor;

In air dampers and oil regulators, servomotor and air damper connections must be checked to ensure that they are free running in spite of immobility and oil freezing.



## **BURNER ROOM**

Install the burner in a suitable room/floor with minimum external air openings and sufficient to ensure perfect combustion, in compliance with current regulations.

Never obstruct air openings of the burner room, burner fan intake vents or air ducts in order to prevent:

- a. The build up of toxic / explosive gas mixtures in the burner room,
- b. Combustion with insufficient air, resulting in hazardous, anti-economical and polluting operation.

The burner must be always protected from rain, snow and frost to prevent corrosion and paint deformations.

Keep the burner room clean and free of solid volatile substances, which could be sucked into the fan and clog the internal burner or combustion head air ducts.

## 2. TERMS OF WARRANTY

Main and auxiliary equipment and all components used in Ecostar light oil burners are guaranteed for 1 year by TERMO ISI SİST. A.Ş starting from the date of commissioning under the maintenance, adjustment, operating conditions and relevant mechanic, chemical and thermal effects explained herein.



Please note that this warranty is only valid if the device(s) is commissioned and maintained by our authorized services.



Our company reserves the right to make any modifications on the product and all instructions thereof for improvement purposes.

### 2.1. Out of Warranty Conditions

- Any damage arising out of or in relation to customers' non-compliance to their responsibilities with regards to installation, commissioning, operation and maintenance,
- Any damage arising out of or in relation to commissioning, repairs and maintenance carried out by unauthorized services,
- Any damage that may occur during transportation or storage of the product,
- Not preserving the product in its original packaging until the installation stage,
- Incorrect and poor electrical connections, Failures due to incorrect voltage applications, frequent repetition of voltage fluctuations,
- Any damage that may occur as a result of incorrect fuel usage or, foreign substances in the fuel used or using of the product without any fuel,
- Any damage that may occur due to foreign particles entered into the product during installation and operation,
- Failures due to incorrect device selection,
- Any damage to unit due to natural disasters,
- Devices without any warranty certificates,
- Warranty Certificates without the stamp and signature of the authorized dealer or service,
- Devices with any falsification on the warranty certificate or without an original serial number.
- The risks during transportation of device under the responsibility of customer belong to the customer.
- Presence of misuse faults are indicated in the reports issued by authorized service stations or our authorized agent, dealer, representative or our factory in case of unavailability of authorized service stations.
- Customers may apply consumer protection arbitrator committee with regards to this report and request for an expert report.

### 3. BURNER'S GENERAL FEATURES

**ECOSTAR** multi oil burners are used in motor workshops, garages, etc. to burn black oil, diesel, waste oil as well as plant oil and similar fuel types.

The burners are designed to be used for; closed hot water central heating systems, central hot water generation, industrial process heat, warm air generators.

**ECOSTAR** multi oil burner use fuels as: domestic oil, vegetable oil, waste oil or mixtures without alteration of burner, primary regulation, only adjustment per air regulator and oil temperature regulator.

Each part is easily accessible, which provides easy maintenance and cleaning. All burners are equipped with electronic control equipment (thermostats, manometers, valves, etc.) to reliably control fuel burning.



Collect and store your oil continuously according valid regulations.



When using waste oil, water and sludge are not combustible!

This device must never not be operated with open flame!



#### 4. TECHNICAL DATA

##### 4.1. Capacity and Technical Chart

BURNER TYPE	OIL CONSUMPTION		BURNER CAPACITY		FAN MOTOR POWER	VOLTAGE AT 50 Hz	OIL HEATER	WEIGHT
	Min. Kg/h	Max. Kg/h	Min. kW	Max. kW	kW	V	kW	Kg

<b>ECO WO-20</b>	2,5	3,9	26	38	0,11	220-380	1	20
<b>ECO WO-55</b>	3,6	5,2	37	54	0,11	220-380	1	20
<b>ECO WO-75</b>	5,4	7,8	56	81	0,15	220-380	1	26
<b>ECO WO-100</b>	7,8	9,6	81	100	0,15	220-380	1	26
<b>ECO WO-150</b>	8,9	14,1	93	147	0,15	220-380	1	26
<b>ECO WO-200</b>	12,7	18	131	187	0,15	220-380	1	26

## 4.2. Capacity Diagrams

### ECO WO-20

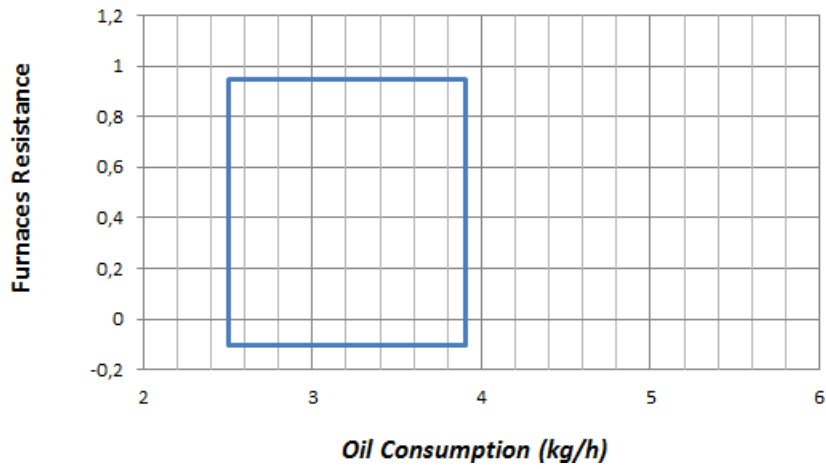

### ECO WO-55

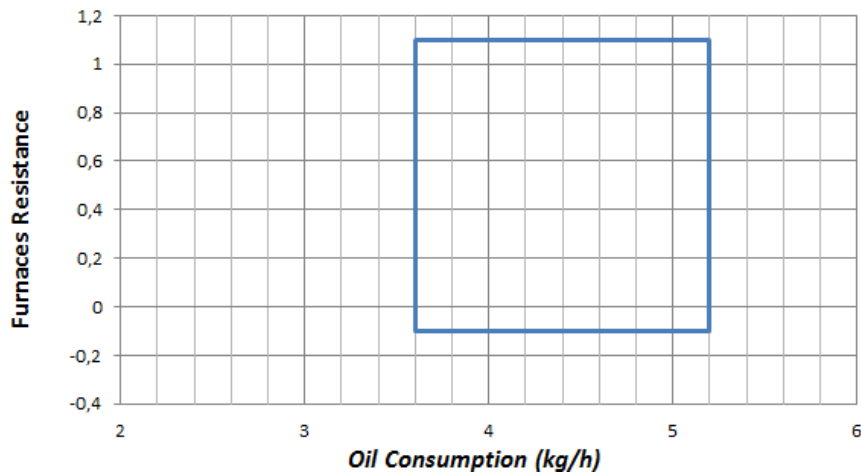

### ECO WO-70

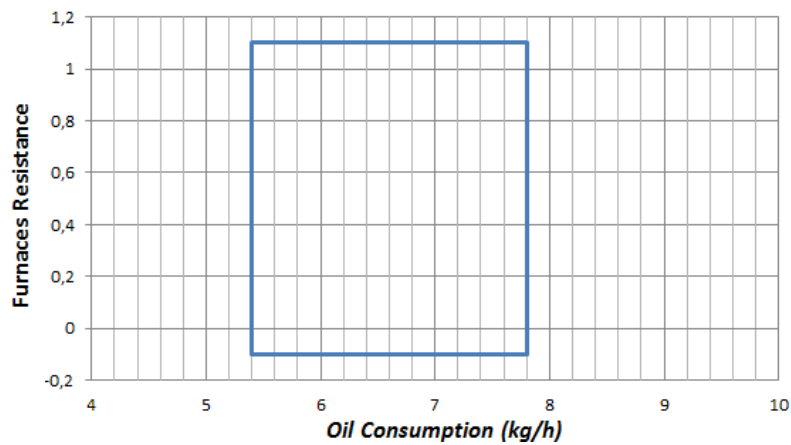

### ECO WO-100

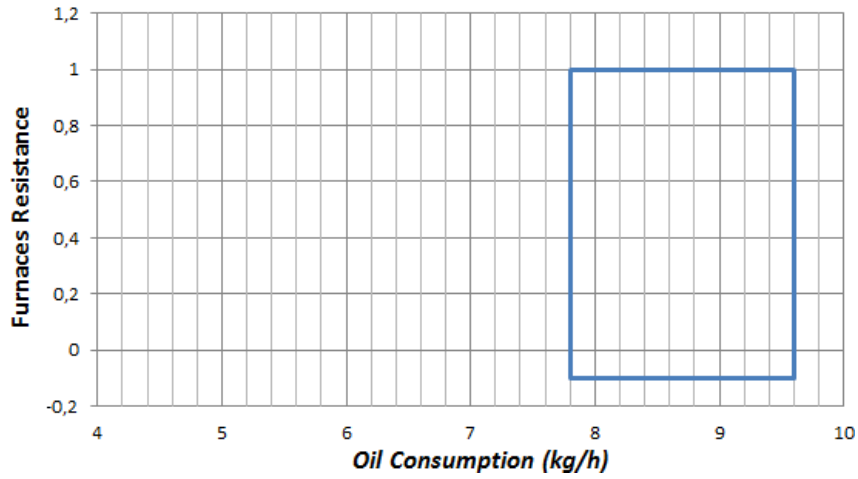

### ECO WO-150

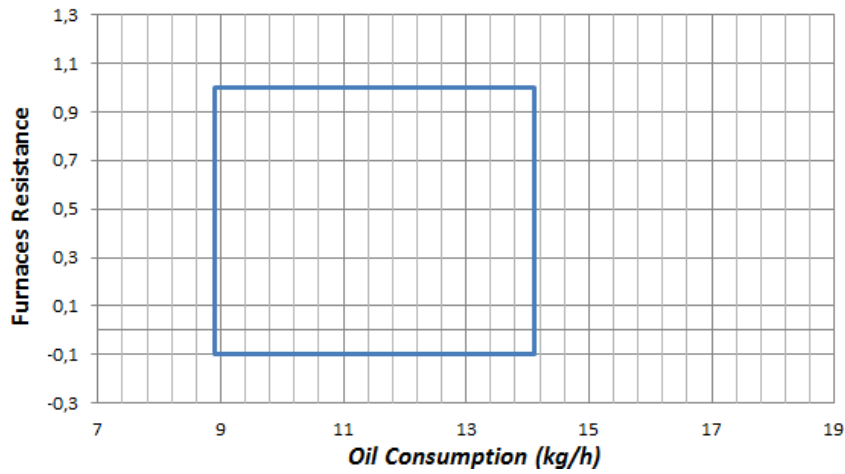

### ECO WO-200

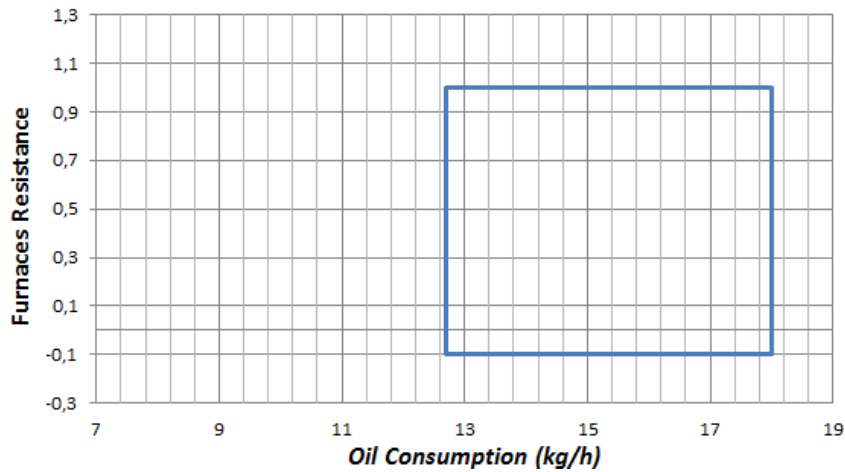

4.3. Oil Consumption – Primary Air Pressure

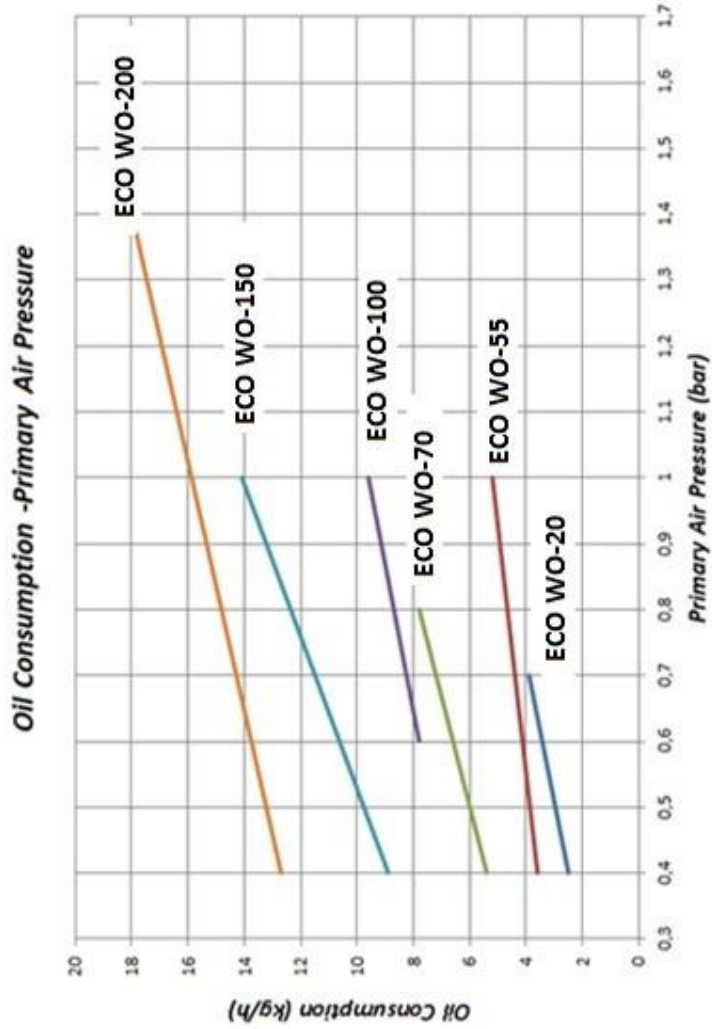

#### 4.4. Burner Components

ECO WO-20/55

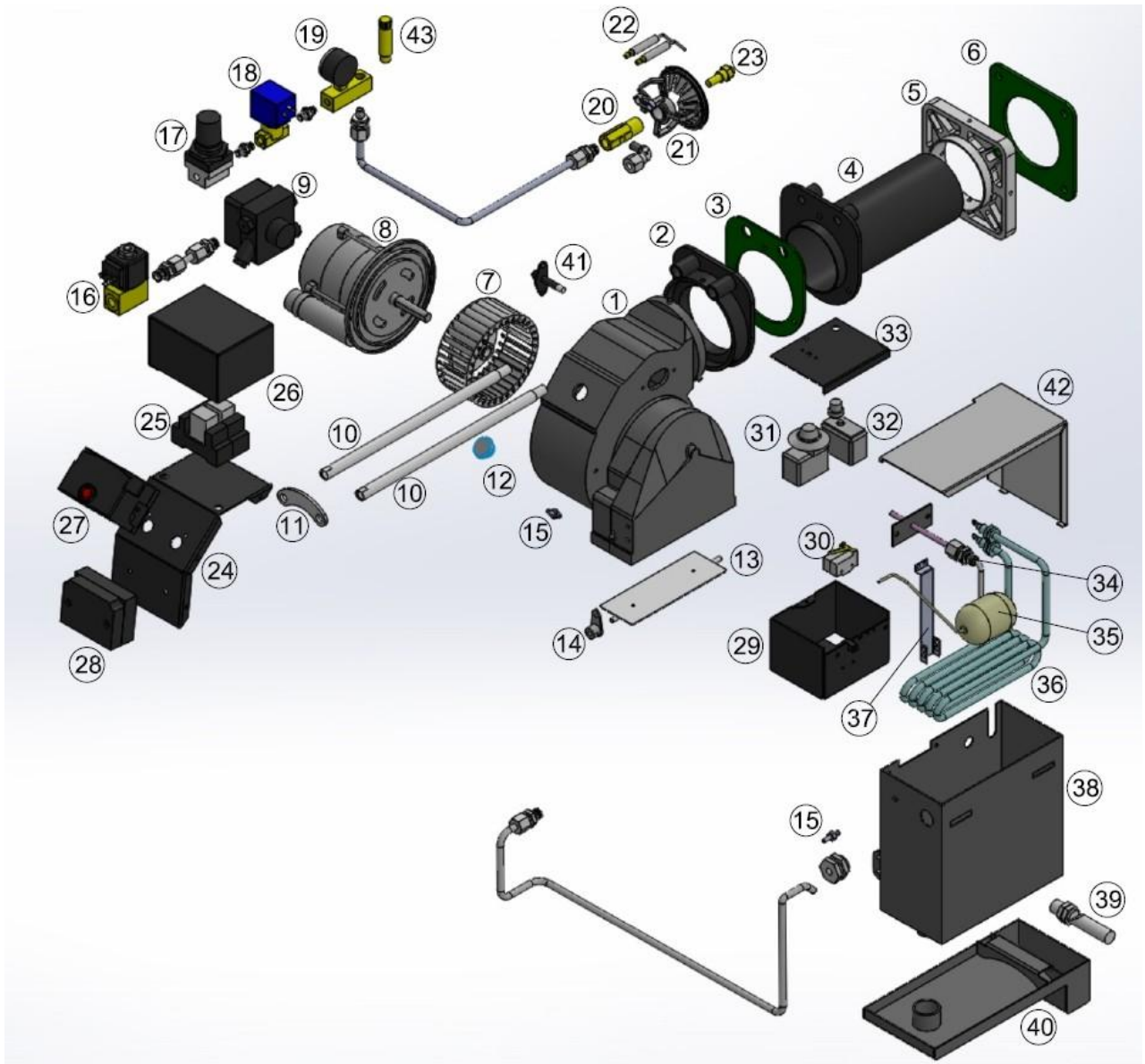

<b>ECO WO-20/55</b>			
<b>No</b>	<b>Name</b>	<b>No</b>	<b>Name</b>
<b>1</b>	Burner Body	<b>23</b>	Nozzle
<b>2</b>	Flame Tube Connection Flange	<b>24</b>	Control Box-1
<b>3</b>	Seal Flange-1	<b>25</b>	Relay
<b>4</b>	Flame Tube	<b>26</b>	Control Box Cover-1
<b>5</b>	Burner Flange	<b>27</b>	Burner Control Relay
<b>6</b>	Seal Flange-2	<b>28</b>	Transformer
<b>7</b>	Fan	<b>29</b>	Control Box-2
<b>8</b>	Fan Motor	<b>30</b>	Limit Switch
<b>9</b>	Fuel Pump	<b>31</b>	Temperature Regulator
<b>10</b>	Shaft	<b>32</b>	Overheat Thermostat
<b>11</b>	Shaft Centering Plate	<b>33</b>	Control Box Cover-2
<b>12</b>	Sight Glass	<b>34</b>	Fuel Suction Pipe
<b>13</b>	Air Klappe	<b>35</b>	Float
<b>14</b>	Air Scale	<b>36</b>	Heating Element
<b>15</b>	Purger	<b>37</b>	Sensor Holder
<b>16</b>	Fuel Seloneid Valve	<b>38</b>	Fuel Tank
<b>17</b>	Air Regulator	<b>39</b>	Overflow Switch
<b>18</b>	Air Seloneid Valve	<b>40</b>	Overflow Tank
<b>19</b>	Air Distributor and Manometer	<b>41</b>	Photocell
<b>20</b>	Nozzle Adaptor	<b>42</b>	Tank Cover
<b>21</b>	Flame Ring	<b>43</b>	Air Safety Valve
<b>22</b>	Ignition Electrode		

ECO WO-70/100

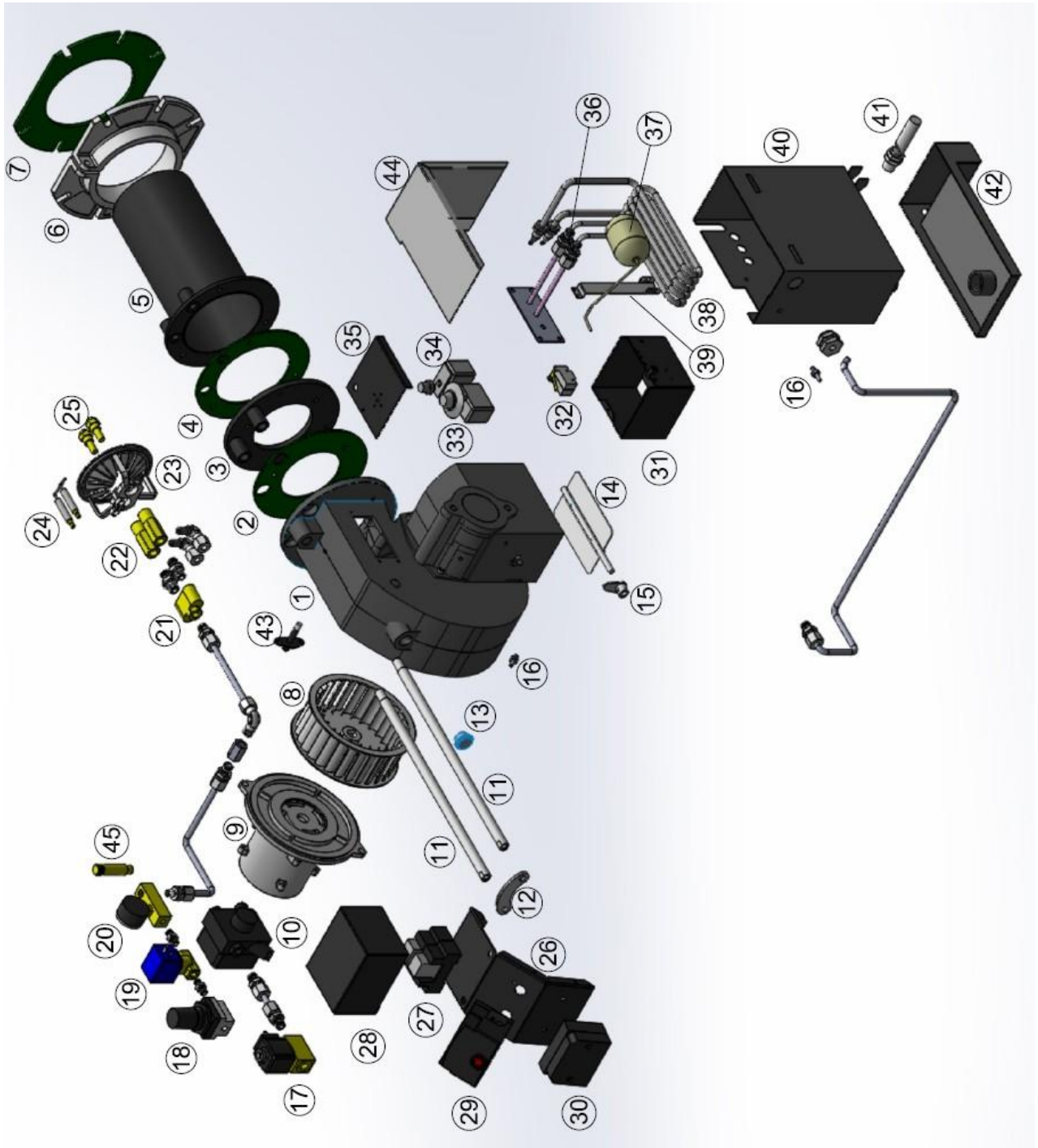

ECO WO-150/200

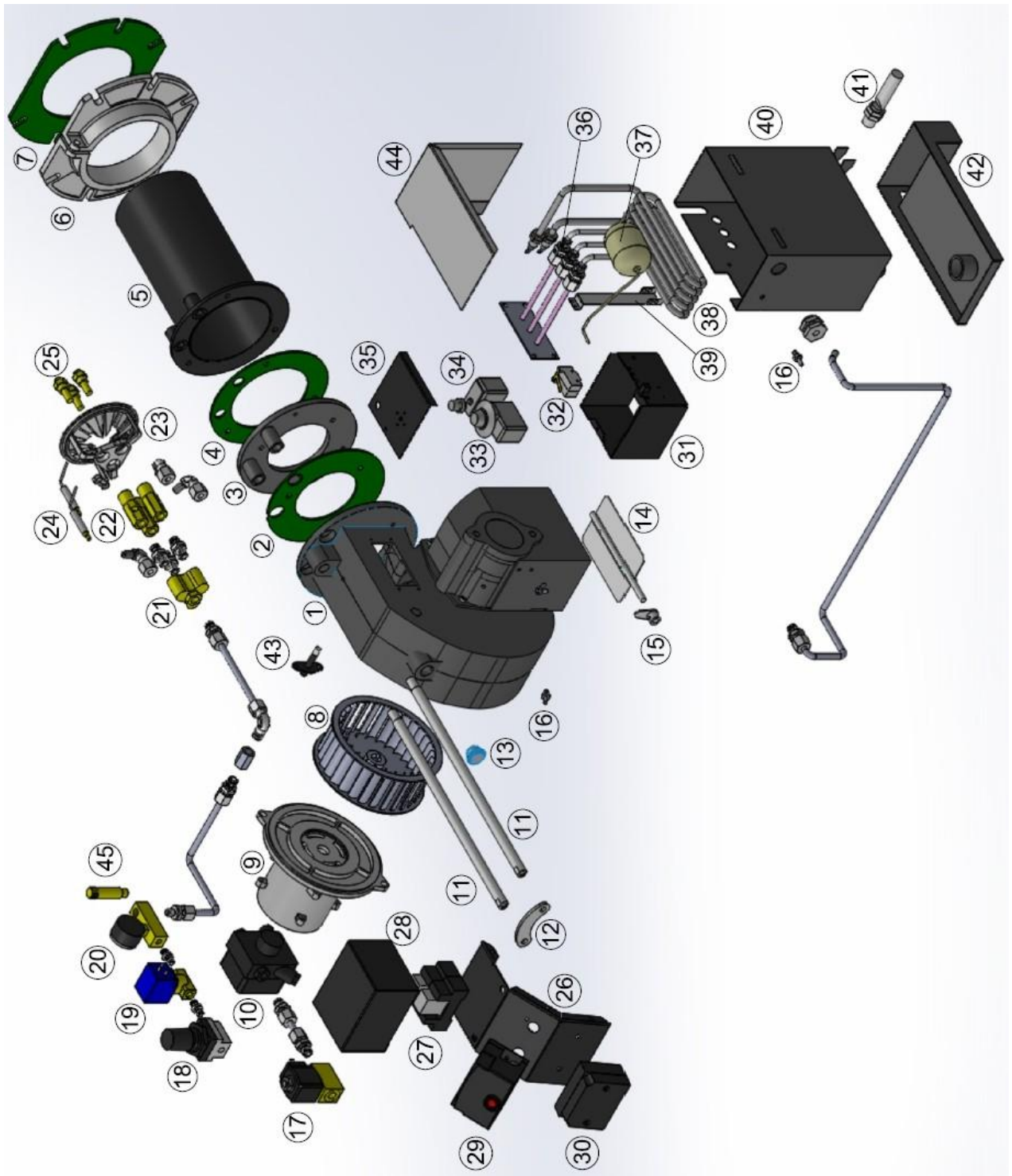

<b>ECO WO-70/100/150/200</b>			
<b>No</b>	<b>Name</b>	<b>No</b>	<b>Name</b>
<b>1</b>	Burner Body	<b>24</b>	Ignition Electrode
<b>2</b>	Seal Flange-1	<b>25</b>	Nozzle
<b>3</b>	Flame Tube Connection Flange	<b>26</b>	Control Box-1
<b>4</b>	Seal Flange-2	<b>27</b>	Relay
<b>5</b>	Flame Tube	<b>28</b>	Control Box Cover-1
<b>6</b>	Burner Flange	<b>29</b>	Burner Control Relay
<b>7</b>	Seal Flange-2	<b>30</b>	Transformer
<b>8</b>	Fan	<b>31</b>	Control Box-2
<b>9</b>	Fan Motor	<b>32</b>	Limit Switch
<b>10</b>	Fuel Pump	<b>33</b>	Temperature Regulator
<b>11</b>	Shaft	<b>34</b>	Overheat Thermostat
<b>12</b>	Shaft Centering Plate	<b>35</b>	Control Box Cover-2
<b>13</b>	Sight Glass	<b>36</b>	Fuel Suction Pipe
<b>14</b>	Air Klappe	<b>37</b>	Float
<b>15</b>	Air Scale	<b>38</b>	Heating Element
<b>16</b>	Purger	<b>39</b>	Sensor Holder
<b>17</b>	Fuel Solenoid Valve	<b>40</b>	Fuel Tank
<b>18</b>	Air Regulator	<b>41</b>	Overflow Switch
<b>19</b>	Air Solenoid Valve	<b>42</b>	Overflow Tank
<b>20</b>	Air Distributor and Manometer	<b>43</b>	Photocell
<b>21</b>	Fuel Distributor (Double/Triple)	<b>44</b>	Tank Cover
<b>22</b>	Nozzle Adaptor	<b>45</b>	Air Safety Valve
<b>23</b>	Flame Ring (Double/Triple)		

#### 4.5. Outer Dimensions

##### ECO WO-20/55

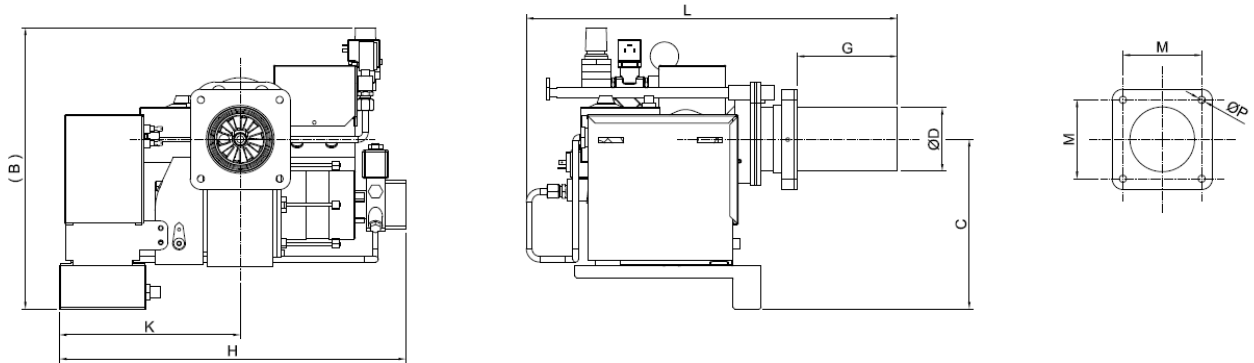

##### ECO WO-70/100/150/200

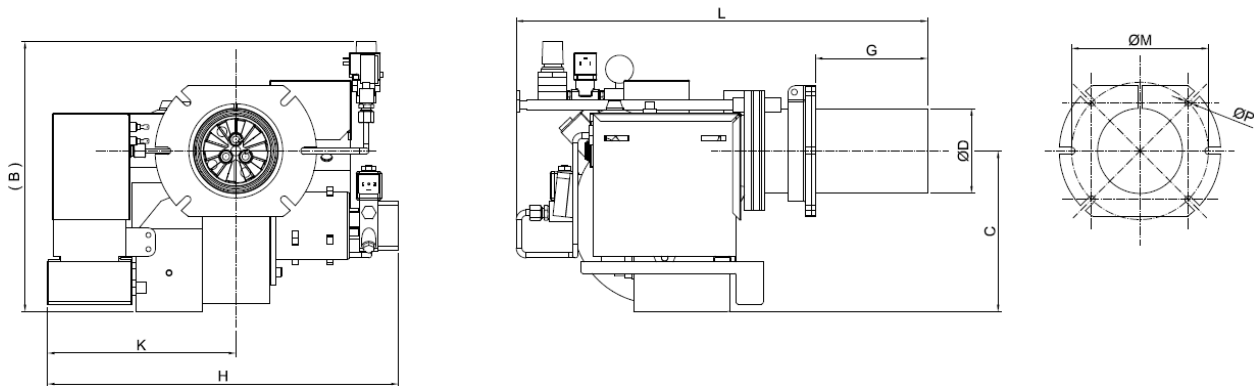

	L	Gmax	H	K	B	C	ØP	M	ØD
<b>ECO WO-20/55</b>	520	140	485	250	400	240	10	110	89
<b>ECO WO-70/100/150/200</b>	590	165	500	270	400	230	10	195	120

#### 4.6. Noise Level

The product runs in min. 75 decibel max. 80 decibel range.

#### 4.7. Basic Settings

When using synthetik oil, mix with min 10 % heating oil for start safety.

When using oil from plants, set oil temperature regulator to 80 - 100°C.

When using heating oil EL set oil temperature regulator to minimum.

Adjustment Thermostat	
Rape Seed Oil	60-140 °C
Multi Oil	60-100 °C
Heating EL/Diesel	0 °C (Not to heat)

#### 4.8. Function Description

The combustible is pumped from the storage tank by **burner pump** into the burner tank.

A **floating switch** regulates the level in the burner tank.

An additional **micro switch** functions as a limit which indicates in case of overfilling.

A **contact switch** stops the burner in case of overflow in the tank.

A **thermostat** regulates the oil temperature in the burner tank and switches on the burner automatically as soon as the regulated temperature is reached.

An additional over heat thermostat prevents overheating with malfunctioning.

Then the **burner control** checks the procedure.

A special nozzle draws the fuel, by using the passing **compressed air**, which serves as primary air for the combustion, and atomizes it.

The **combustion fan** delivers the secondary air that is mixed with the spray mist at the **flame ring**.

The burner is equipped by a security valve. Opening pressure :

**ECO WO-20 to ECO WO-100 - 1,2 bar, ECO WO-150 to ECO WO-200 - 1,5 bar**

Thereby a perfect combustion and safe operating are guaranteed.

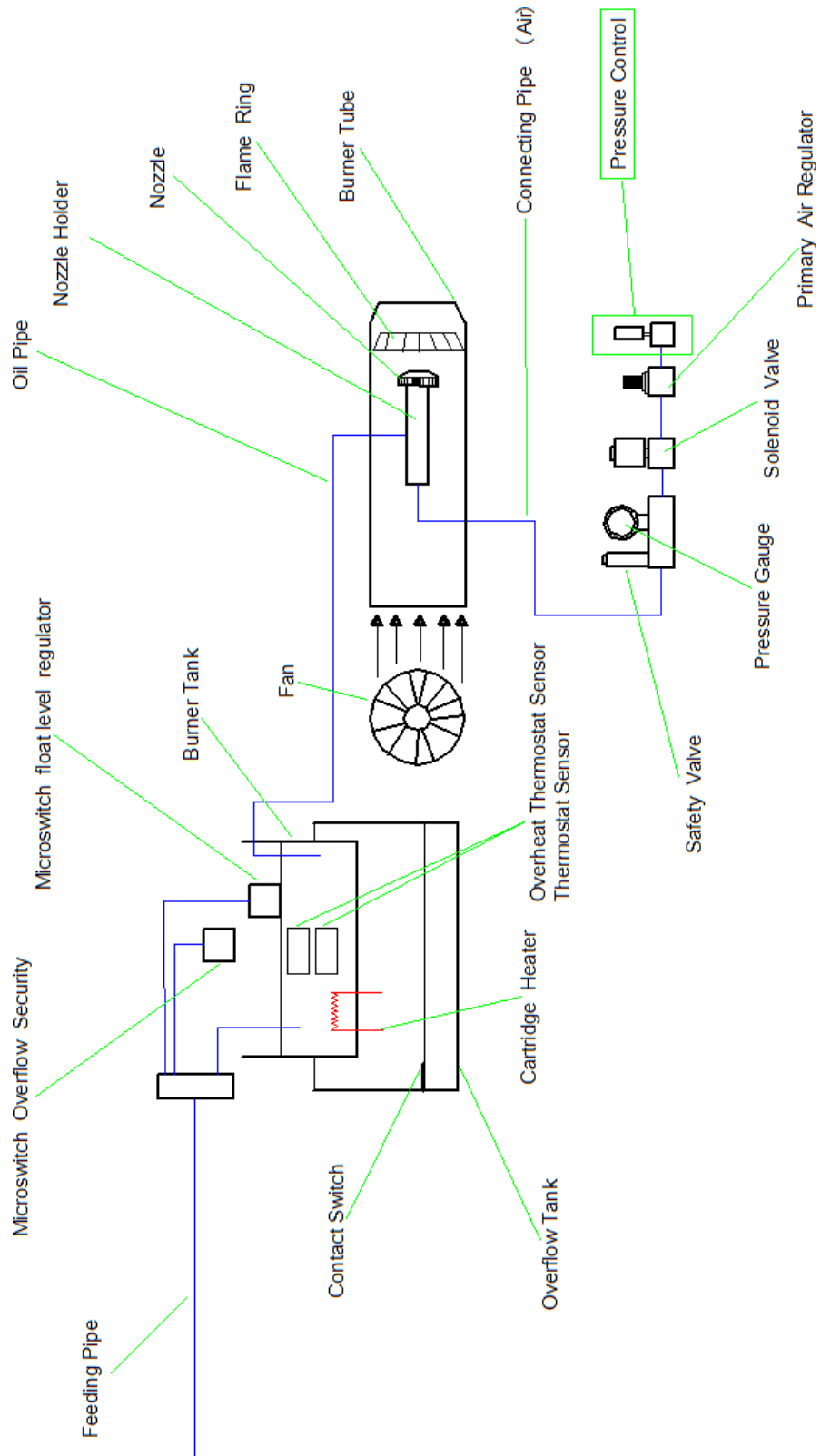



**Burner has to be adjusted only by authorised qualified technicians according to the corresponding regulations.**

## **5. REGULATIONS**

Post regulation of oil consumption by the primary air regulator Post regulation of smoke number and CO<sub>2</sub> by secondary air regulator

### **5.1. Primary air regulator**



**Don't change the position of the pressure regulator after adjustment. Attention to proper locking of the turning knob !**

### **5.2. Secondary air regulator**

**ECO WO-20  
ECO WO-55  
ECO WO-70**

**ECO WO-100  
ECO WO-150  
ECO WO-200**



### **Optimum values:**

smoke number as Bacharach “<1”

CO<sub>2</sub> = 10 to 11,5 Vol. %

Exhaust temperature according to the instruction manual of the heater/fire equipment Δt approx. 200°C

## **6. ATTENTION PLEASE - A SUMMARY OF IMPORTANT POINTS REGARDING “ECO WO”**

1. Read operating instructions carefully, prior to installing and commissioning the heater.
2. The incorrect adjustment of the burner may destroy the combustion chamber and the heat exchanger; therefore, it is important that the output is correctly set. In order to avoid condensation, the net temperature of the flue gases (=the measured temperature of the flue gases in °C minus the inlet temperature of the burner in °C minus the inlet temperature of the burner in °C) must not drop below a value of 160°C (at space heaters).
3. The burner adjustment must be carried out by a specialist (after-sales service for the burner). The flames must on no account touch the walls of the combustion chamber.
4. Clean the combustion chamber and the heat exchanger **at least** once a year. Have the oil burner checked and serviced **at least** annually. Conclude a service contract.
5. Do not switch off at the master switch while heating .
6. Rectify the cause of defect before unlocking the overheat thermostat (warm air thermostat) or the overload relay.
7. In order to qualify for the guarantee, the device must be installed and commissioned by a specialist. The settings are to be recorded in a measurement certificate.
8. Please fill out all the points of the guarantee form correctly, sign, and send it to as ECO WO. Please note that in case of missing measuring values no guarantee certificate will be used.
9. In case of temperatures below 4°C, the oil should be heated in the reservoir (or in the unit tank respectively). (For the relevant heating cartridges, please refer to the accessories).
10. In order to protect the control of the heating please note the charging rate of the burner (if necessary, install an additional relais).

## 7. INSTALLATION & COMMISSIONING

- **ECO WO** waste oil burners contain boiler connection flange and seal.
- Connect the boiler connection flange and the seal to the boiler using 4 bolts.
- Connect the burner to the boiler and tighten the bolts.
- Install oil pipe from the storage tank.
- Connect the connector coupling of a compressed air pipe with the connection nipple of the pressure reducer.



To avoid malfunctions we recommend the mounting of condensation drainage at the ducting between compressor and burner.

- Connect the burner to a power source using the electrical diagram.

### 7.1. Setting Into Operation

1. When setting into operation for the first time, fill up the burner tank by hand to the oil level mark.



When the oil level is too high, the float switch switches off the burner automatically. If the oil level is too low, the cartridge heater will be damaged.



In case of overheating, the overheating thermostat will switch off the burner. After cooling down, reengage the overheating thermostat:

- Unscrew protecting cap,
- Press reset button,
- Fix again the protecting cap.

2. Wait the burner will start automatically as soon as the fuel has reached the right operation temperature.

3. Post regulation of oil consumption by the primary air regulator and post regulation of smoke number and CO by secondary air regulator.



Don't change the position of the primary air pressure regulator after adjustment.

## 7.2. Flame Ring And Ignition Electrode

ECO WO-20/55

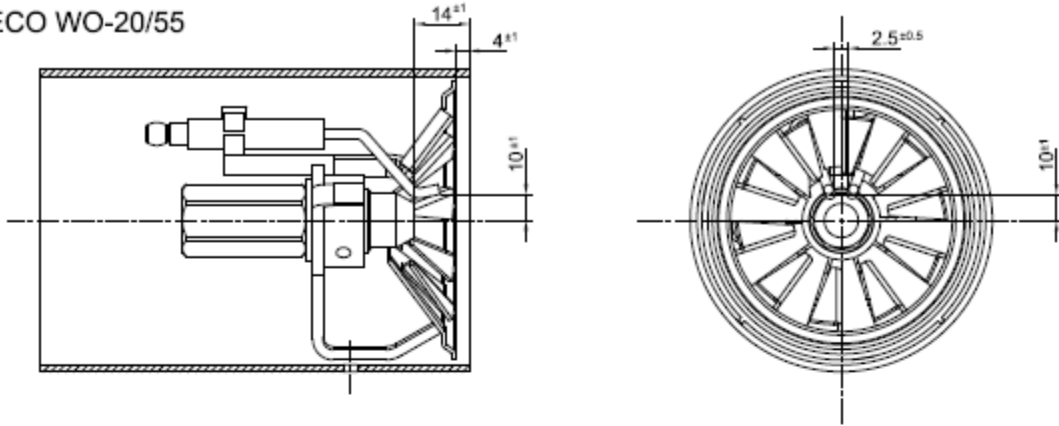

ECO WO-70/100

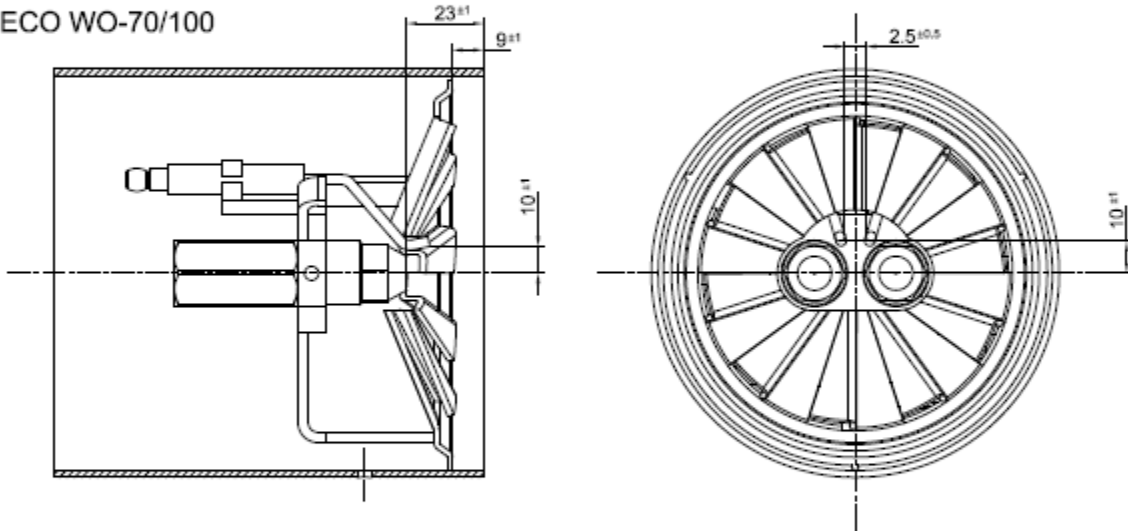

ECO WO-150/200

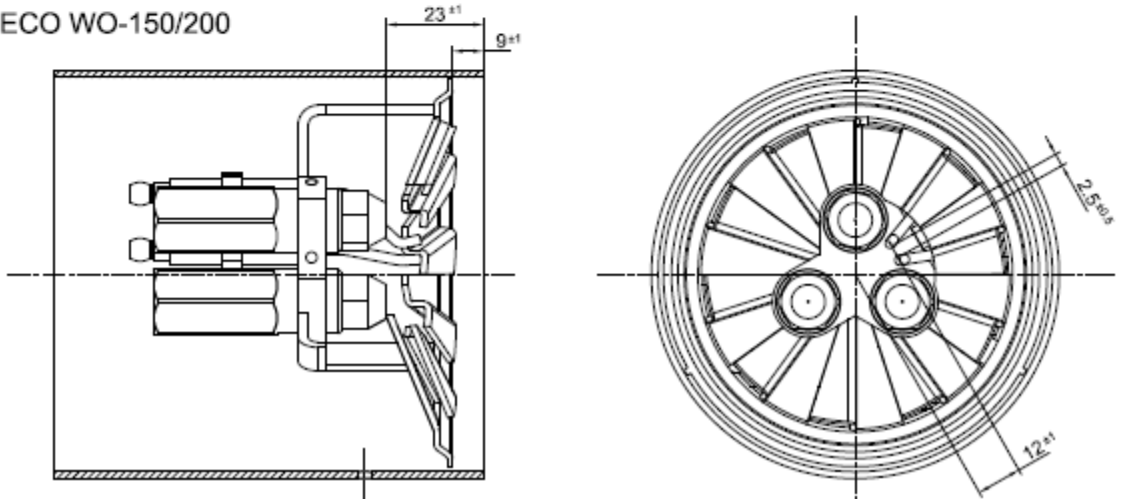

## 8. TROUBLESHOOTING

<b>Problem</b>	<b>Cause</b>	<b>Explanation-Suggestion</b>
<b>Burner does not ignite or Flame interrupts and stops</b>	Heating oil is not combustible due to sludge or water contamination	Open drain tap of burner tank, drain sludge and water or use better heating
	Oil tank empty	Refill with oil
	Oil level in burner tank too high	Correct oil level by draining through drain tap and readjust if necessary, float-switch-level setting
	Oil level in burner tank too low	Correct oil level and refill
	No ignition	Adjust ignition electrode and if replace necessary. Check transformer and ignition leads
	Photo cell dirty or not plugged in correctly	Clean photo cell, replace or plug it in correctly
	Burner control defective	Replace burner control
	No compressed air	Connect compressed air and adjust pressure
	Compressed air too low	Verify the compressed air (not below 2 bar)
<b>No oil supply to the burner tank</b>	Compressor or air pipe defective	Check compressor and air pipe and repair it
	Feeding pump dirty	Clean feeding pump strainer
	Strainer of the floating suction device is clogged	Clean strainer
	Motor capacitor defect	Replace motor capacitor
<b>Nozzle clogged or carbonized</b>	Motor defect	Replace motor
	Flame ring falsely set	Correct measuring of the flame ring
	Too much or too less compressed air	Correct gauge pressure
	To little ventilation in the heating room	Make ventilation openings big enough

## 9. ELECTRICAL DIAGRAM

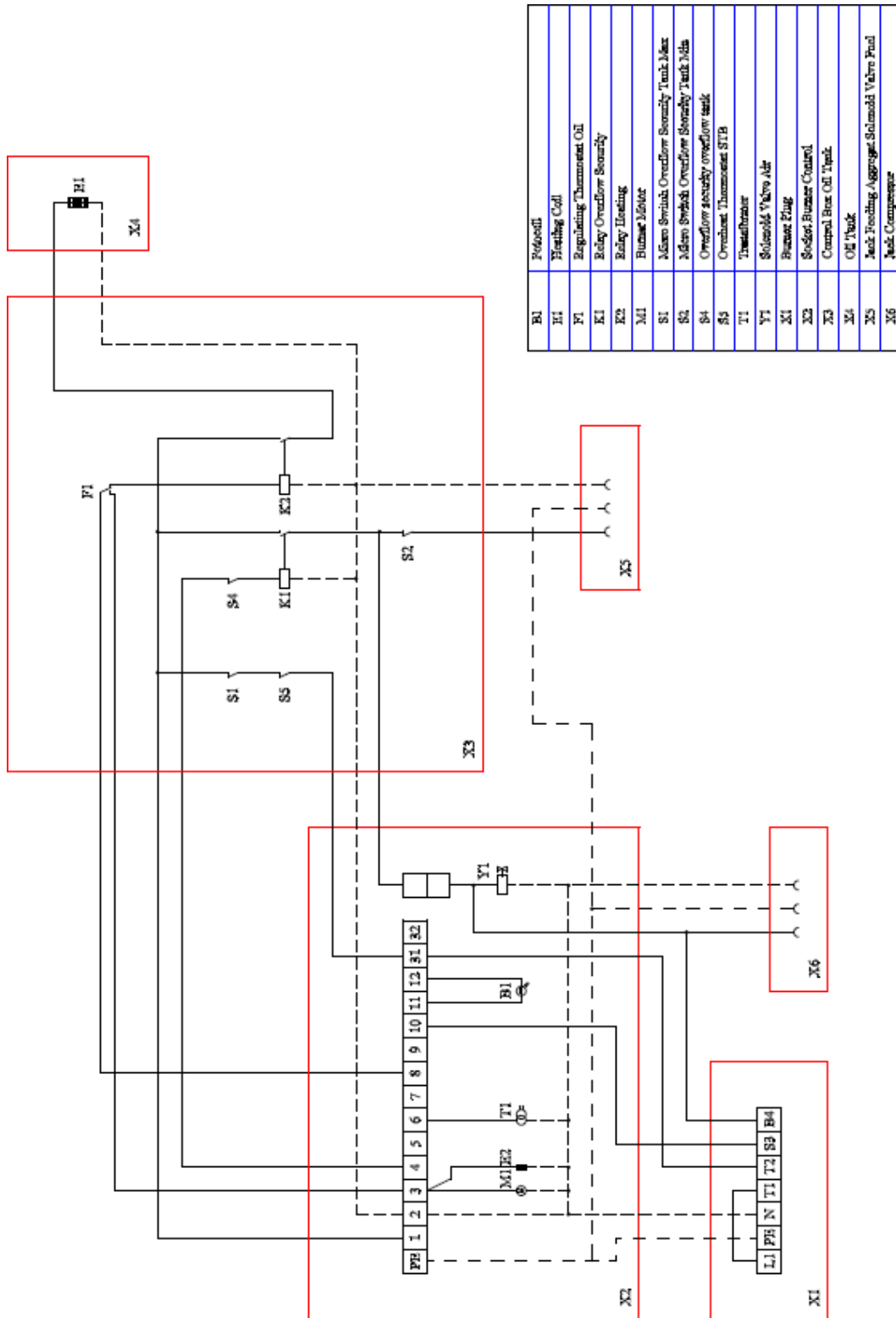



## 11. AFTER SALES SERVICES

Dear Customer,

We believe that providing a good service is as important as providing a good product. Therefore, we continue offering wide range of comprehensive services to our conscious customers.

Our contact details for your requests and complaints

Customer Contact Office

**Çağla Plaza, Atakent, Mithatpaşa Cd. No:116, 34760 Ümraniye/İstanbul**

Factory Contact Details

**Türkgücü OSB Bülent Ecevit Bulvarı No:11**

**ÇORLU/TEKİRDAĞ/TÜRKİYE**

**Tel: +90 282 685 44 80-81**

**Fax: +90 282 685 42 09**

Also you can contact with us:

**Web site : [www.ecostar.com.tr](http://www.ecostar.com.tr) E - mail : [servis@ecostar.com.tr](mailto:servis@ecostar.com.tr)**



Please observe the following recommendations.

- Use the product in accordance with the principles of this manual.
- For any service demands regarding the product, please contact our Service Center from the abovementioned phone numbers.
- Upon your purchase, register your warranty certificate during installation.

